

Razvoj mehatroničkih koncepata za haptičku dojavu sličnih pritisku gumba u kombinaciji s pokaznicima osjetljivima na dodir

Kljajić, Zorica

Master's thesis / Diplomski rad

2017

Degree Grantor / Ustanova koja je dodijelila akademski / stručni stupanj: **University of Zagreb, Faculty of Mechanical Engineering and Naval Architecture / Sveučilište u Zagrebu, Fakultet strojarstva i brodogradnje**

Permanent link / Trajna poveznica: <https://urn.nsk.hr/urn:nbn:hr:235:963271>

Rights / Prava: [In copyright](#) / [Zaštićeno autorskim pravom](#).

Download date / Datum preuzimanja: **2024-12-21**

Repository / Repozitorij:

[Repository of Faculty of Mechanical Engineering and Naval Architecture University of Zagreb](#)



UNIVERSITY OF ZAGREB
FACULTY OF MECHANICAL ENGINEERING AND NAVAL
ARCHITECTURE

In cooperation with EDAG ENGINEERING, Fulda, Germany

MASTER'S THESIS

Zorica Kljajić

Fulda, 2017

UNIVERSITY OF ZAGREB
FACULTY OF MECHANICAL ENGINEERING AND NAVAL
ARCHITECTURE

In cooperation with EDAG ENGINEERING, Fulda, Germany

MASTER'S THESIS

University supervisor:

Prof. dr. sc. Danijel Pavković, dipl. ing.

Company supervisors:

Dipl. ing. Wolfgang Reul

Dipl. ing. Michael Jahn

Student:

Zorica Kljajić

Fulda, 2017

DECLARATION OF AUTHORSHIP

I, Zorica Kljajić, declare that this thesis and the work presented in it are my own and has been generated by me as the result of my own original research.

Development of mechatronic concepts for haptic feedback similar to a button click in combination with touch displays

I confirm that:

1. This work was done wholly while in candidature for a research degree at this University in collaboration with Edag Engineering corporation.
2. Where I have consulted the published work of others, this is always clearly attributed.
3. Where I have quoted from the work of others, the source is always given. With the exception of such quotations, this thesis is entirely my own work.
4. I have acknowledged all main sources of help.
5. Where the thesis is based on work done by myself jointly with others, I have made clear exactly what was done by others and what I have contributed myself.

I would like to thank my university supervisor, Danijel Pavković, for the remarks and detailed corrections, which enabled this thesis to be written in precise English.

Furthermore, I would like to thank my company supervisors, Wolfgang Reul and Michael Jahn, for introducing me to the topic as well as for their engagement and useful comments through the learning process of this master's thesis and prototype design.

In the end, I would like to thank my mother, Marija Kljajić, for supporting me financially during my stay in Germany.

Signed:

Date:



SVEUČILIŠTE U ZAGREBU
FAKULTET STROJARSTVA I BRODOGRADNJE



Središnje povjerenstvo za završne i diplomske ispite
Povjerenstvo za diplomske ispite studija strojarstva za smjerove:
proizvodno inženjerstvo, računalno inženjerstvo, industrijsko inženjerstvo i menadžment, inženjerstvo materijala i mehatronika i robotika

| | |
|-------------------------------------|--------|
| Sveučilište u Zagrebu | |
| Fakultet strojarstva i brodogradnje | |
| Datum | Prilog |
| Klasa: | |
| Ur.broj: | |

DIPLOMSKI ZADATAK

Student: **Zorica Kljajić** Mat. br.: 0035184885

Naslov rada na hrvatskom jeziku: **Razvoj mehatroničkih koncepata za haptičku dojavu sličnih pritisku gumba u kombinaciji s pokaznicima osjetljivima na dodir**

Naslov rada na engleskom jeziku: **Development of mechatronic concepts for haptic feedback similar to a button click in combination with touch displays**

Opis zadatka:

U posljednje vrijeme postoji sve veći trend uvođenja pokaznika osjetljivih na dodir (engl. *touch display*) u cestovna vozila radi povećanja fleksibilnosti sustava za informiranje i zabavu (engl. *infotainment systems*) i poboljšavanja ukupnog komfora vožnje (engl. *riding comfort*). Pritom postojeća rješenja aktuatora i alarmnih sustava u vozilima trebaju zadovoljavati daleko strože standarde u smislu pravovremenog i točnog alarmiranja vozača u odnosu na mobilne uređaje široke namjene. Dodatno, neke standardne funkcionalnosti prisutne kod mehaničkih sustava za unos (tipkovnica) je vrlo teško oponašati korištenjem postojećih aktivnih sustava za dojavu s tzv. haptičkom povratnom spregom (engl. *haptic feedback*) prema korisniku u obliku vibracijske dojave. U radu je potrebno napraviti sljedeće:

1. Odabrati odgovarajući tip aktuatora za vibracijsku dojavu putem prednjeg panela pokaznika, s osvrtnom na njihovu kompaktnost i potrošnju energije.
2. Ispitati mogućnosti mehaničkog spajanja sustava aktuatora na prednji panel, pri čemu treba obratiti pažnju na svojstva materijala i komponenata od kojih će se načiniti mehanička veza, kao na primjer prozirnost, prigušenje vibracija, izdržljivost i jednostavnost sklapanja.
3. Odabrati odgovarajuću frekvenciju i amplitudu pobude aktuatora kako bi se gibanjem prednjeg panela čim vjernije oponašalo ponašanje sklopke, odnosno tipke na tipkovnici.
4. Razmotriti alternativne scenarije dojave uključujući alternativu oponašanju pritiska tipke.
5. Izraditi postav za ispitivanje i demonstraciju funkcionalnosti pojedinih koncepata aktuatora, uključivo sa razvojem programske podrške za upravljanje aktuatorom s ciljem emulacije različitih modela dinamičkog vladanja prednjeg panela.
6. Temeljem dobivenih rezultata treba validirati predložene koncepte aktuatora eksperimentalnim putem i predložiti najizglednija rješenja, odnosno definirati buduće pravce razvoja haptičkih aktuatora.

Zadatak zadan:
19. siječnja 2017.

Rok predaje rada:
23. ožujka 2017.

Predviđeni datum obrane:
29., 30. i 31. ožujka 2017.

Zadatak zadao:

Prof. dr. sc. Danijel Pavković

Predsjednica Povjerenstva:

Prof. dr. sc. Biserka Rurje

TABLE OF CONTENTS

| | |
|---|------|
| TABLE OF CONTENTS | I |
| LIST OF FIGURES | IV |
| LIST OF TABLES | VI |
| TECHNICAL DOCUMENTATION | VII |
| LIST OF ABBREVIATIONS | VIII |
| SUMMARY | X |
| ZUSAMMENFASSUNG | XI |
| 1. INTRODUCTION | 1 |
| 1.1. Company Edag Engineering GmbH | 1 |
| 1.1.1. Idea for the Thesis | 1 |
| 1.2. Motivation | 2 |
| 1.3. Issues and research problems | 3 |
| 1.4. Goal of this work | 4 |
| 2. BASICS..... | 6 |
| 2.1. Human-Machine-Interface..... | 6 |
| 2.2. Human senses and perception..... | 7 |
| 2.3. Haptic technology..... | 12 |
| 2.3.1. Principles..... | 12 |
| 2.4. Types of haptic feedback scenarios | 14 |
| 3. METHODS FOR PRODUCING HAPTIC FEEDBACK..... | 16 |
| 3.1. Inertial actuation | 18 |
| 3.1.1. ERM – Eccentric Rotating Mass | 19 |
| 3.1.2. LRA – Linear Resonant Actuator..... | 20 |
| 3.2. Piezoelectric Actuation..... | 23 |
| 3.2.1. Types of piezoelectric actuators | 26 |
| 3.3. Voice coil and Solenoid Actuators | 30 |
| 3.4. Electroactive-Polymer-Actuation (EAP)..... | 32 |
| 3.5. Surface Actuation | 33 |
| 3.6. Capacitive Electrosensory Interface (CEI)..... | 34 |
| 4. IDENTIFICATION OF REQUIREMENTS..... | 36 |

| | | |
|--------|--|----|
| 4.1. | Demand analysis | 36 |
| 4.1.1. | Intensity | 38 |
| 4.1.2. | Bandwidth | 38 |
| 4.1.3. | Power consumption | 39 |
| 4.1.4. | Response time | 39 |
| 4.1.5. | Mounting | 40 |
| 4.1.6. | Drive voltage | 40 |
| 4.1.7. | Audible noise..... | 40 |
| 4.2. | Selection of the actuator | 40 |
| 4.3. | Kyocera Piezoelectric actuator | 42 |
| 5. | METHODICAL CONCEPT DEVELOPMENT | 45 |
| 5.1. | Requirements | 45 |
| 5.2. | Concept synthesis | 49 |
| 5.2.1. | Concept I – Piezo between display unit and front plate..... | 50 |
| 5.2.2. | Concept II – Piezo on holder laterally..... | 54 |
| 5.2.3. | Concept III – Piezo inside the holder | 57 |
| 5.2.4. | Concept IV – Piezo element separated from the adhesive | 59 |
| 5.3. | Evaluation criteria..... | 59 |
| 5.4. | Concept selection..... | 60 |
| 5.4.1. | Generation of selection tables | 61 |
| 5.4.2. | Final concept selection | 64 |
| 5.4.3. | Kyocera support equipment | 67 |
| 6. | CONCEPT ELABORATION | 69 |
| 6.1. | Concept V – Prototype based on Kyocera’s backlight | 69 |
| 6.2. | Demonstrator design..... | 71 |
| 6.2.1. | Test of applicability..... | 77 |
| 6.3. | Optimization possibilities | 80 |
| 6.3.1. | Foam Tape..... | 81 |
| 6.3.2. | Simple PVC film | 81 |
| 6.3.3. | Rubber hose..... | 82 |
| 6.3.4. | Labyrinth seal | 84 |
| 6.3.5. | Spring steel..... | 87 |
| 6.3.6. | Actuators attached on the backlight’s long sides | 89 |

| | |
|---------------------------------------|-----|
| 6.4. Usability testing | 91 |
| 7. CONCLUSION | 96 |
| 7.1. Verification of the device | 96 |
| 7.2. Summary..... | 98 |
| 7.3. Discussion and Outlook..... | 100 |
| REFERENCES | 102 |
| APPENDIX | 106 |

LIST OF FIGURES

| | |
|---|----|
| Figure 1. Edag Soulmate Exterior | 2 |
| Figure 2. Edag Soulmate Interior | 2 |
| Figure 3. Biological circle of human reception of a haptic event [Source: Kyocera] | 5 |
| Figure 4. Structure of a Human-Machine-Interface [9] | 6 |
| Figure 5. Classification of haptic rendering evaluation techniques and their | 7 |
| Figure 6. Schematic drawing of the eye [14] | 8 |
| Figure 7. Haptics Ecosystem | 13 |
| Figure 8. Different vibration profiles for haptic effects [Source: Precision Microdrives] | 14 |
| Figure 9. Haptic technologies [20] | 15 |
| Figure 10. Spectrum of haptic feedback [Source: Immersion Corp.] | 16 |
| Figure 11. Approaches to realize a surface vibration [22] | 18 |
| Figure 12. ERM actuators [Source: Precision Microdrives] | 19 |
| Figure 13. Structure of ERM [Source: Precision Microdrives] | 20 |
| Figure 14. LRA actuator [Source: Precision Microdrives] | 21 |
| Figure 15. Structure of LRA [Source: Precision Microdrives] | 21 |
| Figure 16. Typical LRA Response [30] | 22 |
| Figure 17. Vibration directins depending on form factors [Source: Precision Microdrives] | 23 |
| Figure 18. Crystal structure of quartz in initial state and under pressure 40 | 23 |
| Figure 19. Decision tree for the selection of a piezoelectric actuator type [32] | 24 |
| Figure 20. Forms of piezoelectric actuators | 25 |
| Figure 21. Response time of a piezo actuator and a button [Source: Texas Instruments] | 26 |
| Figure 22. Types of Piezoelectric Actuators: a) SL, b) ML [Source: Texas Instruments] | 27 |
| Figure 23. Response time [Source: Texas Instruments] | 29 |
| Figure 24. Power consumption [Source: Texas Instruments] | 29 |
| Figure 25. Actuator mounted on the surface of the touch panel [33] | 31 |
| Figure 26. An example of solenoid actuator [33] | 31 |
| Figure 27. Tactile feedback with both a piezo actuator and solenoid [34] | 31 |
| Figure 28. Lateral movement of the surface [Source: Immersion Corp.] | 32 |
| Figure 29. Reflex HIC Slide Actuator [Source: Artificial Muscle] | 33 |
| Figure 30. Principle of Surface Actuation [Source: Next System] | 34 |
| Figure 31. The mechanism of electrovibration [38] | 35 |
| Figure 32. Principle design of an HMI based on piezoelectric actuators [30] | 43 |
| Figure 33. CAD model of the Kyocera Piezoelectric actuator | 43 |
| Figure 34. Poron Urethane Foam [Source: Stockwell Elastomerics] | 46 |
| Figure 35. Optical Bonding Material [Source: DELO] | 47 |
| Figure 36. Parallax issue [47] | 49 |
| Figure 37. LCD structure [Source: LG] | 50 |
| Figure 38. Concept I – First option of the holder | 51 |
| Figure 39. Concept I - Option A | 52 |
| Figure 40. Concept I - Option B | 52 |
| Figure 41. Concept I - Option C | 53 |

| | |
|--|----|
| Figure 42. Concept I – Option D | 53 |
| Figure 43. Concept II - Option A | 54 |
| Figure 44. Concept II - Option B | 55 |
| Figure 45. Concept II – Option C..... | 56 |
| Figure 46. Concept III - Option A..... | 57 |
| Figure 47. Concept III - Option B | 58 |
| Figure 48. Concept III - Option C | 59 |
| Figure 49. Concept IV | 59 |
| Figure 50. CAD model - final holder | 69 |
| Figure 51. Entire prototype in CAD..... | 70 |
| Figure 52. 3M OCA 8416-x | 71 |
| Figure 53. CAD model of bonded glass plates..... | 72 |
| Figure 54. CAD model holder with backlight..... | 73 |
| Figure 55. CAD model of the actuator's position..... | 73 |
| Figure 56. CAD model of adhesive tape pieces on the holder | 74 |
| Figure 57. CAD model of the supporting material..... | 74 |
| Figure 58. Haptivity software..... | 76 |
| Figure 59. Felt | 77 |
| Figure 60. Objective assessment - tapes in the center | 78 |
| Figure 61. Objective assessment - tapes in the four corners + supporters | 79 |
| Figure 62. Objective assessment - tapes in the four corners without supporters | 79 |
| Figure 63. Tesa62932 double-sided foam tape | 81 |
| Figure 64. Oracal PVC film | 82 |
| Figure 65. Objective assessment - use of PVC film forming lips | 82 |
| Figure 66. Thin rubber hose | 83 |
| Figure 67. Feedback with rubber hose – single sided glued | 83 |
| Figure 68. Feedback with rubber hose - double sided glued..... | 84 |
| Figure 69. Possible labyrinth sealing element..... | 85 |
| Figure 70. Section view..... | 85 |
| Figure 71. Prototype example with a labyrinth sealing..... | 85 |
| Figure 72. Feedback with foam tape and labyrinth sealing..... | 86 |
| Figure 73. Spring steel | 87 |
| Figure 74. CAD model of the Z-shaped spring | 87 |
| Figure 75. CAD model of the U-shaped spring | 88 |
| Figure 76. L-profile holder..... | 89 |
| Figure 77. Prototype with L-profile holder | 89 |
| Figure 78. Objective assessment - actuators on the long sides | 90 |
| Figure 79. Final demonstrator | 92 |

LIST OF TABLES

| | |
|---|----|
| Table 1. Comparison of the body's sensors [12] | 7 |
| Table 2. Output capabilities of human hand [10]..... | 9 |
| Table 3. Definition of haptic feedback technology [Source: Next System]..... | 10 |
| Table 4. Different types of buttons [Source: Next System] | 10 |
| Table 5. Methods for producing haptic feedback..... | 17 |
| Table 6. Comparison of piezo disks and strips [Source: Texas Instruments] | 25 |
| Table 7. Actuator technology [Source: Texas Instruments]..... | 28 |
| Table 8. Energy Consumption Comparison Data [Source: Texas Instruments] | 30 |
| Table 9. First evaluation of possible actuation methods | 37 |
| Table 10. Comparison of three selected methods | 38 |
| Table 11. Intensity..... | 38 |
| Table 12. Bandwidth | 39 |
| Table 13. Power consumption..... | 39 |
| Table 14. Mounting | 40 |
| Table 15. Rating scale VDI 2225 | 41 |
| Table 16. Priority table..... | 41 |
| Table 17. Selection of the actuator | 42 |
| Table 18. Requirements on the prototype design | 45 |
| Table 19. Concept I – selection | 61 |
| Table 20. Concept IV - selection..... | 64 |
| Table 21. Feedback results with 0.1 mm thin spring steel | 89 |
| Table 22. Haptivity button-click feedback | 93 |
| Table 23. Requirements specification verification..... | 97 |

TECHNICAL DOCUMENTATION

- 1 Holder for Piezo actuator
- 2 Labyrinth sealing
- 3 Lateral holder

LIST OF ABBREVIATIONS

| | |
|---------|---------------------------------------|
| HMI | Human-Machine-Interface |
| CUI | Computer-User-Interface |
| HD | High Definition (haptics) |
| ERM | Eccentric Rotating Mass |
| LRA | Linear Resonant Actuator |
| DC | Direct Current Motor |
| OEM | Original Equipment Manufacturer |
| SL | Single-Layer (Piezoelectric Actuator) |
| ML | Multi-Layer (Piezoelectric Actuator) |
| CEI | Capacitive Electrosensory Interface |
| E-sense | Electro Sensory |
| EAP | Electroactive Polymer |
| PWM | Pulse-Width-Modulated (signal) |
| PDA | Personal Digital Assistant |
| CAD | Computer Aided Design |
| CAE | Computer Aided Engineering |
| GUI | Graphical User Interface |
| LCD | Liquid-Crystal Display |
| LED | Light-emitting diode |
| OCA | Optical clear adhesive |
| LOCA | Liquid optical clear adhesive |
| PMMA | Poly (methyl methacrylate) |
| ITO | Indium tin oxide |
| CEF | Contrast enhancement film |
| RGB | Red green blue |

| | |
|-----|--------------------------------|
| PST | Pressure sensitive tape |
| PUR | Polyurethane |
| IP | International Protection Class |
| R&D | Research and development |

SUMMARY

The purpose of this study is the introduction of haptic feedback scenarios for Human-Machine-Interface (HMI) devices and concept development of actuator connections for achieving specific feedbacks similar to pushing a button icon commonly used on touch displays. The proposed design shows how haptics can restore tactile feedback to touch screens and improve the user interaction with machines. It is shown that haptic technology can reduce driver distraction and increase confidence within the vehicle by adding clear and fast response from touch elements in their infotainment center console.

In particular, display and control elements in the automotive and consumer goods industry are getting more flexible in form of touch screens or simple sensor surfaces. Especially new interior concepts of vehicles are changing from multiple physical buttons to displays. This brings a huge disadvantage – the lack of feedback when actuating. The following chapters explain the basics of haptic technology and different types of feedback scenarios including alternatives to a click. Mostly used actuators will be represented with their advantages as well as disadvantages. Further, the main requirements and evaluation criteria will be stressed for choosing the most suitable actuator and the appropriate technical connecting concepts for possible implementations for a touch screen haptics solution. Using actuators which have short rising time is a key point when simulating realistic button click feedback.

Taking the results into account a prototype was implemented. Some of the requirements included the position of the actuator, the display separation into critical components, necessary sealing elements and mounting options of the cover plate. A holder for the actuator was designed and the feedback was tested.

Key words: human-machine-interface, haptics, display, touch screen, actuator

ZUSAMMENFASSUNG

Ziel dieser Arbeit ist die Einführung haptischer Rückmeldungen bei Geräten mit Mensch-Maschine-Schnittstellen (MMS) und Konzeptentwicklung von Aktuator-Anschlüssen, um spezifische Rückmeldungen ähnlich dem Drücken eines Knopfes, der sich üblicherweise auf berührungsempfindlichen Anzeigen befindet, zu erzeugen. Das vorgesehene Design zeigt, wie Haptik taktile Rückmeldungen auf berührungsempfindlichen Oberflächen wiederherstellen und die Interaktion des Benutzers mit Maschinen verbessern kann. Es wird gezeigt, dass haptische Technologie die Ablenkung des Fahrers verringern und das Vertrauen in das Fahrzeug erhöhen kann, indem klare und schnelle Reaktionen der Berührungselemente in die Infotainment-Konsole hinzugefügt werden.

Insbesondere werden Anzeige- und Bedienelemente in der Automobil- und Konsumgüterindustrie in Form von Touchscreens oder einfachen Sensoroberflächen immer mehr flexibel. Innenraumkonzepte mit mehreren physikalischen Tasten verwandeln sich in Konzepte mit Displays. Das bringt einen großen Nachteil mit sich – die fehlende Rückmeldung bei Bestätigung. Die folgenden Kapitel erläutern die Grundlagen der haptischen Technologie und verschiedene Arten von Feedback-Szenarien, einschließlich Alternativen zu einem Klick. Meist verwendete Aktuatoren werden mit ihren Vor- und Nachteilen dargestellt. Weiterhin werden die wichtigsten Anforderungen und Bewertungskriterien für die Auswahl des am besten geeigneten Aktuators und die entsprechenden technischen Anbindungskonzepte für eine mögliche Implementierung in einen haptischen Touchscreen betont. Die Verwendung von Aktuatoren, die eine kurze Anstiegszeit haben, ist ein wichtiger Punkt bei der Simulation von realistischen Knopf-Rückmeldungen.

Unter Berücksichtigung der Ergebnisse wurde ein Prototyp entwickelt. Zu den Anforderungen gehörten unter anderem die Position des Aktuators, die Trennung des Displays in die wichtigsten Komponenten, notwendige Dichtungselemente und Befestigungsmöglichkeiten der vorderen Glasscheibe. Eine Halterung für den Aktuator wurde konstruiert und die Rückmeldung erprobt.

Schlüsselworte: Mensch-Maschine-Schnittstelle, Haptik, Bildschirmanzeige, Aktuator, berührungsempfindliche Oberfläche

1. INTRODUCTION

1.1. Company Edag Engineering GmbH

This thesis has been written in the German company Edag¹ in Fulda, in the state of Hesse, in duration of six months. The company works in the field of product development and is one of the world's largest independent development partners in the automotive industry. They deliver innovative solutions and new technologies, trying to predict trends and changes in modern vehicles. The company participates in the development of a complete vehicle with all parts, from idea creations and concept developments to prototyping, 3D printing and small batch production. Some of their customers are Audi, BMW, Bosch, Bugatti, Daimler, Electrolux, Fiat, Ford, GM, Honda, Hyundai, Opel, Porsche, Siemens, Thyssen Krupp, Miele, and many others.

The company has more than 8 thousand employees in 25 countries. There is no branch office in Croatia yet, but the closest offices are in Hungary and Czech Republic. The project contributions for Original Equipment Manufacturers (OEMs) are 63%, automotive suppliers 33% and 4% for traffic and transport. The development is split into the main categories:

- Design and concept development
- Vehicle design
- Vehicle functions
- Testing CAE²
- Electronics

The entire research and writing part of this master's thesis has been carried out in the company's sub department Package & Concepts.

1.1.1. Idea for the Thesis

Edag developed 16 of their own concept cars. For example, the Edag “*Soulmate*” represents a view of cars of the future which are increasingly being built with the aim of weight reduction [1]. The company worked on this project together with Bosch GmbH in order to show in which way the connection between the driver and vehicle has changed. The composition of the external structure is made up of a bionically inspired skeleton structure covered with a fabric-based outer skin. This outer skin enables the Edag developers to illuminate the interior and exterior surfaces. The vehicle can also communicate with the driver, as well as with the outside world. The luminous outer skin can alert other road users to a possible danger, traffic jam etc. On the other hand, if a bicyclist or other vehicle is in the vehicle's blind spot, *Soulmate* illuminates the interior of the relevant door so that it flashes in red to warn the driver.

¹ <http://www.edag.de/en/edag.html>

² Computer Aided Engineering



Figure 1. Edag Soulmate Exterior

Owing to the Bosch system, the driver is in constant contact with his smart home over his smartphone. If a deliveryman comes to the door, the driver simply touches the display in the car to let him into a protected area of the house. The infotainment system is controlled by means of displays using haptic feedback and gestures. For this purpose, the haptic display “*neoSense*” system is installed – which comprises a touch screen that gives the driver the feeling that he/she is using mechanical buttons. This device can even generate different surface textures, which means that tactile sensation is also implemented on the display.

Soulmate is maybe an evolutionary step for the vehicles which finally brings together riding comfort and the comfort of the digital everyday life to perfection. At this point, the idea for a Master’s Thesis came to mind. How exactly did Bosch develop their haptic touch screen *neoSense* remains confidential, similar to haptic technologies of other companies like Continental, Apple or Immersion³. Naturally, Edag would like to possess its own solution which might be offered to future clients.



Figure 2. Edag Soulmate Interior

1.2. Motivation

One of the great changes in automotive dashboard design over the last years has been the introduction of displays. More recently, these displays have become touch-screens. As with most touch screen interfaces, haptic feedback has been introduced to provide the user with tactile information equivalent to pressing a physical button. Adding haptic feedback has many advantages for manufacturers [2]. It improves the user experience and the performance of operation. It reduces the number of mechanical buttons, thus offering the designer much greater freedom over form and design.

³ <https://www.immersion.com/>

Namely, even everyday consumer products are being increasingly developed with touch displays and corresponding interfaces. In this sense, the traditionally more common control panels with buttons and switches are becoming increasingly expensive, while the designers nowadays can make specific user interfaces by simply changing the graphical layout on screens. Using vibrations to transfer information through the control system/interface allows users to focus on the task at hand. For example, typing on a virtual keyboard, a short “button press” effect provides the user with information whether the keystroke has been recognized. Vibration alerting is easier to implement compared to haptics because the system has no need to provide details to the user, it just needs to ensure that an event has occurred [2]. For this reason, the main consideration is the amplitude and power consumption. Vibration actuator's “rise and lag” times are not as important as in case of haptic feedback systems. Tactile feedback and vibration alerting use similar actuators to produce the sense of touch. The challenge lies in more complex implementation of haptic feedback. It is still a new field of study, and consequently many aspects have not been explored yet.

Haptics is used to give unique information to automotive users. Automotive OEMs firstly began to use smaller LCD⁴ displays for radio or climate controls without touch interaction. Nowadays, the center console has increased display sizes with more room for user interaction. Eight-inch⁵ displays are common in automobiles today[3]. Current applications of touch screens are naturally focused on sight and sound alerts because they are easy to implement. However, several studies have shown haptic feedback can facilitate much more satisfying results. The challenge lies in the increasing amount of information that interfaces have to provide to the driver and passengers

1.3. Issues and research problems

Driver distraction has become a huge issue considering all the new technologies which are increasingly being introduced into the cabin of today's automobiles [4]. Therefore, tactile and haptic feedback is becoming increasingly important in the automotive sector because drivers cannot look at displays to be sure if a button has been pressed and focus on the road at the same time. One of the problems comes from the infotainment center console. Since there is no tactile feedback when the driver is navigating through different settings, he/she needs to take his/her eyes off the road to see whether the required input was accepted. On the other hand, when a user types for example on a computer keyboard, he feels a click or bump when pressing the key [5]. Most manufacturers place a large importance on creating safe and innovative ways to keep the driver's focus on the road. Due to these reasons, the user interface within a state-of-the-art vehicle must be intuitive, easy to use and offer rich features, but should also simultaneously maintain safety standards and minimize distraction at the same time. Applying haptics and movement of a touch surface is a challenging procedure, so the haptic design considerations have to be covered during the initial stages of the vehicle-interior design [3].

⁴Liquid-Crystal Display

⁵ 1 in (inch) = 25,4 mm

Nowadays, brilliant displays are expected by default which represents a challenge for the designers. The loss of the tactile feedback which users usually get from conventional mechanical input mechanisms, leads to higher error rates and in some cases, even to frustration [6]. One way to fix the problem that many manufacturers are having with the capacitive touch elements is adding additional equipment with tactile feedback to their devices. These technologies are advancing, but success lies in the importance it brings to the automotive user experience.

While evaluating haptic implementations, one of the key tasks is to estimate the risk and cost of adding these features. What might be the costs and design challenges for adding additional hardware and software and will the users eventually see value in this feature? Adding movement to touch interfaces requires new re-designs. Maybe some combination of light and sound feedbacks could be enough to satisfy the driver? Research points out that consumers prefer tactile feedback over other possibilities once they are aware of the possibility [3]. Even though mechanical buttons functioned well, automotive manufacturers want to replace them because they are more aware of the benefits of integrating the latest electronics technologies into their vehicles. Today's drivers want to interact with their vehicles the same way they do with their electronic devices.

1.4. Goal of this work

Today's products are scheduled to communicate with their users [2]. Until recently these devices have used audible and visual alerts, such as LEDs⁶, beeps or bells. Haptic feedback, which is often called "vibration alerting", is in increasing demand to expand or replace the more mature alert methods. Haptic feedback and vibration alerting are indeed very similar. However, the main difference is that haptic feedback devices use a range of different waveforms to forward information to the user, while vibration alerting is a less sophisticated process. While the visual and auditory feedback are still effective in many applications, there are many others where the functionality of the product can be advanced by replacing or combining the sense of hearing and sight with the sense of touch.

Most experiments involving the perception of haptic feedback are made with unique prototypes of standard touch screens upgraded with external actuators. That is why there are no rules about what exactly specific haptic event should „feel like“ exist. This work will give a description of different kinds of feedback approaches with the focus on the „button click“ effect. The following chapters deal with possibilities and principal limits of human touch sense as well as the theoretical nature of touchscreen interactions.

The aim of this thesis is to define necessary evaluation criteria for product development in the field of haptic feedback solutions. Based on this evaluation, a specific approach to haptic feedback solution can be defined in order to decide which technology (technologies) might be used for the implementation of a haptic touch screen. Additionally, on the basis of the possible approach the practical implementation can be demonstrated by building a prototype.

⁶ Light-emitting diode

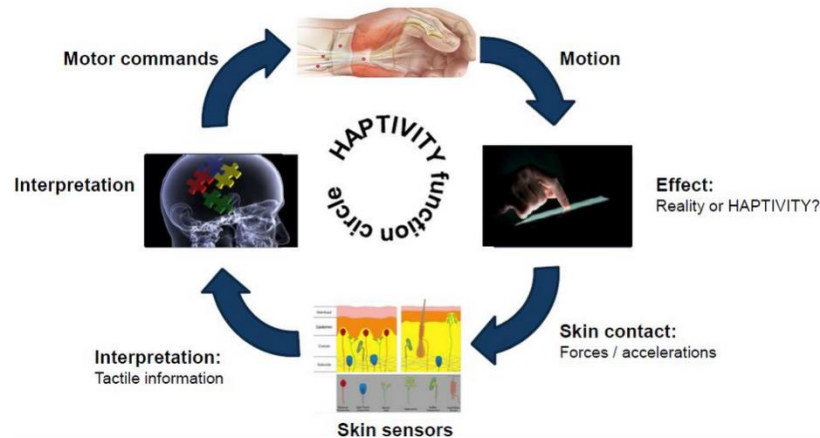

Figure 3. Biological circle of human reception of a haptic event [Source: Kyocera]

The proposed technology does not have to be limited just for touch screen implementations. Users are commonly familiar with transparent glass or plastic plates when they are pressing a touch-sensitive surface. However, there are many different ways of interaction between users and HMIs. While working on this Master's Thesis and looking for appropriate solutions for implementing haptic actuators into displays, the company was involved in a project in which an automotive customer expressed the wish for haptic feedback above the driver's armrest. In this particular application, the driver is in contact with an opaque wooden overlay when he wants to open the window or set the rear-view mirror. There is a conventional touch sensor beneath it, but if haptic feedback would come along at the same time, the enthusiasm would definitely raise. The actuator stays the same, but the difference is in the holder design. This is an example how the technology, once it has been established, can be implemented in different HMI devices and have additional positive outcomes for the company's future projects.

2. BASICS

2.1. Human-Machine-Interface

The Human Machine Interface affects the market success for Smartphones and Tablets as well as for handling industrial devices and in automotive industry [7]. Compared to other sensory devices used in the interaction with machines such as vision and audition, haptics is considered more „direct“. The HMI can be found everywhere where a menu is represented on a display and a dialog between the human and display occurs which leads to an interaction [8]. HMI explains the way how humans and machine communicate with each other, the ways how a human submits its wishes and instructions to the machine and in which form the machine carries out these instructions and ensures the result.

Fig. 4 represents the way how a HMI is built up. The input element of the entire system might be a certain task requested by the user, such as changing a radio station. The current output can be compared through the machine's feedback with the originally selected task. If it differs from the desired result, the process can be repeated until successful completion is achieved.

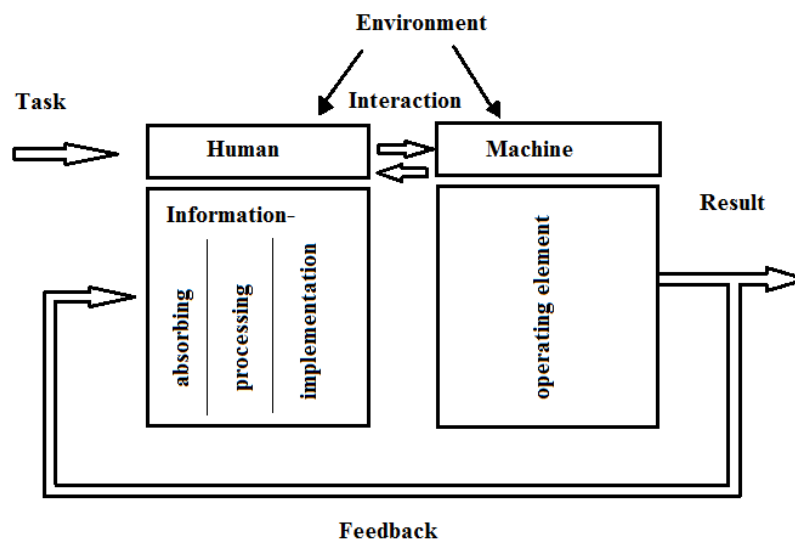

Figure 4. Structure of a Human-Machine-Interface [9]

At the beginnings of the computer technology, the interface was called Computer User Interface (CUI). The inputs were text-oriented and the user actually had to enter the requests and commands. The HMI technologies today still work mostly with visual interaction. After activating an input, the user sees the performance on a screen through an interactive feedback. That means that on touch screens, when the user straightly touches the surface, the result is just shown on the display.

While working with mechanical components on the other hand, the direct interaction occurs on the fingertips in form of a counter-pressure. This kind of interaction is related to touch screens with haptic simulation. This is a technology where the screen is moving. More precisely, when the user touches a button in order to perform a function, the screen surface is moving/vibrating, for example, in a short vertical motion. This event simulates the feeling of a

real keystroke. The motion of the screen can be achieved in different ways, depending on the actuator being used. The mostly used methods are the use of piezoelectric effect, electromagnetic actuation or electrostatic field.

The evaluation methods that have been applied in the literature to haptic interactions were categorized, including virtual environment, control, device and user (Fig. 5) [10].

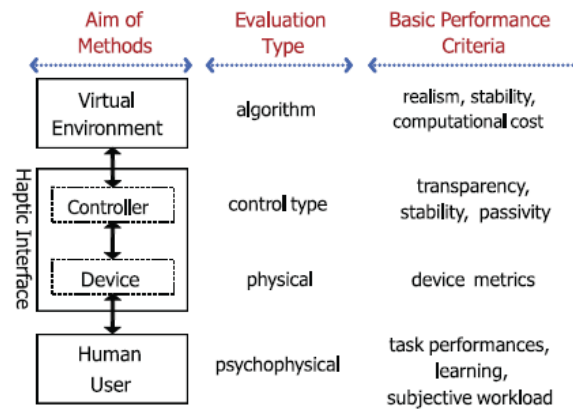

Figure 5. Classification of haptic rendering evaluation techniques and their corresponding basic performance criteria [10]

Touch screens are not likely to ever go away. For this reason, visual interfaces should be developed in a way that the amount of time the user spends looking and interacting with them is reduced.

2.2. Human senses and perception

While interacting with the world around us, we gain different sensations of information to guide us [11]. These include the visual, auditory and tactile sensations, and this collection of sensory information is easily integrated within the human brain, permitting our functions to manipulate objects with great utility. In opposition to these relations, the interface between humans and computers is limited in the sensory modalities available by still being strongly dependent on visual feedback.

Typically, it is believed that vision and auditory sensing convey most information about an environment and they have been widely investigated over the last few decades by engineers and scientists. The skin nerves can be simulated through six types of receptors and three types of stimuli: mechanical, electrical and thermal [12]. Vibration or pressure are modalities which can stimulate these receptors.

Table 1. Comparison of the body's sensors [12]

| Information capacity (bits/s) | | Temporal acuity/sharpness (ms) |
|-------------------------------|---------------|--------------------------------|
| Eye | $10^6 - 10^9$ | 25 |
| Ear | 10^4 | 0.01 |
| Fingertip | 10^2 | 5 |

Our senses are tools for perceiving environmental information [13]. Each of these sense modalities is influenced by many factors, such as the type of received and accepted data, the sensitivity to the data, the information processing rate or bandwidth, and the capability of the receptors to adapt to the received data.

- Visual perception

Visual perception provides currently most of the sensory feedback in the task of a GUI⁷. However, visual information is often important until an action is initiated, usually by pressing a button. Simply touching an object does not require added visual sensation.

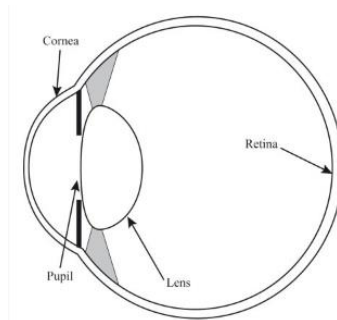

Figure 6. Schematic drawing of the eye [14]

The visual sense is based on the level of absorption of light energy by the eye and the conversion into neural messages. The wavelength range for human eyes is between 0.3 and 0.7 μm ⁸. The dimensional resolution is determined by the density and type of photoreceptors in the retina of the eye. Different factors limit its functionality. Some of them include the size of the pupil, the stimulated area of the retina, the eye movement and background light [14].

- Auditory perception

Auditory alerts are used in HMIs usually to signal an error or the completion of an operation. This is mostly quite straightforward to include into the HMI feedback because speakers are easy to implement into many modern systems.

The human auditory system receives sound waves through the outer, middle, and inner ears. These sound waves are then transformed into neural electrical signals within the inner ear. The audible signal frequency ranges from 16 to 20 000 Hz and is most efficient between 1 000 and 4 000 Hz [13]. A sound can be described in terms of the sound wave's direction, frequency, and intensity or loudness (which ranges from 0 to 160 dB).

- Haptic perception

Touch is a much more immediate sense than either sound or light: „If someone touches you or pokes you, you'd better pay attention“ [15]. Audio feedback can have a similar impact, but lack of background noise has to be assured. Even if there is a combination of those kinds of

⁷Graphical User Interface

⁸1 μm = 10^{-6} m

feedback, if they are separated by as little as 500 milliseconds, the brain perceives them as separate events, instead of being synchronus.

The skin is the body's largest organ and acts as a sensory port of external stimuli with different kinds of sensors. The skin's complexity affects the design and performance of tactile HMIs. In order to design better interfaces, modalities of the skin's sensors must be understood as well as their response to external stimuli.

The major part of most research works is related to skin without hair because most of the applications developed so far are used on the palm and finger. In more detail, the limits of the human hand must be known in order to use human perception as an evaluation tool for those interfaces. Table 2 shows the output capabilities of the hand.

Table 2. Output capabilities of human hand [10]

| Parameter | | Value | Notes |
|-----------|---------------|------------|---|
| Force | Maximum | 50/60 N | Finger/wrist |
| | | 100 N | Elbow and shoulder |
| | Bandwidth | 5 Hz | |
| Motion | Maximum speed | 17.6 rad/s | |
| | Bandwidth | < 2 Hz | Active touch for sensing |
| | | 2-4 Hz | Voluntary movements |
| | | 4-8 Hz | Skilled actions: hand writing, typing, tapping, playing instruments |
| | | 10 Hz | Reflexive actions |

Haptics is the science of applying tactile, kinesthetic, or both sensations to human-computer interactions. It refers to the ability to sense and/or manipulate objects in a natural or a synthetic environment using a haptic interface.

The main differences in the haptic feedback technology can be seen in Table 3. Tactile feedback refers more to the sensation of pressure rather than temperature or pain. Kinesthetic, on the other hand, is related to the feeling of motion. It refers to the sensation generated in muscles and joints.

Table 3. Definition of haptic feedback technology [Source: Next System]

| | | |
|--------|-------------|------------------------|
| Haptic | Tactile | Mechanical stimulation |
| | | Thermal stimulation |
| | | Chemical stimulation |
| | | Electrical stimulation |
| | Kinesthetic | Force |
| | | Position |
| | | Direction |
| | | Angle |

The following table represents the main characteristic and comparison of touch, haptic touch as well as mechanical buttons.

Table 4. Different types of buttons [Source: Next System]

| Control element | Touch | Haptic touch | Mechanical |
|---------------------|-------|--------------|------------|
| Hygiene | + | + | - |
| Component reduction | + | + | - |
| Cost reduction | + | + | - |
| Lifespan | + | + | - |
| Intuitiveness | + | + | 0 |
| Operating safety | - | + | + |
| Blind operating | - | + | + |
| Haptic feedback | - | + | + |
| Force sensing | - | + | + |

- Kinesthetic

Kinesthetic feedback is perceived through muscles and joints. Touching an object provides through kinesthetic feedback information about the approximate size, whether a lighter or heavier material was used, and in which position the object is relative to the body [16].

- Tactile

In contrast, tactile feedback is perceived more through the fingertips. The stimulation of the receptors under the skin informs the person about the temperature, vibration, surface texture, actuation force etc.

“Tactile sensation can be more emotional and personal than sight or sound and can therefore enrich the user experience and perception of the interaction [3]”. For tactile feedback, the central issue is not the efficiency of driving an actuator. It has been shown that frequencies above a few hundred Hertz do not provide good tactile response and additionally consume unnecessary power [17].

However, haptic actuators usually cause the movement of the entire device. Nevertheless, the fingertips are one of the parts of the body with the highest concentration of sensors. The fingers are also the most precise tool and in use when working with a touch screen. That is why they are the best channel for haptic information. This kind of information can be felt even five times faster than visual information due to the fact that tactile information passes through less processing phases than visual information. Most haptic effects are produced by stimulating the nerve receptors in the finger by either the motion of the touch surface or vibration of the skin [3].

Commonly, haptic pulses are defined by frequency and amplitude. Operating bandwidth provides the frequency range within which a system can operate and defines the maximum speed of response at the given excitation level, wherein amplitude is the strongest differentiating factor, while the perception of frequency is mostly subjective. Nevertheless, the wider the bandwidth, the faster the response [18]. The human fingertip is at its most sensitive at frequencies around 250 Hz, so the most haptic actuators have an optimum frequency within the range from 100 to 300 Hz [19].

2.3. Haptic technology

The haptic sense has been explored for human-computer-interaction for a longer time. Despite the fact that people are experiencing haptics, the term is often unknown to consumers. It firstly became popular as the vibrating alarm in phones. It indicates either an incoming call or message and the user's attention is drawn to a tactile alert. More and more companies are moving towards the use of capacitive touch buttons in order to replace mechanical controls. The major disadvantage of touch screens, which are increasingly replacing traditional user interfaces, is that there is no physical or mechanical feedback when the screen is pressed or when an event occurs. A solution exists and it is called haptics. The word "haptics" is derived from the Greek phrase "I touch". It is possible to provide the user mechanical feedback by applying forces of vibrations to simulate specific events or effects. This kind of technology is adding tactile feedback to electronic devices through the use of vibrations. The human finger is getting the impression that an actual button is being pressed. Haptics technologies are advancing, but the success lies in the significance it brings to user experience. It has more usage than just serving as an alert or confirmation. The feedback could increase as the user zooms in to the maximum extension of the view. Faster scrolling could be an example for faster tactile feedback. When haptics is used with audiovisual feedback, or generally being well designed, it can extremely upgrade the experience.

Touch interface is so intuitive that even children can unlock a smartphone. However, these screens have a restriction in that there is no mechanical feedback for user interactions. In automotive industry, this kind of feedback enables closing the loop between driver, vehicle and environment. In situations where audible or visual feedback is not appropriate, for example in case of visually-impaired people, a tactile interaction could be used as the main technique.

When all mechanical specifications are selected, a control system is required to drive the actuators to create different haptic effects. The design of the system, hardware and software together should be able to detect the touch and create a haptic feedback in less than 30 ms. For haptics it is normally preferred to have a quick response.

2.3.1. Principles

In form of a block diagram shown in Figure 7, everything starts with a touch screen equipped with possibly capacitive buttons. When a touch occurs, it is identified by a touch screen controller which sends a signal to the microprocessor controlling and supervising the overall haptic system. It then decides which haptic feedback should be played back and transmits the correct waveform information to the driver. It closes the loop by forwarding the information to the actuator which creates different signature vibrations felt through the user's fingertips when activating a touch key.

Each haptic effect is created by driving the actuator for a specific intensity, and by using a precise sequence for a predetermined period of time resulting in a haptic waveform for that specific effect. The required haptic waveform for each effect does not change from design to design, but the algorithm on how to drive the actuator does. Each algorithm considers the characteristics of the used actuator, the mass of the device and the dynamic response of the

mass being vibrated. In summary, each algorithm must be developed for the specific mechanical design in order to produce the correct haptic effect.

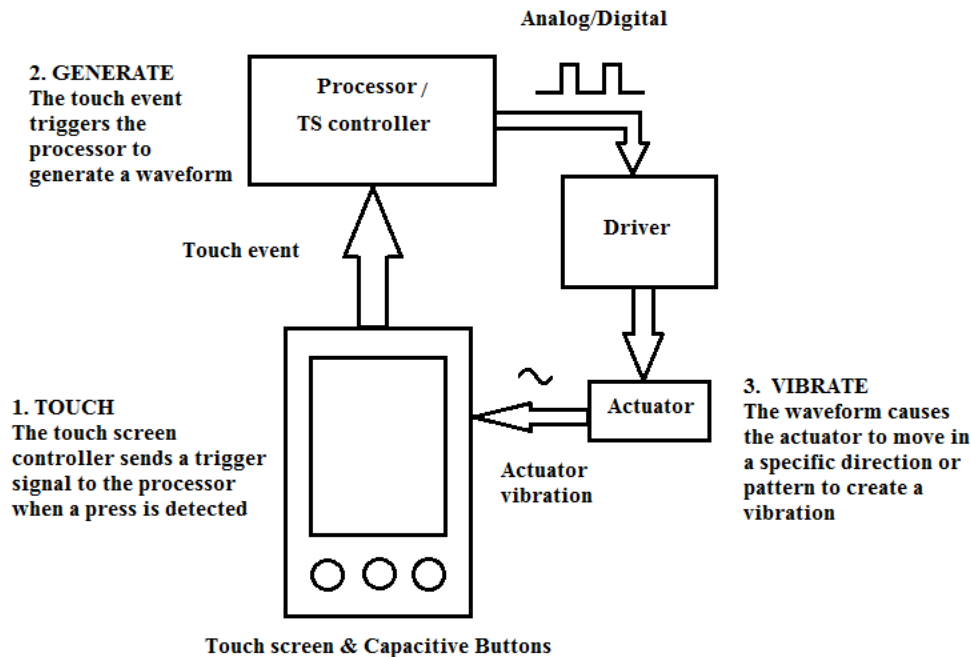

Figure 7.Haptics Ecosystem

Summarized, the haptics ecosystem consists of three main parts:

- **Actuator** – vibrates the device in a specific way; actuator type determines the quality of the felt effects
- **Driver** – located within the electrical system design and connects the controller and actuator; output high or low voltages depending on the type of actuator
- **Software** – generates the waveforms (sine wave or PWM⁹) and is attached to the processor, microcontroller or integrated driver depending on the availability of the system

Generally, a haptic driver is necessary because microcontrollers are typically unable to provide enough current and power to drive the actuator themselves. This is important when starting the actuator because quick starts are extremely important for high quality haptics.

There are two techniques used within processors to ensure quick effects: overdrive and active braking. The actuator can be overdriven to reduce the time it takes to reach its vibration level. The actuator is applied with a voltage higher than its maximum rated (continuous duty) voltage for a short time. The effect can be achieved with a PWM signal or by using the two GPIO pins on the processor. During the active braking phase, the actuator is slowed quicker by applying a reverse voltage until it stops.

⁹Pulse-width modulate (signal)

2.4. Types of haptic feedback scenarios

Just as HD¹⁰ TV offers higher resolutions than standard TVs to create a sharper image, HD haptics lets users feel more observable vibration effects. Using advanced drive signals a variety of patterns can be used to express information to the user. Depending on the situation, different effects can be achieved. For example, double click sensations for a “long press” to access additional menus or a strong ramp up for starting/stopping a procedure. These effects can be created through different driver chips.

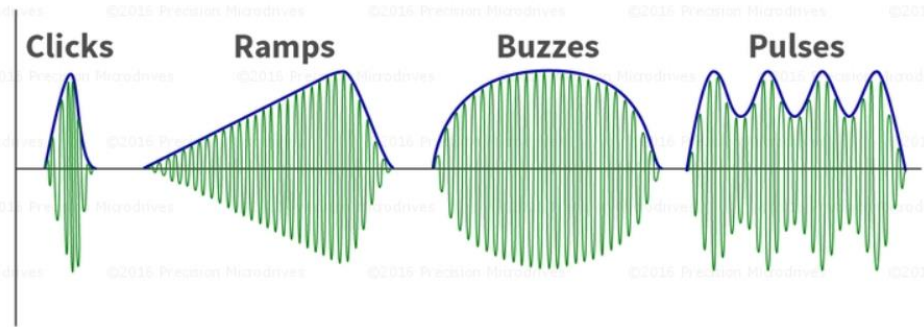

Figure 8. Different vibration profiles for haptic effects [Source: Precision Microdrives]

The attention is paid on the click effect which is short and powerful. The quality of the effect depends on how quickly the actuator starts and stops. Haptic drive techniques of overdrives and active braking are very important for user perception. Double or Triple clicks are also available, which might be useful to signal an input error.

Haptic technology includes different kinds of feedback which can be useful in everyday life [2]. A simple example is a car's parking sensor which brings the steering wheel to vibrate if the car comes upon within 50 cm of an object. The vibration just informs the user of an event, but in reality, the driver would for sure prefer to know how far away the car actually is from an object. Haptic feedback can transfer this information by changing the vibration frequency. This feedback can replace the auditory beeping feedback found on current sensors which shows to be practical in loud environments or for hard-of-hearing people.

Haptics can also be an element of fun. Many people play games on their devices. Tactile feedback can be used to make the gaming experience much better. For instance, the user could feel crashes and bumps in a racing game and so on.

Haptic technologies can be generalized in two dimensions to differentiate between simple vibration and HD haptics on one hand, and the localization of feedback, from whole body actuation to localized, on the other [20]. Further, the technology can differ according to the size and weight of a device and the quality of feedback required.

The way how the feedback is felt in the end can depend on a variety of factors [16]. For instance:

¹⁰High Definition

- Triggering force
- Amplitude and frequency used for moving the surface
- Acceleration of the finger
- Vibration behavior
- Total moving mass
- Timing of the surface displacement
- Nature of the surface material
- Room temperature...

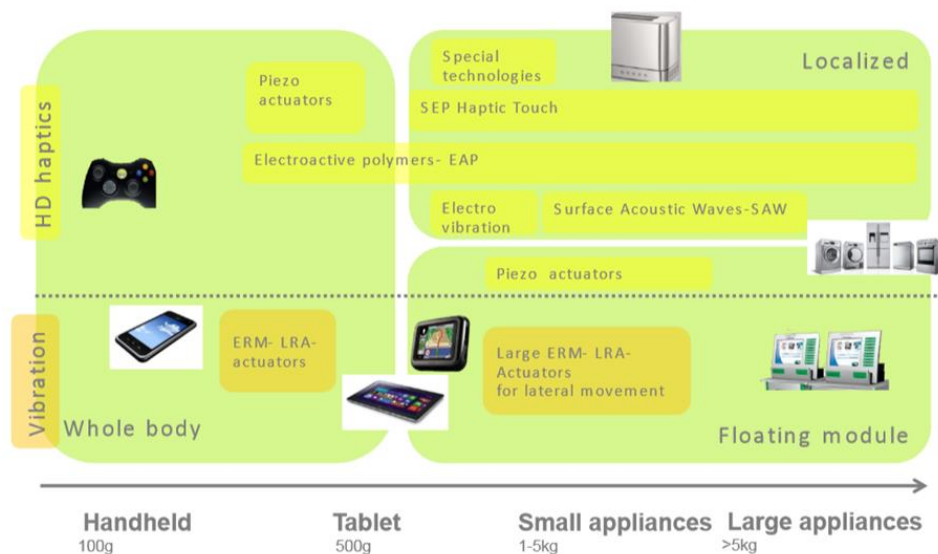

Figure 9. Haptic technologies [20]

In principle, a haptic feedback in a vehicle can be implemented with two main types [9]:

- Real haptic feedback (through an adaptive variable surface)
- Simulated haptic feedback (through vibration of the surface)

From a technical perspective, an interface with simulated feedback is easier to implement compared to the case of real feedback. The main reason is that, according to the current state of the art, an adaptive varying surface is very complicated and costly to produce.

Real haptic feedback is more often achieved by Coulomb's force, the principle of attraction between positive and negative electrical charges. Smooth glass surfaces can be felt like sand or a rock, by changing the way how the human finger perceives the friction from the surface. This method is explained in more detail in the subchapter [3.6](#).

3. METHODS FOR PRODUCING HAPTIC FEEDBACK

- Actuator design

The trend from mechanical control elements to digital pushbuttons is moving forward. One of the most important elements of every haptic device is the actuator. The question is: “What makes a good haptics actuator”? Their selection and design will influence the quality of the haptic impression. This chapter will explain the most commonly used working principles.

Some of the key considerations when selecting an actuator are:

- Response time: how quickly it can produce a certain effect after sensing finger pressure
- Vibration strength: the maximum acceleration achievable by the actuator
- Bandwidth: the frequency of effects it can create
- Mounting: whole-body or localized actuation
- Power consumption: dependent upon the length of the vibration and the mass being moved

Which option eventually comes to use depends on:

- Application area
- Available space
- Desired performance
- Cost constraints

Obviously, it would be highly difficult to find the tactile technology that is ideal for every application because each technology represents a compromise according to the above requirements.

The type of haptic effect can differ in complexity from simple vibrations to effects driven by complex mathematical models, represented in Figure 10. Simple vibrations are still used in phones, while high-fidelity force-feedback produces a more authentic response.

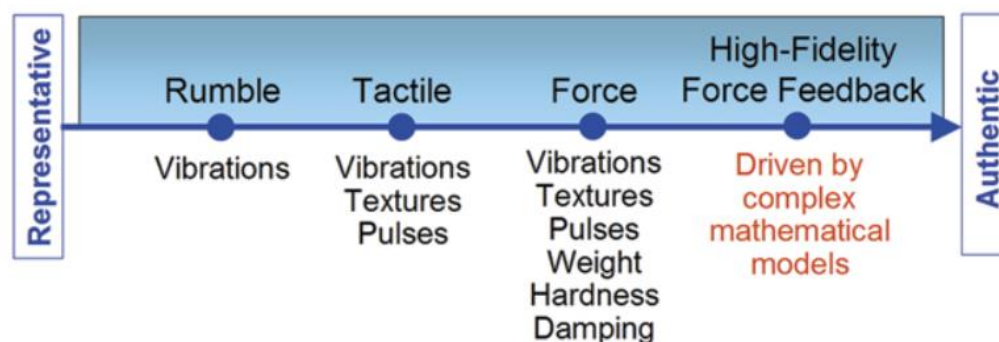

Figure 10. Spectrum of haptic feedback [Source: Immersion Corp.]

In terms of technologies, there are three main technologies most manufacturers are working with. This includes inertial and piezo actuation. Furthermore, several new technologies for direct touch interaction will also be presented. The possible methods are listed in Table 5.

Table 5. Methods for producing haptic feedback

| Vibro-tactile feedback | | Friction | | |
|--|---|--------------------------------|-------------------|--|
| Inertial actuators (ERM¹¹, LRA¹²) | Moving the surface with oscillating rotary or linear-mass actuators | Electrostatic principle | Surface Actuation | Moving the surface with electrostatic attraction |
| Piezoelectric actuators | Bending the surface or lateral movement with piezo disks or strips | | | CEI ¹³ |
| Voice coil motors | Use magnetic forces with the coil as the vibrating part | | | |
| Solenoids | Use magnetic forces with the permanent magnet as the vibrating part | | | |
| EAP¹⁴ | Moving the surface by contraction and expansion | | | |

A third actuator technology might be the electro-tactile feedback but the whole design is bigger, weightier and harder to control so they are less useful in many situations and are still being researched and improved [21].

The human finger is not able to feel the difference between a vertical/horizontal movement or vibration of the surface. Only the scalar value of the acceleration matters. That is why there are two main approaches to realize a surface vibration [22]. (See Fig. 11)

¹¹Eccentric Rotating Mass

¹²Linear Resonant Actuator

¹³Capacitive-Electrosensory-Interface

¹⁴Electro-Active-Polymer Actuation

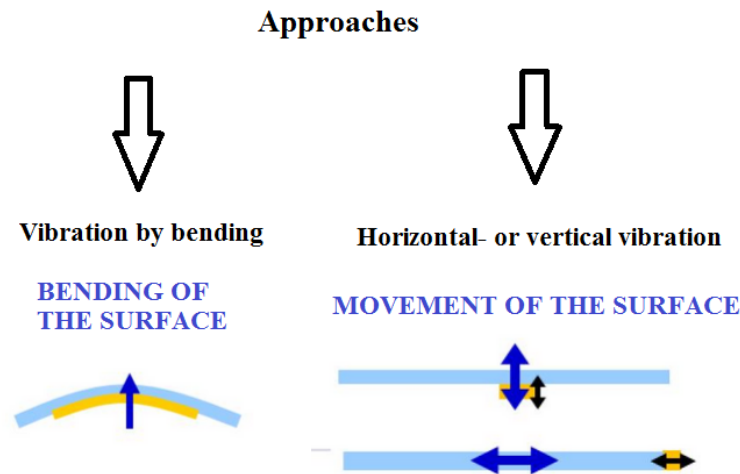

Figure 11. Approaches to realize a surface vibration [22]

3.1. Inertial actuation

The most effective tactile trigger method which is used in almost every mobile phone for achieving a vibration alert is the inertial technology. The most commonly used types of haptic actuators are Eccentric Rotating Mass (ERM) and Linear Resonant Actuator (LRA) because they are small and lightweight, but still able to produce a strong vibration [23]. Both actuators are often designed to shake the whole device. If a motor runs an eccentrically mounted mass, it is called eccentric technology. The motor is mostly implemented with a simple on-off switch. In the linear resonance technology a spring-mass system is vibrating longitudinally. It is controlled by the sinusoidal input signal of the spring-mass system. For generating the wanted mechanical feedback, a modulation of the waveform is needed. However, because of the absence of haptic information, they are not suitable for simulating certain types of tactile experience, such as the feel of touching a texture or shape.

LRA can achieve lower power consumption than an ERM motor. The main reason for that is because they are driven at the natural resonant frequency of the spring element. The next difference is that LRA produces linear movement, while ERMs create vibrations in a plane perpendicular to its rotor due to the rotating motion.

Although being used for a long time, even the latest version of these actuators cannot ensure HD haptic feedback. Theoretically, localized haptics could be achieved by using one actuator per key, but this option could be expensive. The cost of components alone would make it an inappropriate solution with extra mechanical integration challenges.

Inertial actuation used in phones can be used for tactile feedbacks, but bringing the entire device to vibrate will not replace the more complex feedback of mechanical buttons. Therefore, the so called “whole-body actuation” is a low-cost solution for mobile manufacturers.

3.1.1. ERM – Eccentric Rotating Mass

ERM is the most common vibration motor [24]. A vibration is felt as the motor starts to spin when it is driven with a voltage. In other words, it is a DC¹⁵ motor with an asymmetric mass connected to the shaft [25]. The technology has been around for a long time which makes it one of the most cost-effective options.

Summarized, the main characteristics of ERM are:

- Low cost
- Vibration frequencies within 90 and 200 Hz [26]
- Very good durability
- Long response time (not desirable for haptics)
- Noisy - might be annoying



Figure 12.ERM actuators [Source: Precision Microdrives]

The principle is simple. A haptic driver chip drives the motor differentially, so the motor spins when a positive voltage is applied and brakes in case of negative voltage [27]. As the ERM rotates, the centripetal force of the mass is asymmetric, resulting in a net centrifugal force which causes a movement of the motor. With a high number of revolutions per minute, it is constantly being moved by these forces. This repeated movement is perceived as a vibration [28].

A larger mass with a bigger offset from the shaft would produce more force and more vibration amplitude, represented by the following formulas for frequency and force [29]:

$$f_{\text{vibration}} = \frac{(\text{MOTOR}_{\text{RPM}})}{60} \text{ (Hz)} \quad (1)$$

$$F_{\text{vibration}} = m * r * \omega^2 \text{ (N)} \quad (2)$$

where:

m = the mass of eccentric weight

r = mass' offset distance

ω = speed of the motor (rad/s), $\omega = 2 * \pi * f$

¹⁵Direct Current

However, trying to use such motor-based actuation for other haptic feedbacks would quickly deplete the battery. Another disadvantage is the limitation in creating advanced waveforms. The frequency and amplitude of the waves are joined together to the input voltage, so the user is not able to change any of these variables. It is mostly possible to create just different combinations of pulsing or speed. Some properties such as speed can be improved by using techniques such as overdrive and driver chips. Start-up time is usually between 50 and 100 ms [27]. In this range the motor reaches 90% of the rated acceleration. Stopping the motor has a similar time frame. Due to these reasons, 100 to 200 ms would be required for a very simple haptic event like a click. Additionally, if the application needs repeated haptic events, the latency related to the motor-based haptics could be unwanted. Further, an ERM creates audible noise due to the spinning motor.

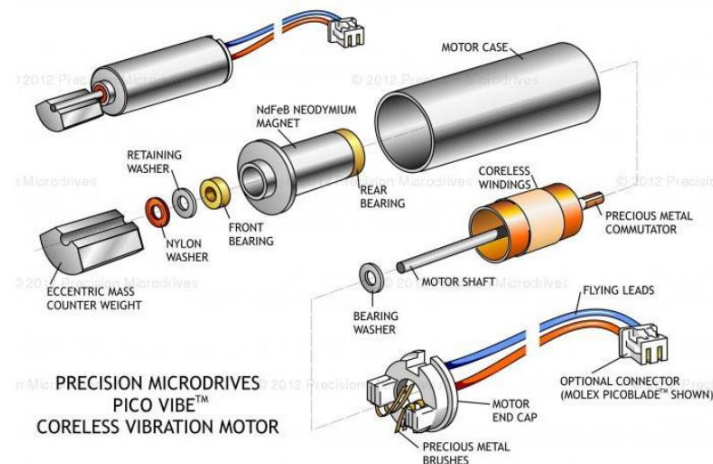

Figure 13. Structure of ERM [Source: Precision Microdrives]

A wide range of haptic effects can indeed be created by using techniques that modulate waveforms, frequency, amplitude or duration. However, the waveforms must be tuned for the response characteristics of the integrated system. This is especially critical when trying to reproduce the sharp feel of a mechanical button which has to be short and precise, lasting approximately 20 ms. Due to their rotational behavior and vibrations in two axes, they are more suitable for situations where the user is holding the device, such as joysticks or steering wheels [29]. In conclusion, ERMs are more suitable for whole-body effects.

3.1.2. LRA – Linear Resonant Actuator

It uses a quite different mechanism compared to ERMs. It consists of a spring-mounted mass that oscillates up and down and vibrates in linear vibratory motion. The shape is mostly similar to a small button cell, but can come in different shapes and sizes. The benefit is that it uses the principle of resonance which leads to power savings. Although the power consumption rate is about 30% lower than in the case of ERM, the technology is locked in this range of frequency. If it leaves the resonant band, efficiency and performance decrease noticeably.



Figure 14.LRA actuator [Source: Precision Microdrives]

Shortly, LRA actuators use a magnet, spring and voice coil to cause motor displacement. The magnet is stimulated by an electromagnetic field in the voice coil and the spring ensures the magnet, which is attached to a mass, to oscillate back and forth. The spring keeps the central mass under slight tension. It essentially uses the principle similar to that of a loudspeaker.

Despite being locked in terms of frequency, the amplitude of the input signal can be modulated to add an extra degree of freedom, whereas emulating unique waveform profiles which cannot be achieved with an ERM.

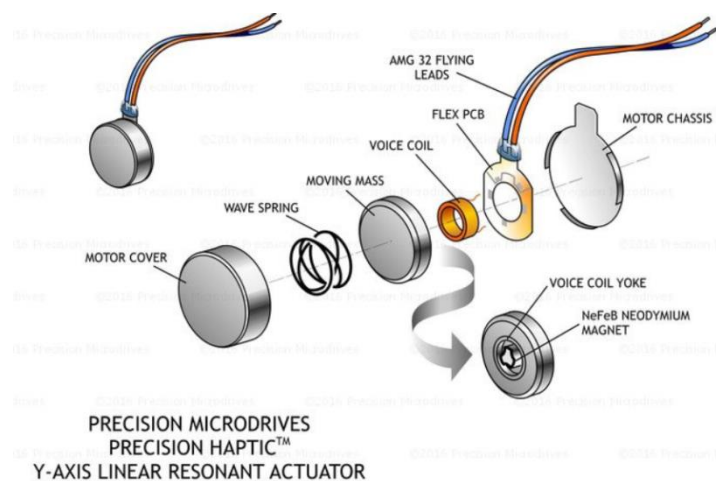

Figure 15.Structure of LRA [Source: Precision Microdrives]

Depending on the manufacturer, start-up time is between 40 and 60 ms which represents a minor improvement over the ERM start-up time, but this is still rather slow [32]. Since LRA is driven at the resonance frequency, the input signal will be sinusoidal at the nominal frequency of the spring-mass system, usually about 175 Hz. Due to the LRA's internal construction, it requires an alternating current to produce the magnetic field, so they only work effectively when driven with an AC¹⁶ signal. The cylindrical forms are rather used in touch screens because coin actuators vibrate in a plane perpendicular to the pressed force of the finger. In this case, LRAs can be mounted directly behind the screen, while ERMs are best mounted at the side [29].

¹⁶Alternating current

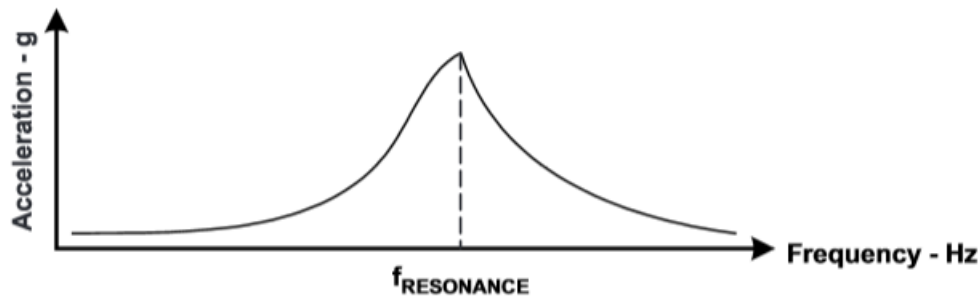

Figure 16. Typical LRA Response [30]

The challenging narrow frequency bandwidth over which they have an adequate haptic response can be solved by using a driver with the possibility of auto resonance tracking. Such drivers automatically detect the LRA resonant frequency in real time, and additionally include a braking algorithm to prevent the LRA ringing at the end of waveforms, so the user can get the short haptic sensation. The sales engineer Chris Lisseman from the British company Precision Microdrives suggested this. A possible driver is for example the Texas Instruments DRV2603 or DRV2605 [30]. Finally, an array of LRAs may be implemented in order to get button effects, though in fixed positions [31]. Local vibrations can be achieved with piezoelectric actuators discussed in subchapter [3.2](#).

- Implementation of Inertial Actuators

The forces produced by vibration motors are actually multi-axis vibrations characterized by individual directions magnitudes. That is why the direction of vibration for producing tactile feedback has to be considered when designing the mechanical layout of a device.

The direction with best results is almost always towards the user. The best position of the vibrating motor inside of a device will depend on the devices application and how the user will operate it. Joysticks and touch screens differ a lot because they are not used in the same way. This affects the appropriate placement of the actuator. It also affects the choice of actuator because different forms produce different vibrations in different directions.

Because ERMs have a rotational behavior, their movement is in two axes, while LRAs due to the linear motion produce vibrations in just one. Motors in a coin form are designed to be mounted or secured on their back surface with an adhesive pad. The orientation has to be considered for achieving the feedback in the desired way.

Although ERMs can be used, in touch screen applications LRAs are more suitable. With quicker response times and vibrations produced in only one axis directly towards the user, they represent a favorable solution for implementing the haptic technology. They are also easy to mount due to their low profile and self-adhesive feature.

Represented in Figure 17, for coin or cylindrical ERMs, the vibrations are experienced in both Z and X axes. Depending on the LRA design, vibrations are generated in the Z or Y axis.

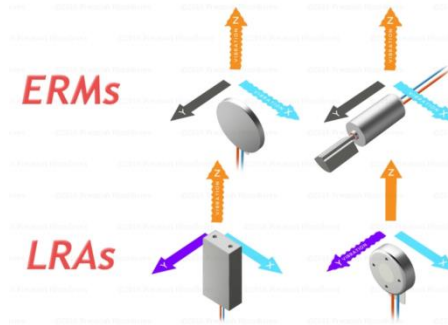

Figure 17. Vibration directions depending on form factors [Source: Precision Microdrives]

If the designer decides to mount the actuator inside an enclosure, an important aspect is that the motor is held tightly to the enclosure since space between the vibrating motor and enclosure can result in audible noise and even decrease the vibration amplitude.

3.2. Piezoelectric Actuation

The use of piezoelectric effect is a new application of an old product. In contrast to inertial actuation, piezoelectric-actuation systems can be designed to produce haptic effects by either bending the touch surface or pushing the surface towards the user, resulting in translational motion.

Figure 18 shows the principle of the piezoelectric effect based on a quartz crystal. Applying voltage (electrostatic field) across the crystal will cause mechanical movement of the centers within the crystalline structure.

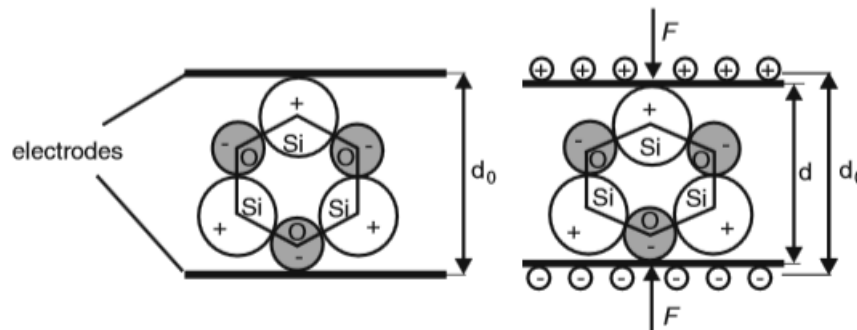

Figure 18. Crystal structure of quartz in initial state and under pressure 40

The transformation from electrical into mechanical energy happens without any moving parts. This gives fast response time and high dynamics compared to other actuation principles. The most frequently used types are bending actuators and actuator staples.

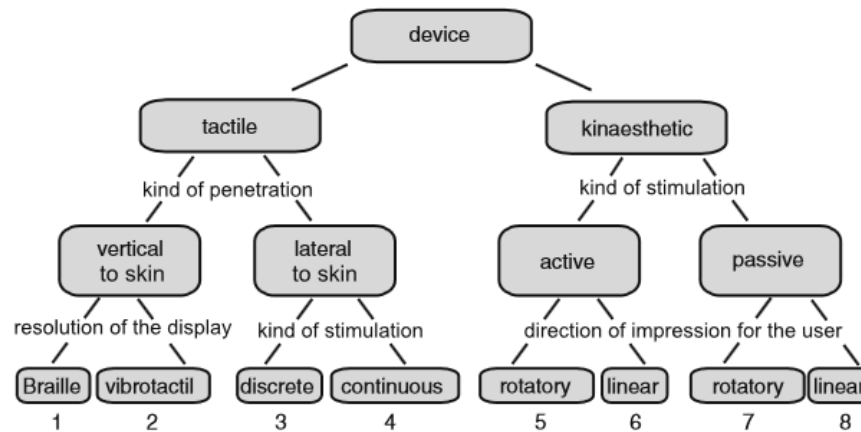

Figure 19. Decision tree for the selection of a piezoelectric actuator type [32]

For the design of tactile systems, the application area plays an important role. The directions of perception of the skin might be normal (vertical) or lateral.

Braille displays have to push a force against the user's finger. The counterforce is about 200 mN¹⁷ at displacement of around 100 µm. The requirements on the dynamics are in the range of just several Hertz. Bending piezo actuators could fulfill such requirements.

Vibro-tactile displays require higher frequencies but smaller displacements and forces. Bending disks or staple actuators might be used in those applications, wherein the skin surface is excited into oscillations. The feedback is generated by the amplitude of the oscillation, not by the penetration depth.

This type of actuator is not motor based, has a faster response time and is smaller than both ERMs and LRAs. Though a variety of factors need to be considered, the intensity of acceleration of the touch surface is a dominant factor. The given acceleration can be reached more quickly allowing a shorter duration of the haptic event. This also leads to power savings.

The standard piezoelectric actuator technology uses either a thin strip (beam) or a round disk structure, thus creating vibrations when voltage is applied. Technically, these actuators do not vibrate, but produce a movement in form of bending for beams or vertical movement in the Z-axis for disks. They return back to original state when voltage is decreased. A company from Netherlands, AITO, developed a promising technology with buttons using piezoelectric disks. After talking to their operating officer, JockumLönnberg, the method was excluded for applications in touch screens, because AITO implements their actuators just beneath non-transparent surfaces.

¹⁷mN – 10⁻³ N

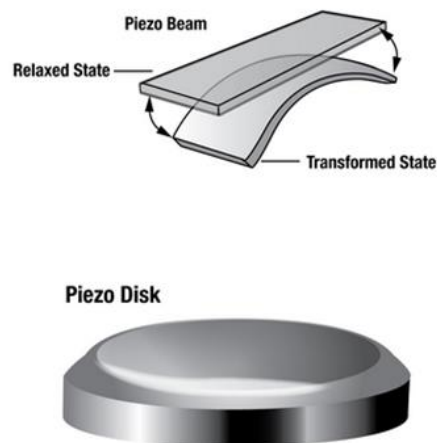

Figure 20. Forms of piezoelectric actuators

Table 6. Comparison of piezo disks and strips [Source: Texas Instruments]

| Piezo disk | Piezo beam |
|------------------------------------|--|
| Pushes the screen in Z-direction | Can vibrate the glass from the side in lateral direction |
| Requires multiple elements | One or multiple elements |
| Audible noise might be undesirable | Resonant tone can vibrate the glass silently |

The main challenge facing the developers is the need for high voltages in order to actuate the piezoelectric elements. Depending on the manufacturer, voltage varies in the range from 50 to 200 V. The number of piezo layers decreases for higher voltages. For e.g., at 150 V the actuator has just about 4 layers, while at 50 V the number of layers might be 24. At higher voltages, the actuator's capacitance is lower and less current is required to drive such actuators. On the contrary, lower voltage piezoelectric elements are more expensive. So the user is actually paying for lower voltages. But in terms of performance, they are both characterized by similar features. Accordingly, the design process should take into account the adjustment between piezoelectric element costs and drive electronic costs.

Piezo-based haptics practically neither have frequency nor amplitude constraints within the interesting performance range so a variety of waveforms can be used. For example, though the exact tactile feedback similar to pushing a button might not be replicated, with piezoelectric actuators it can be achieved extremely close.

HD and localized haptics is possible by using multiple piezo modules. Individual parts of the screen can be affected by the actuation. For instance, each touch point (finger) could feel its own waveform response which is better than vibrating the whole device. Mechanically, it might be more difficult to implement because the screen must be mechanically suspended (i.e. to “float”) to allow for independent vibrations.

Key elements differentiating piezo actuators from inertial actuators:

- **Faster response time** – typically less than 1ms [Source: Texas Instruments]
- **Higher bandwidth** – provides more detailed haptic possibilities with greater number of effects
- **Lower audible noise** – unlike ERMs, they have no spinning mass to create mechanical noise
- **Stronger vibration** – piezo actuators are moving towards generating higher vibration strengths which makes them a great candidate for bigger screen implementations

Comparing the response time of the piezo actuator and the mechanical button being pressed by a user’s finger (Fig. 21), indicates that piezo actuators can almost recreate the button feel. Namely, the acceleration¹⁸ profile in Fig. 21 shows what the finger senses when it is touching or pushing a button, what appears to be very similar to the case when piezo actuator is used.

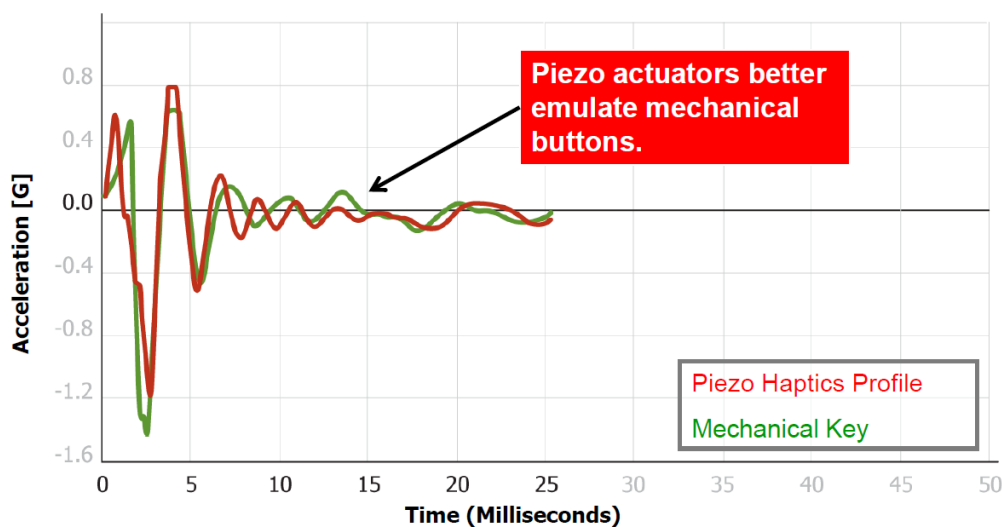

Figure 21. Response time of a piezo actuator and a button [Source: Texas Instruments]

The green line represents the acceleration our finger feels when we touch a button. This acceleration could never be achieved with an ERM actuator.

3.2.1. Types of piezoelectric actuators

When implementing a piezo-based tactile feedback system, the first decision should be whether to use single-layer (SL) or multi-layer (ML) piezoelectric actuators.

¹⁸G – m/s²

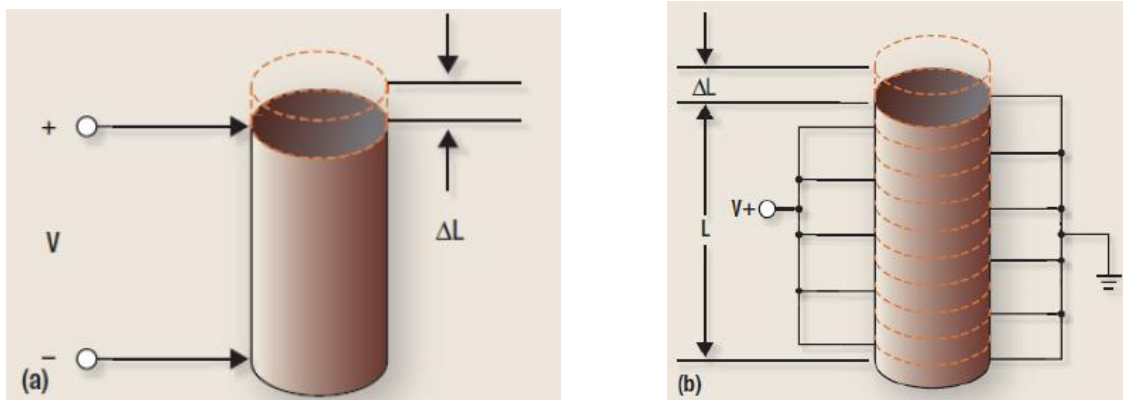

Figure 22. Types of Piezoelectric Actuators: a) SL, b) ML [Source: Texas Instruments]

A summarized comparison of the aforementioned two types of piezoelectric actuators is listed in the following table.

Table 5. Benefit comparison between SL and ML piezo actuators [Source: Maxim Integrated]

| | Single-Layer | Multi-Layer |
|------------------------|---------------------|--------------------|
| Cost | Low | High |
| Capacitance Load | Low | High |
| Voltage drive | High | Low |
| Force | Good | Good |
| Mounting | Limited | Good |
| Availability (sources) | Many | Few |

The information from Table 5 would suggest using a SL piezo actuator. ML piezo actuators might be less available and more expensive. The price is an important factor in solutions with more than one actuator. That is why an appropriate solution would be using multiple single-layer piezo actuators mounted behind or next to the display rather than a more expensive solution with one similar multi-layer solution. SL piezo actuators are available from many sources and are mass manufactured.

- Comparison to Inertial Actuators

Motor-based actuators typically require low voltages, but the currents can be large. Also, the run-on and turn-off characteristics of inertial actuators, especially ERMs, are insufficient for the short haptic response necessary for getting the “button-click” feeling.

LRA has a few advantages over ERM, including the use of less energy when vibrating and lower latency between turning on and producing a feedback. According to Texas Instrument’s designers, LRA has up to 2 times more force and uses 50% less power. The ERM motor has to start spinning and moving the inertial mass which makes it difficult to control particular vibration components.

Generally, due to moving the inertia mass, inertial actuators have a slower response time, while the lower bandwidth limits the types of effects they can create. On the other hand,

piezoelectric actuators have the fastest response time and largest bandwidth. The most important characteristics are listed in the following table.

Table 7. Actuator technology [Source: Texas Instruments]

| | ERM | LRA | Piezo |
|---------------------------------|--|---------------------------------|--------------------------------|
| Motion type | Rotation | Linear | Linear |
| Drive Voltage (peak to peak) | 10 V | 10 V | 150-200 V (SL) 30-50 V (ML) |
| Power consumption | 10 % of battery power (poor) | 5 % of battery power (best) | 7 % of battery power (good) |
| Bandwidth | 1-300 Hz | 175 Hz | 1-300 Hz |
| Response time | 40-80 ms | 20-30 ms | < 1ms |
| Size | Sizeable | Sizeable | Thin |
| Vibration source | Motor based; off center rotating mass | Motor based; spring + magnet | Bending ceramic strip/disk |
| Localized haptics | No | No | Yes |
| Whole device haptics | Yes | Yes | Yes |
| Cost | € | €€ | €€ (SL) €€€ (ML) |

○ Response time

From the response time perspective, it can be seen from Table 7 that inertial actuators achieve an average range of 30-60 ms, while the piezo actuator response time is less than 1 ms. This means that within the time a user gets one effect with an inertial actuator, 30 to 60 effects can be implemented with a piezo actuator. This is shown in the following Figure.

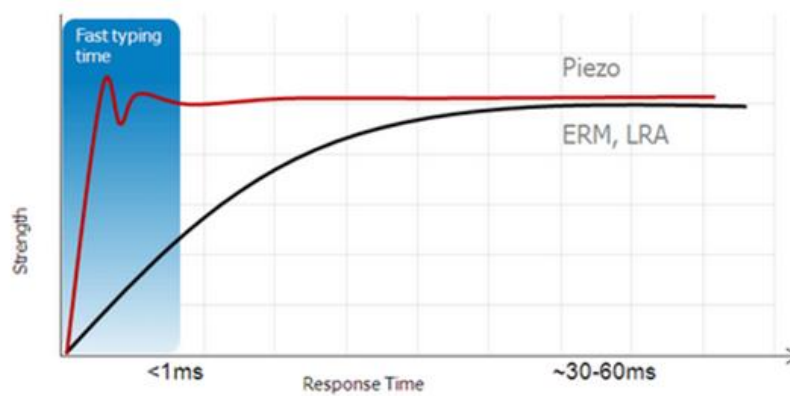

Figure 23. Response time [Source: Texas Instruments]

This property also makes piezo actuators very power/energy efficient. Less energy is used because it is possible to accelerate, run a waveform and go back to the start position much faster than with an ERM or LRA (i.e. less kinetic energy needs to be produced/dissipated). Basically, actuator acceleration is achieved faster so the duration of the tactile feedback can be shortened.

- Power consumption

Power should be calculated for the haptic feedback circuit from the power supply. Features that affect the resulting power usage [17]:

- Waveform amplitude, type and duration for each haptic event
- The number of events per second
- The power taken from the main supply for each haptic event
- The power consumed by the high-voltage circuit

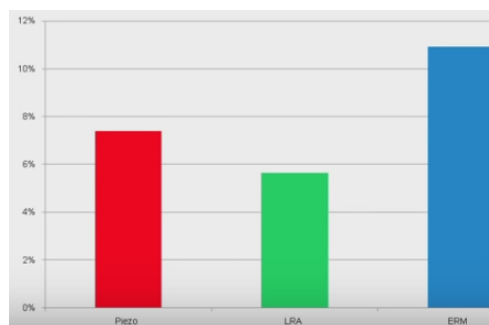

Figure 24. Power consumption [Source: Texas Instruments]

Texas Instruments tested the power/energy consumption of the three actuators as a percentage of a 1200 mAh¹⁹ battery. Figure 24 shows the amount how much power was consumed by the battery. ERM actuators consume a lot of power. But when the power-performance ratio is

¹⁹mAh – miliamp hour – measures electric power over time; (the energy capacity of a battery)

considered, piezo actuators are still the best even while not being that power efficient like an LRA.

The following table also represents more energy consumption data for the ERM, LRA, and Piezo-actuator with three different types of haptic feedback

Table 8. Energy Consumption Comparison Data [Source: Texas Instruments]

| Effect | ERM | | | LRA | | | Piezo | | |
|--------|---------------|-------------------|------------------|---------------|-------------------|------------------|---------------|-------------------|------------------|
| | Duration (ms) | Consumption (μAh) | Acceleration (g) | Duration (ms) | Consumption (μAh) | Acceleration (g) | Duration (ms) | Consumption (μAh) | Acceleration (g) |
| Bump | 39 | 1.14 | 0.89 | 40 | 0.3 | 0.93 | 13.3 | 0.31 | 0.96 |
| Click | 50 | 1.72 | 0.9 | 51.3 | 0.57 | 0.903 | 19.61 | 0.34 | 0.921 |
| Alert | 78.7 | 2.0 | 0.96 | 75 | 0.47 | 0.91 | 60 | 1.18 | 0.92 |

According to the manufacturing cost scale, ERMs are the most cost effective. LRAs are becoming more and more popular because of the spring mounted nature of the device. However, the spring constant might change over time and if the actuator is used in a handheld device, due to this reason the resonance can be changed. If the LRA actuator is not driven at the resonant frequency, it may not provide the fully effective range of power savings.

3.3. Voice coil and Solenoid Actuators

The actuation is based on the electrodynamic principle. There is a direct proportionality between the output value (force) and input value (electrical current). Depending on the design, either the coil or magnet is being moved.

The force on which they are based on is the Lorentz force:

$$F_{\text{Lorentz}} = i * l * B \quad (3)$$

The force is apparently dependent on the current i , the magnetic induction B and the length of the conductor l , which is mostly formed as a coil. The actuator is made of the following components:

- Generator of the magnetic field (coil or a permanent magnet)
- Magnetic flux conductor (iron circuit, magnetic core)
- Electrical conductor (formed as a coil or a more complex winding)

Voice coil motors have faster response time compared with ERM actuators [33]. For this reason, they are able to produce single or continuous pulse signals used to simulate button click feedback. Fukumoto and Sugimura integrated a voice coil actuator in a mobile touch screen device and the feedback was perceived by adding a single pulse or a short signal on the user's touching finger.

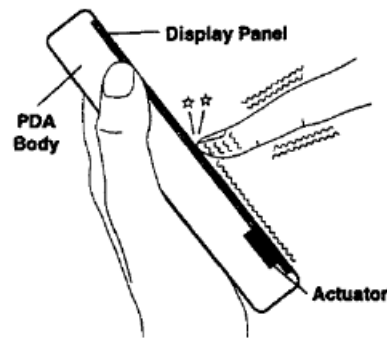

Figure 25. Actuator mounted on the surface of the touch panel [33]

Mentioned previously in [Table 5](#), the difference between voice coil actuators and solenoids is in the vibrating part. In a solenoid, the permanent magnet is being moved, Figure 26.

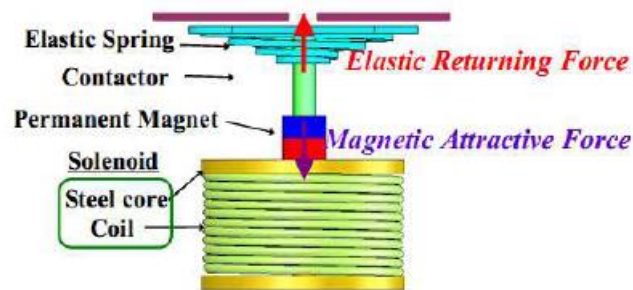

Figure 26. An example of solenoid actuator [33]

Both a solenoid and a piezo actuator can be integrated within the device for generating more complex haptic feedback. The user can feel simulated short feedback owing to the piezo actuator, and at the same time smooth feelings can be created by the solenoid.

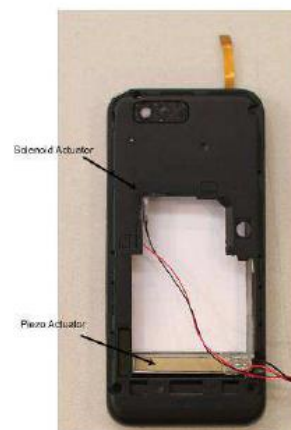

Figure 27. Tactile feedback with both a piezo actuator and solenoid [34]

These actuators are often implemented into stylus-based touch screen displays. For example, a solenoid is often at the end of a haptic pen to generate a wide range of tactile sensations. An important fact is that voice coils are characterized by large power consumption and there might be a certain risk of overheating in some situations. Their size is rather large, which also

indicates medium to heavy weight properties. Though they work with low voltages, the current for activating a solenoid might be high. On the other hand, they provide high acceleration rates which allow confident interaction between the user and device. The solenoid's fast response time in combination with a wide frequency range allows limitless haptic effects. Such actuators should be mounted on springs or other soft materials in automotive applications, because if they were firmly attached all the produced energy would be lost into the dashboard. For example, a solenoid actuator from Johnson Electric²⁰ has already been implemented for creating lateral actuation.

- Lateral Actuation

The actuators in this technology produce a lateral movement (side-to-side) of the surface to produce the haptic effect. The movement is small, just about 0.2-0.3 mm. By stretching the skin of the finger the feedback can be felt. This technology is becoming more and more interesting to manufacturers regarding the strength of effects it can create.

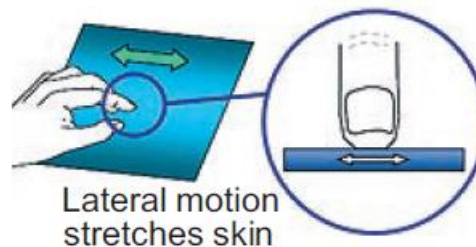

Figure 28. Lateral movement of the surface [Source: Immersion Corp.]

The motion of the touch surface is controlled by a separate mechanism with the actuator providing the only force [3]. Touch screens of 30 inch have been developed successfully so far.

3.4. Electroactive-Polymer-Actuation (EAP)

More and more synthetic materials replace classic materials such as metals in actuator design. Some advantages are cheap material costs and that a variety of shapes can be manufactured with small efforts. Polymers are called “active” if they can change their shape under some circumstances. If there is the influence of light or temperature, they are called non-conductive. If they are actuated by an electrical source, electroactive polymers (EAP) are being considered. When they are used in an actuator, their properties such as elasticity, applicable force, deformation and robustness are comparable to biological muscles.

Depending on the thickness layer of the dielectrics, 1 – 20 kV are typical operation voltages. All EAP technologies are being researched, but two actuator types are used in robotics: “Ionic polymer metal composite” (IPMC) and “dielectric elastomer actuators” (DEA) [35].

The movement is created by applying a charge to electrodes separated by a dielectric polymer film which creates an attraction force causing the polymer film to contract in thickness and expand in area. It is a new addition to haptic interface technologies [36]. This group of

²⁰ <http://www.johnsonelectric.com/>

polymer materials behaves similarly to piezoelectric materials when in touch with an electric field. The difference is a larger displacement than piezoelectric materials, but the main drawback is the need for much higher voltage to produce this movement – about 1000 V. Drivers and methods for handling with this issue exist but the touch sensing function would still require separate electronics. This adds to the complexity and costs of the entire solution [20].

Compared to other technologies, there are not many suppliers on the market. The world's leading supplier and developer of electroactive polymer products is the company Artificial Muscle²¹ and Novasentis²² in USA. However, the biggest challenge for EAP applications in the consumer electronics space is cost. After contacting the Novasentis' Chief Executive Officer Francois Jeanneau, this technology is excluded because manufacturers are not targeting automotive applications at this stage.



Figure 29. Reflex HIC Slide Actuator [Source: Artificial Muscle]

3.5. Surface Actuation

Not unlike the previously mentioned actuators where separate actuators produce the moving force, the mechanism of surface actuation is integrated directly in the touch screen and causes a direct actuation of the surface. Inertial or piezoelectric actuation needs larger or additional actuators when the size of the screen increases, while in case of surface actuation, the actuation mechanism can be incorporated into the touch screen without the need for a separate actuator. This results in a thinnest haptic design available.

This method shows a great promise [3]. Shortly, the operating principle is the existence of electro-attractive force between two surfaces under a charge differential. The system response time is fast and the frequencies are in a 0-500 Hz range. The two conductive materials are charged and separated by a thin layer of air. A dielectric layer is added to manage the voltage difference. By pressing the touch surface, the charged layers pull together. This causes the actuation of the touched layer which can recreate even the feeling of a button press. Springs which are mounted in the corners, support the touch surface, and return it back between actuations. In other words, just the spring elements are moving.

²¹<http://www.artificialmuscle.com>

²² <http://www.novasentis.com/>

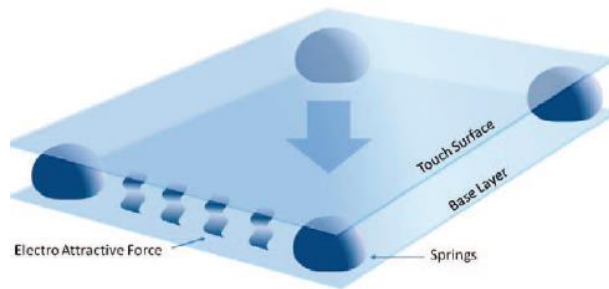

Figure 30. Principle of Surface Actuation [Source: Next System]

3.6. Capacitive Electro Sensory Interface (CEI)

In this technology, the touch surface is not moving, but electrostatic pressure is generated in the skin of the finger. A charge differential is provided that creates a Coulomb force between the electro sensory layer (E-sense layer) implemented between the touch surface and the finger. The force is being changed and modulated in frequencies where the human perception is most sensitive causing actually the skin to vibrate. The nerve endings perform this as a touch feeling. The method can be called simply “electro vibration”.

The properties of electro vibration are different to those of vibro-tactile feedback. The first company which started creating a commercially system solution for handling with electro-vibration in 2007 is Senseg²³ [37]. They integrated the feedback in mobile phones and handheld devices, while in 2009 Disney Research designers implemented the “Tesla Touch” system on experimental desktop-based multi-touch systems. Although there are some implementations of electro-vibration in touch screens, the number of studies including user perception is low. As mentioned before, many studies with vibro-tactile feedback using ERMs and LRAs, show that 250 Hz is the best frequency for users to feel the vibration [37].

The attractive electric Coulomb force between the isolated electrode and user’s finger can be expressed as Maxwell pressure:

$$P = \frac{1}{2} * \epsilon * E^2 \quad (4)$$

where:

ϵ = dielectric constant

E = electric field

$$E = \frac{V}{d} \quad (5)$$

V = voltage difference between electrode and conductive layer of the finger

²³ <http://www.senseg.com/>

d = distance between charges; covers the electrical insulator thickness and finger skin thickness

The mechanism is quadratic with respect to the voltage. This effect doubles the frequency of drive signal, for example, sine waves. Results of a study in Finland show that using 80 Hz voltage sine waves produce the best results. An input signal of 80 Hz creates therefore a 160 Hz Coulomb force vibration at user's finger providing the most intense sensations.

The big difference is that there is no mechanical movement of the device at all. The technology just needs to be built into devices by manufacturers of touch screens. Because of the nature of the technology, there is no limit to the size of screens. The manufacturers actually buy a software programming interface from, for example, Senseg. The interface is created by application developers and eventually adds the different effects to the final product.

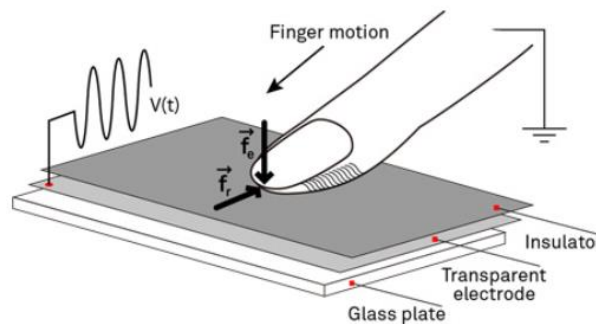

Figure 31. The mechanism of electrovibration [38]

The main disadvantage of the electro-vibration mechanism is that tactile feedback is perceivable only when the user is dragging the finger over the surface. When the user's finger stays on the surface, the induced force is not strong enough to be felt, but when the finger drags the surface, a shear force F_{ef} deforms the skin.

Although the technology is scalable and uniform, it needs high voltage to be applied to the user. Moreover, the electrostatic effect is also affected by skin conditions, e.g. sweating.

4. IDENTIFICATION OF REQUIREMENTS

Without any doubt, haptic systems are mechatronic systems joining actuators, kinematic structures, sensors and control elements as well as complex software [35]. The operation of a haptic control element happens commonly with fingers. Therefore, the characteristic values and parameters in this thesis are restricted to the human hand. They are a result of the skin's sensibility factors and numerous references.

4.1. Demand analysis

It requires a lot of specialist knowledge for the measurement of the operating forces and control of force feedback. In addition, each HMI has individual constraints with respect to space, performance, and usage and cost constraint. Designers should consider:

- **Ease of integration** – size and shape of actuators and drive components, flexibility of options to integrate the components into a device
- **Control flexibility** – how difficult is it to create the waveforms and whether they can be created using a variety of methods to achieve a range of haptic results
- **Cost** – the development and manufacturing cost for the haptic system
- **Performance** – how reliably can the system recreate complex haptic effects (e.g. button-click)
- **Power consumption** – assessing the haptic effect (vibration) strength
- **Technology maturity** – how well market-tested is the technology

After finishing the research part, Table 9 can represent a summary of the haptic actuators which might be considered or excluded at the beginning based on one or more most important facts regarding a button-click effect. The possible methods will then further be evaluated in order to choose the best solution. This will be done in subchapter [4.2.](#) based on the Guideline VDI 2225 (Association of German Engineers) [39].

Table 9. First evaluation of possible actuation methods

| Excluded | Possible |
|--|---|
| <p>Inertial actuator ERM</p> <ul style="list-style-type: none"> • Slow response time; motor has to start spinning • Large energy consumption • Limited in creating advanced waveforms (haptic feedbacks); frequency and amplitude are joined together to the input voltage • Noisy | <p>Inertial actuator LRA</p> <ul style="list-style-type: none"> • Quicker than ERM; immediate movement of the mass as current is applied • Better power consumption than ERM; driven at the resonant frequency • Low profile, often easy to mount • Localized feedback possible, but not common |
| <p>Electroactive Polymers EAP</p> <ul style="list-style-type: none"> • Require high voltages; more than 300V for effects suitable for haptics, mostly 1 kV • Need for separate electronics to handle this problem; adds to complexity and cost • Expensive for mass production • Not that common technology for automotive applications | <p>Piezoelectric actuators</p> <ul style="list-style-type: none"> • Fastest response time • Displacement of the surface (independent of the whole device); localized feedback • Wide bandwidth range • Acceptable power consumption • Strong vibrations; great candidate for bigger screens • Wide bandwidth range; able to generate a variety of waveforms • Thin, low weight; easy to mount |
| <p>Capacitive Electrosensory Interface CEI</p> <ul style="list-style-type: none"> • Just touching the surface is not enough • User has to drag the finger over the surface • Technology more suitable for feedback about roughness/smoothness of the touching surface | <p>Surface actuation</p> <ul style="list-style-type: none"> • Technology independent of the screen size • Also wide bandwidth range and fast response time • Also localized feedback • Easy to integrate; “thinnest” solution |
| <p>Voice coils/Solenoids</p> <ul style="list-style-type: none"> • Large, medium to heavy weight • Driving current requirements might be high • Costly option; no localized feedback | |

After selecting three methods and considering the requirements mentioned before, the following Table can represent a possible comparison.

Table 10. Comparison of three selected methods

| | Inertial LRA | Piezoelectric actuators | Surface actuation |
|---------------------|--------------|-------------------------|-------------------|
| Ease of integration | ■■■ | ■■□ | ■■■ |
| Control flexibility | ■□□ | ■■■ | ■■■ |
| Cost | ■■□ | ■□□ | ■■□ |
| Performance | ■■□ | ■■■ | ■■■ |
| Power consumption | ■□□ | ■■□ | ■■■ |
| Technology maturity | ■■■ | ■■□ | ■□□ |

Comparison of table data might suggest selecting the piezoelectric actuator due to the control flexibility, performance characteristics and low power consumption considering the ability to produce localized feedback. Surface actuation is easy to integrate in any system and does not require additional space in lateral directions, though it is still a new technology which will for sure be more evolved over time and will eventually become more suitable for series production.

The entire requirement analysis includes a few more characteristics besides the previously mentioned. They will all be summarized in the subchapters.

4.1.1. Intensity

Intensity is a characteristic which might be recognized as one of key performance factors. It actually refers to the strength of vibration and is often called amplitude because the amplitude of electrical signals for generating vibro-tactile feedback corresponds to the intensity of feedback. It is easy to control in most hardware applications which makes it perhaps the most frequently used characteristic [40].

Table 11. Intensity

| | |
|-------------------|--|
| LRA | Medium strong vibration; strength limited due to smaller size compared to ERM, though better haptic sharpness |
| Piezo actuator | High fidelity feedback; strong vibrations at low bandwidth,; bending the surface or moving it laterally; precise |
| Surface actuation | High fidelity feedback; strong vibrations; mounted springs are the only moving parts; precise |

4.1.2. Bandwidth

Bandwidth is related to control flexibility which is in turn related to driving signal frequency. It represents the number of achievable vibration cycles occurring over a single second with

negligible attenuation. The perceivable range of vibration frequency is wide. If an actuator disposes of a high frequency, it is able to change position quickly to faithfully deliver haptic effects with high-frequency components, for example, triangular and square waves, impulses and step functions [41].

Table 12. Bandwidth

| | |
|-------------------|--|
| LRA | Frequency fixed within a narrow range (150-200Hz); narrow band over which they have an adequate haptic response; problem might be solved with available drivers with auto-resonance tracking and automatic braking algorithm to prevent ringing at the end of waveforms; amplitude modulation enables unique waveform profiles |
| Piezo actuator | 100-300Hz, wide range allows supporting various haptic applications; amplitude modulation enables unique waveform profiles |
| Surface actuation | 100-500Hz, even wider range |

4.1.3. Power consumption

Power consumption is dependent upon the length of the vibration and was discussed earlier in [Chapter 3](#) when piezoelectric actuators were compared to inertial actuators. It is again mentioned here because it is an unavoidable requirement. The following table stresses the main facts for the three selected technologies.

Table 13. Power consumption

| | |
|-------------------|--|
| LRA | Very power efficient; driven at the resonant frequency |
| Piezo actuator | Less power efficient than LRA, but comparable with most LRA motors |
| Surface actuation | Also power efficient; less than 10 mW for most configurations |

4.1.4. Response time

As with power consumption, response time is a requirement which was discussed in the previous chapter, but it nevertheless needs to be discussed again. It answers the question how quickly an actuator can produce a certain effect. It is often claimed that the piezoelectric actuators have the fastest response time compared to inertial actuators. This might be the final requirement for selecting an actuator which can create the button-click effect because the dynamics is less than 1 ms. However, the surface actuation technology has a fast response time as well. The surface response is virtually immediate.

4.1.5. Mounting

This requirement is related to ease of integration and the form factor (size/shape/weight). How complex is the installation procedure and what are the connection solutions? Is there a need for rigid connections, should screws, clamps or some adhesive material be used, etc. If adhesive might be a solution, it could reduce tolerance in assembling and manufacturing processes. This solution might reduce unwanted vibrations, and, in case of piezoelectric actuators, the piezo material could be replaced much easier. In general, a lower-mass moving element can be driven at higher frequencies, and produces less inertial counter-motion of the housing or end product, reducing mechanical and acoustic damping needs [41].

Table 14. Mounting

| | |
|-------------------|---|
| LRA | Small to medium; cylindrical and rectangular; low to medium weight Easy installation due to adhesive backing |
| Piezo actuator | Thin; rectangular or other shapes; low weight: 0.5-3mm Easy installation, adhesive might be used |
| Surface actuation | Thinnest solution; Easy installation: though some additional space required for active layers-increase in thickness is less than 0.5mm over standard touch screens |

4.1.6. Drive voltage

The drive voltage for LRA actuators is the lowest, approximately 10 V but the current might be high. On the other hand, piezo actuators need to be driven at up to 200V. Therefore, the use of multilayer piezo actuators can reduce the required voltage. The surface actuation technology also needs higher voltages than other solutions and there is a legitimate concern regarding the risk for the user in a crash situation, considering that the display works by the electrostatic principle. The developers claim that there is no risk, but, of course these screens need to be integrated appropriate in vehicles.

4.1.7. Audible noise

The last requirement, but not less important is the noise which actuator technologies produce. LRA are maybe less noisy than an ERM actuator but still not silent as a piezo stripe. Piezo actuators do not have a moving mass, which is equivalent to usage of the surface actuation technology.

4.2. Selection of the actuator

Considering the desired haptic effect similar to a button-click and taking into account the above mentioned requirements, a detailed assessment scheme is given herein. For the application of this scheme, the requirements are used as a basis for the suitable assessment criteria and are graded according to Table 15 (based on the Norm VDI 2225) [42]. The

priorities of the individual assessment criteria are also taken into account by using a suitable priority factor (see Table 16).

Table 15. Rating scale VDI 2225

| Assessment | Points |
|-------------------|---------------|
| Ideal | 4 |
| Good | 3 |
| Sufficient | 2 |
| Barely Acceptable | 1 |
| Unsatisfactory | 0 |

Table 16. Priority table

| Priority | Factor |
|-----------------|---------------|
| Very important | 4 |
| Important | 3 |
| Less important | 2 |
| Not important | 1 |

Based on the above tables, the assessment criteria can be summarized within a single table in order to facilitate a convenient overview of actuator features and, thus, to simplify the selection of the most favorable actuator (“best choice”). The contribution of each criterion is included by multiplying it with the assigned priority number for the considered requirement, and these contributions are then summarized for each actuator in order to provide the overall actuator performance grade.

Table 17. Selection of the actuator

| Assessment criteria | Priority | LRA | Piezo | Surface Actuation | Ideal |
|---------------------------|----------|-----------|-----------|-------------------|------------|
| Intensity | 4 | 2 | 4 | 4 | 4 |
| Bandwidth | 4 | 1 | 3 | 4 | 4 |
| Power consumption | 3 | 4 | 4 | 3 | 4 |
| Response time | 4 | 3 | 4 | 4 | 4 |
| Mounting | 3 | 3 | 4 | 4 | 4 |
| Drive voltage | 3 | 4 | 3 | 2 | 4 |
| Audible noise | 3 | 3 | 4 | 4 | 4 |
| Sum | | 66 | 89 | 87 | 96 |
| Percent% (rounded) | | 69 | 93 | 91 | 100 |

The result of the above demand analysis indicates that piezoelectric actuator is apparently the most appropriate solution for the particular implementation. Namely, piezoelectric actuator has scored a notably higher rating compared to the LRA actuator, whereas the surface actuation is a technology which is typically integrated directly into devices (after detailed consultation with the costumer). After consultations with contact person Karl Bayer from *Next System* (surface actuation system manufacturers), these types of actuators are apparently very likely to become a much more commonly utilized technology in the future. Note however, that even though it scored similarly to the piezoelectric actuator, the main inherent drawback of these actuators is their higher required operational voltage.

4.3. Kyocera Piezoelectric actuator

Following the selection of the most appropriate actuator, the next step has involved looking for companies and experts who have had experience with integration of such actuators within HMI devices. Market research has shown that the Japanese multinational electronics and ceramics manufacturer Kyocera²⁴ has already developed a haptic feedback device comprising piezoelectric actuators, so-called *Haptivity* device, and a prototype which indeed simulates a button-click effect on a touch screen is already available for purchase. Fortunately, the office for LCDs and touch solutions is located in Germany, which made their procurement relatively uncomplicated. Dr. Matthias Neundorf invited us and an appointment was arranged to try out the prototype and feedback generated by their piezoelectric actuators. A cooperation agreement was signed because both companies can benefit if the existing solution could be improved through prototype design and field testing.

²⁴ http://www.kyocera.eu/index/products/lcds_glass_glass_touch_panels.html

Kyocera integrated the multi-stack piezoelectric actuator within a metal shim plate which enables the actuator to increase the generated force. In particular, two small elastomer elements have been attached, as well as one elastomer in the center of the opposite side (see Fig. 33). These elastomers are actually support elements and serve as damping material because the actuator is pushed away from a suitable mounting support, which is in fact a 3-D printed silicone-based support element, and it works pretty well for the prototype requirements and demonstration purposes. However, this is not a suitable solution which can be implemented in production devices. Four additional damping elements in the form of specialized foam material have also been used in the four corners of the prototype device in order to prevent damage to the touch screen. In this particular demonstration implementation, the space between the display and touch screen is left open, so dust and moisture can accumulate, and, consequently, may affect the device operation.

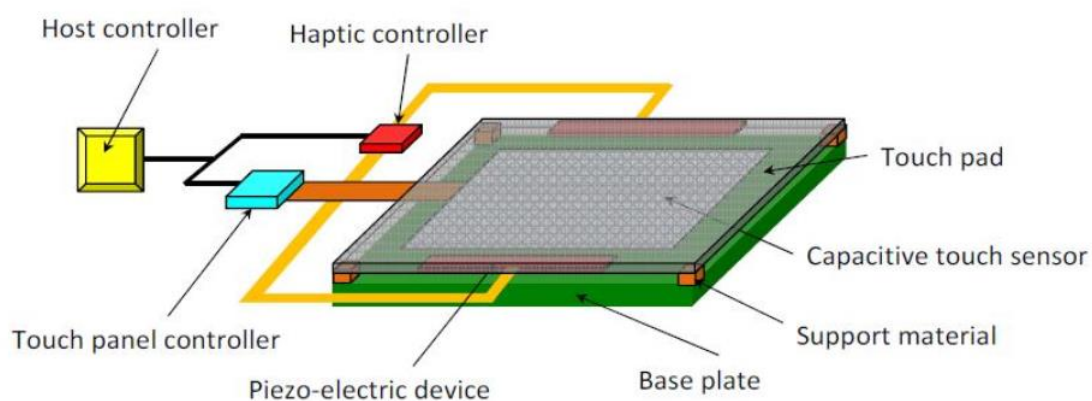

Figure 32. Principle design of an HMI based on piezoelectric actuators [30]

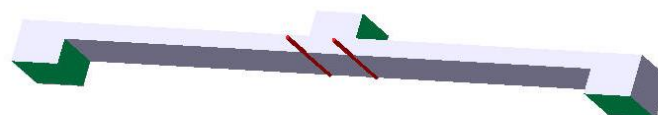

Figure 33. CAD model of the Kyocera Piezoelectric actuator

The green blocks in Fig. 33 represent the elastomer elements and the red parts the connection cables. The thin piezo stripe is glued on the lower side of the main metal element. The piezo ceramic crystal is coated with silver and glued on the lower side of the stainless steel element. The model in Figure 33 is the so-called shim plate which is integrated into the respective mounting support. The whole “unit” is screwed onto the display’s backlight on both sides and when the user presses the touch screen with a certain force, the piezo ceramics element first acts as a sensor and detects the force. Then it plays the role of an actuator and, by means of bending, the actuator pushes together with the support element against the touchscreen. The user perceives this event in nearly the same way as if a mechanical button has been pressed (i.e. near instantaneous action can be obtained due to wide bandwidth of the piezo element).

Owing to the cooperation with Kyocera, it has been demonstrated that the desired feedback can indeed be achieved in practice with piezoelectric actuators. The next task in this R&D work is to improve the existing prototype by creating a new and improved mounting support element which requires less space. Further, the sealing problem has to be solved and the vibration/shock damping conditions must not be ignored. From the available literature and engineering experience, a number of feasible solutions can be found to suit the application at hand, starting from a holder which is also a sealing and/or damping element etc. The material of the mounting support element, as well as the material of the surface area which is being pressed also needs to be considered. Questions such as whether to use a display unit separated from the touch screen or just go for a simple solution with a glass/plastic plate without backlight are all discussed in the next chapter.

5. METHODOLOGICAL CONCEPT DEVELOPMENT

As mentioned above, the existing form of the Kyocera mounting support element requires some improvement. Since, in actually, mounting support element represents a holder for the actuator; the more generic term “holder” will be used from now on. From the beginning of the concept development phase, one of the main requirements has been the straightforwardness of the solution. Actually, the very first concepts were more complicated because, except the holder, they included other components such as the entire housing. The focus is put herein on the design of a holder which must be connected properly to the touch surface in a way which allows the upper plate to move so the feedback can still be felt. Kyocera engineers claim that the glass cover displacement magnitude is about 40 μm . On the other hand, the sealing and damping problems must definitely not be ignored in each concept.

5.1. Requirements

In order to design a valid prototype for testing the selected haptic actuator, the requirements which need to be taken into consideration differ from those made during the actuator selection. The most important requirements are listed in the following table:

Table 18. Requirements on the prototype design

| Requirement | Remark |
|--|--|
| Sealing | To prevent sealing problems between the front plate and display module (dust, moisture...) |
| Damping | To provide damping conditions due to the vibration of the front plate |
| Display's active area | Not to influence the active area with the holder or other components |
| Actuator mounting | Suitable fastening of the actuator is needed to produce a satisfactory feedback |
| Front plate's material | Selection between glass or plastic regarding thermal expansion, gluing properties etc. |
| Front plate's thickness | Suitable thickness for automotive displays |
| Distance between front plate and display | It is highly important to avoid the <i>Parallax</i> problem related to viewing angle |
| Front plate mounting | In case of optical bonding, the following features need to be considered: <ul style="list-style-type: none"> • Viscosity of the adhesive • Thickness of the applied adhesive layer • Prevention of leaking out when applying the adhesive |

- Sealing material and damping conditions
 - Foam

Display dust seals are the most basic requirements in these applications. The edge of the viewing area has to be sealed (See Fig. 34), and sealing is often achieved by sponge materials or foams such as Poron Urethane [43]. Manufacturers offer recommendations on adhesive strength and material type. However, factors such as stress relaxation, compression settling, sealing performance, cost and manufacturability also need to be considered in the analysis. With or without haptic feedback, the housing which holds the display in place can exert pressure upon the display. For this reason, suitable foam materials can also help cushion the touch screen/display assembly from shock and vibration.

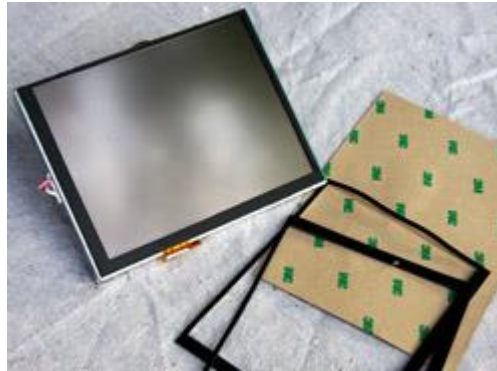

Figure 34. Poron Urethane Foam [Source: Stockwell Elastomerics]

The thickness depends on the level of sealing required and the designed air gap in the housing. Most touch screen sealing components are thin and soft, but can be made larger with the display size. Poron foams are designed for electronics applications; therefore there are many standard thickness and firmness options available. The space between display and touch screen should not be greater than 0.5mm to achieve optimal viewing conditions [44].

- Optical Bonding

Even though the use of Poron foam might be a very simple and, above all, a cheap solution, the latest display technology is using the optical bonding procedure. For instance, displays behind a protective glass are difficult to read in direct sunlight [45]. The best solution is bonding the glass cover directly to the display using a transparent adhesive. Such adhesives are often cured by UV light or by a combination of light and humidity in case of shadowed areas (glass with blackprint). The company DELO²⁵ develops products in the field of polymer chemistry with the focus on industrial adhesives and curing lamps. Their products are used in electronics, metal, glass and plastic processing.

²⁵ <https://www.delo-adhesives.com/en/applications/optical-bonding/>

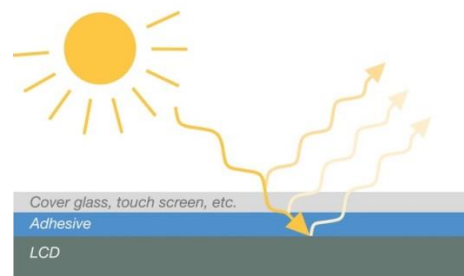

Figure 35. Optical Bonding Material [Source: DELO]

Some of the advantages of optical bonding include:

- No internal reflections
- No condensation or fogging
- No air gap (thus preventing dust entering the display unit)
- Improved vibration resistance
- Reduced danger of splintering in case of glass breakage

Filling the gap between display and cover glass drastically reduces internal reflections. The products combine excellent adhesive properties with high transparency, while the bonding layer improves the readability of the display in bright surroundings and provides humidity and condensation resistance. Moreover, the material is very flexible and allows bonding directly on the display, and the bonded display is more stable and more resistant to mechanical stress. The shock resistance was demonstrated by drop ball tests.

Although optical bonding might increase the cost in the prototype design, it is a desired feature which leaves a good impression. For this reason, the haptic feedback by a piezoelectric actuator will firstly be tested on a bonded front plate. It is important that the bonding material is soft enough and the front plate is not rigidly connected to the housing.

The company 3M²⁶ has also been contacted, because, among other reasons, 80% of all monitors worldwide are covered with their polarizer filters and they have their own optical clear adhesives as well. Their products are not Optical Liquid Adhesives (OCAs) but Contrast Enhancement Films (CEFs). They suggested separating the backlight unit from the touch screen which would not require a soft adhesive. However, this could again lead to the root problem, because Kyocera's prototype was designed in this way.

Before the decision about using soft optical bonding material was made, some concepts had been developed with a foam sealing element. Therefore, all ideas with or without bonding material will be shown in this work.

- Display's active area

²⁶ http://solutions.3m.com/wps/portal/3M/en_US/NA_Optical/Systems/

The active area of a display is the one with active segments in horizontal(x) and vertical(y) direction. This is the largest rectangular image that a monitor is capable of displaying as a viewed image.

While developing different concepts, some holders were designed in a way that a part of the holder covers the edge of the front glass. In those concepts, this part must not be too wide to avoid affecting the displayed image.

- Actuator mounting

In the concept development phase, different ways of mounting the actuator were considered. Actually, this included the options of mounting the holder together with the actuator as well. It has to be evaluated whether to place the actuator between the front plate and display (which can lead to more space in between) or place the actuator laterally upon the holder. Gluing or screwing some components also influences the entire prototype solution.

- Front plate's material and thickness

Since optical bonding is preferred due to the advantages in terms of clarity, it is important to study the technical documentation of different adhesive products. Namely, not all adhesives are applicable because gluing technique depends on the application and materials being glued. It is typically considered that bonding glass to glass is simpler than bonding glass to plastics [46]. However, most of today's displays have a plastic polarizer film on top of the glass, so an appropriate bonding material has to be chosen. Some of the requirements on the adhesive are low viscosity and, of course, more than 99% transparency. It is desirable that the cover plate of the prototype is made of glass because it is preferred in the automotive industry due to its scratch resistance. Further, the usual thickness of these glass plates is approximately 1 mm.

- Distance between front plate and display

This problem can occur if the air gap between the display and cover glass is not filled with an optical bonding layer and, instead, too thick sealing elements are used. According to the manufacturer Newhaven Display International²⁷ [44], and their applications engineer Saurabh Baxi, the thickness of the sealing element should be in the range of 0.2 mm to 0.5 mm in order to obtain optimal viewing conditions. Otherwise, the *Parallax* issue can occur (Fig. 36). It is a displacement in position of an object viewed along two different lines of sight. It is measured by the angle of disposition between those two lines [39]. The main consequence is that the user can touch the wrong area while trying to touch a certain button.

This can be a huge problem especially in touch screens. It is easy to imagine this issue while standing in front of an ATM – a cash machine. ATMs have very thick protective cover glasses which causes a long distance to the display. Looking at the touch screen from a slightly different angle leads to this effect.

²⁷ <http://www.newhavendisplay.com/>

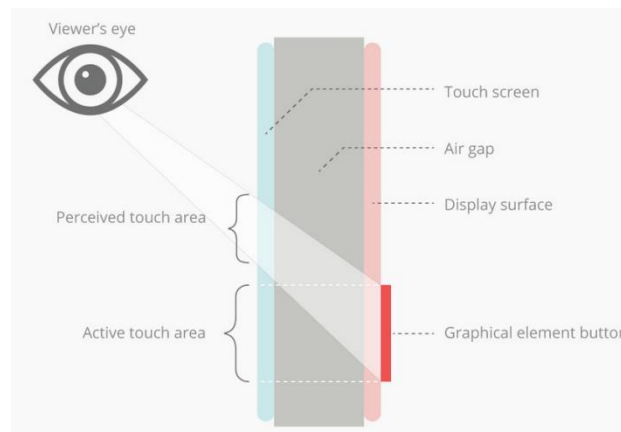

Figure 36.Parallax issue [47]

The issue disappears if the air gap is small like in mobile phones and when the display or cover glass is very thin. If there is no need for an additional glass over the LCD unit, the problem is effectively avoided.

- Front plate mounting

Different concepts include different mounting options of the chosen front plate. There must not be a rigid connection because it has to be displaced in a $40\ \mu\text{m}$ range by the actuator. Further, if the holder is firmly glued to the glass, the use of additional Poron foam might be considered, or other mounting options may be taken into account.

5.2. Concept synthesis

In the first stages of designing a technical product, using a guideline might be recommended [48]. A guideline proposes a general methodology for designing technical products and supports a systematic design in order to produce an efficient working style. A sufficient amount of technical literature and patent specifications should be studied and technical/economic shortcomings of previous solutions should be worked out. All technological experiences and possibilities that intuitively appear to be a solution should be identified, while, if possible, solutions which seem to be absurd can immediately be discarded.

The basic principle is to determine the main task. It is followed by the working principle where possible assembly elements are combined together. Disadvantages of those solutions should be reduced and the solutions with least shortcomings should be established. One of the main aspects is the application of CAD²⁸ for the concepts. Firstly, all of the 3D models and assemblies are designed in a very simplified manner, and often oversized, in order to present the idea in the software CATIA V5. Later on, when the final concept has been chosen, it was redesigned with all details and real dimensions that enabled the assembly of the prototype.

The concepts are explained in the following subchapters and labeled with Roman numerals. The different variants are then marked with capital letters of the Latin alphabet. The figures of

²⁸ Computer Aided Design

different concept variants are shown in tables and marked with numbers. In all of the following concepts, the backlight and LCD glass are one unit, while the cover glass is always being separated from the rest of the system.

- Structure of LCD panel

In order to further illustrate the aforementioned LCD separation issue, the LCD structure is shown in the following figure and a short explanation is given.

The structure basis is the backlight system which underlies the entire display and produces the light we see on the screen. A backlight with its components can be seen in [Appendix III](#). This unpolarized light travels through a polarizing filter, hits a film of liquid crystals, goes through a color filter (which turns the white light into the RGB²⁹ color-space), which is subsequently transmitted to the second polarizer film and finally exits the screen where it meets the human eye.

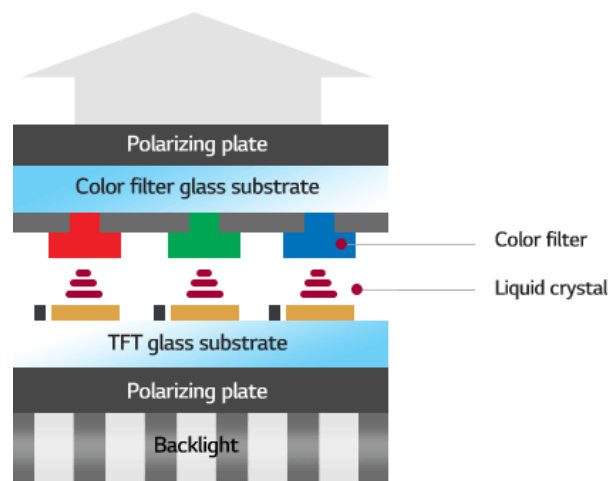

Figure 37. LCD structure [Source: LG]

The liquid crystal film within the LCD unit is sandwiched between two glass substrates which house the transparent electrodes and circuitry required for display operation. The contact person from Kyocera has said that the approximate thickness of those glass substrates is 0.7 mm. This means that the whole LCD has a thickness of 1.4 mm, which is still extremely thin.

5.2.1. Concept I–Piezo between display unit and front plate

A simple holder was designed which can be modified in various ways. Even though different variants of the first concept will be presented, these variants have one thing in common – the piezo module is inserted between the display and glass plate, wherein the holder has a side-slip upon which the actuator can be placed. In other variants the holder can have two side-slips wherein one of those goes beneath the display unit. Moreover, a third side-slip can be placed over the cover glass and serve as part of the housing. Furthermore, the holder can either be as long as the piezo module, or in other variants have the same length as the

²⁹Red-green-blue (an additive color model)

display unit. Figure 38 shows the front view of a very simple holder with one side-slip for the actuator.



Figure 38. Concept I – First option of the holder

- Concept I – A

The first variant consists of a simple holder (yellow) within the display's length with one side-slip for the piezo actuator, as shown by Figure 39. The holder is attached from the side to the display unit (black) with metal frame (dark grey), and can be subsequently screwed onto the housing from the side. This housing can, as is commonly done, be screwed onto the display from the bottom. The actuator can be glued from the bottom or be held through a form-fitting connection within the holder (1). The glass plate is attached to the upper side of the actuator module and holder (2). Thin foam (3) is glued to the glass before the upper cover (4) is placed on top of it. This enables the glass plate to move because it must not be rigidly connected within the entire system. Everything is enclosed by a housing to which the upper cover can be connected by screws (5). This represents a solution in which all the components are held in place, while the glass can still be moved by the actuator's force.

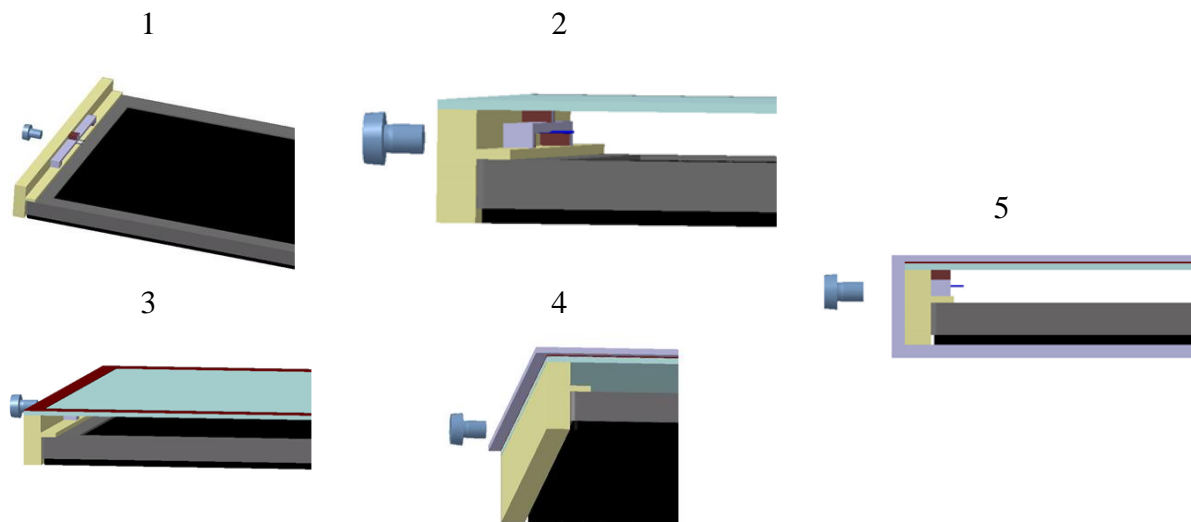

Figure 39. Concept I - Option A

○ Concept I – B

A similar solution is shown in Figure 40. The main difference is in the additional foam element between the display and the holder and the length of the holder itself, which is now shorter. This second foam element is optional and can serve as a damping element for the display, which is prone to vibrations created by the actuator placed upon the holder. The holder also has another side-slip going beneath the display, which can change the mounting options of the entire system. In this solution there is no need for side screw connections. The display can be fastened by screws from the bottom through the housing and holder. The housing in the following variants is designed just from one side for representation purpose.



Figure 40. Concept I - Option B

- Concept I – C

The main disadvantage of the first two variants is the air gap between the display unit and front glass. The actuator's height is 4 mm and even with a 1 mm thick side-slip, the air gap should be closed and, if possible, reduced. After careful consideration, the solution has been found in the form of a foam element being placed next to the actuator, having a thickness which just fills the gap. See 8 and 9 in Figure 41.

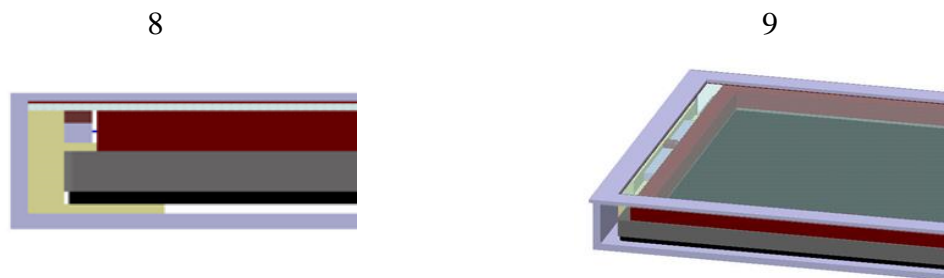

Figure 41. Concept I - Option C

- Concept I –D

For an easier building of the prototype, a third side-slip can be used so the entire holder plays the role of the housing. The third side-slip goes over the cover glass, while the rest of the design stays as shown in variant C of the first concept. The glass layer in the fourth variant has the same size as the display and is placed upon the actuator. Of course, the holder can be extended in the display's length and not just in the actuator's length. Figure 42 presents the main idea of the proposed concept.



Figure 42. Concept I – Option D

It is important to stress out that the holder in each variant of the first concept may require holes (openings) for the actuator's control elements. This, and many other details, will later be taken in consideration when it comes to the production of the holder, whether on the milling machine or on the 3D printer.

The mounting option of the actuator has already been discussed. It can either be glued on the holder or, if a milling machine is used in the production process, holes can be easily drilled in the holder. Then the actuator is held through a form-fitting connection.

With the fourth presented variant (variant D), the satisfactory sealing is achieved and no dust can penetrate into the space between the display and cover glass. Hence, environmental

influences cannot affect the required and desired clarity of the transparent layer. The glass is held by the holder and can move owing to the upper foam element.

However, further concepts need to be considered in order to reduce the huge air gap between the display and front glass. Air gaps of approximately 0.5mm can be allowed without getting condensation and humidity problems [44]. This was confirmed by a contact person from the American display manufacturer Newhavendisplay.

Therefore, a second concept has to be introduced in which the actuator is mounted from the outside of the system and not between the display and glass.

5.2.2. Concept II – Piezo on holder laterally

In the second concept the holder is designed so that it is always attached from the side to the mounted actuator. The space between the display and cover glass is thus reduced. Instead of a 4 to 5 mm broad air gap, the distance can be set to, for instance, 1 mm (or less).

○ Concept II – A

It can be seen from the first variant shown in Fig. 43 that the air gap is noticeably reduced. However, an important question is whether the actuator can transmit enough force to the cover plate through the holder if it is mounted as shown in this variant (See Fig. 43).

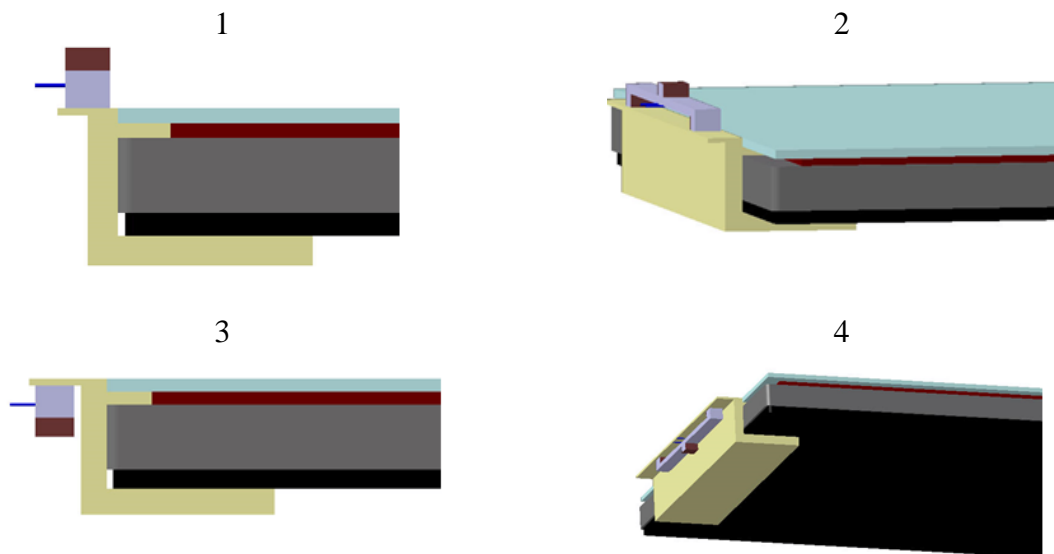

Figure 43. Concept II - Option A

It might be worth a try to find the answer to this question. Another important question would be whether it is better to mount the actuator on the upper side of the holder or, alternatively, to glue it from the underside. In case of gluing it from the underside, the side-slip should be extended for at least 1.5 mm (See Fig. 43). Hence, an additional solution for mounting the glass plate should be found. On the other hand, mounting the actuator on the upper side could make it more difficult to attach the prototype to some kind of housing.

Without producing the holder and building a prototype in this way, these questions are difficult to answer, which makes this kind of solution somewhat impractical. Therefore, another variant of the concept was considered instead.

- Concept II – B

The idea herein was to use an even simpler holder which just goes over the cover plate with the side-slip. The actuator can again be mounted from both sides of the holder. The only component which comes between the display and cover plate is the foam sealing element. The production of the holder would thus be easier and there would be no issues regarding the air gap. For that purpose, Poron foams are available in very small thicknesses.

It also seems more logical to attach the actuator from the upper side on the holder, but this requires more space for the integration/assembly of the entire system later on.

The second variant does have some advantages over the first variant in the second concept, but it still does not seem to be a comprehensive solution. Could the holder transmit the actuator's generated force is too questionable. A combination where the air gap is reduced by mounting the actuator directly under the cover plate is considered next.

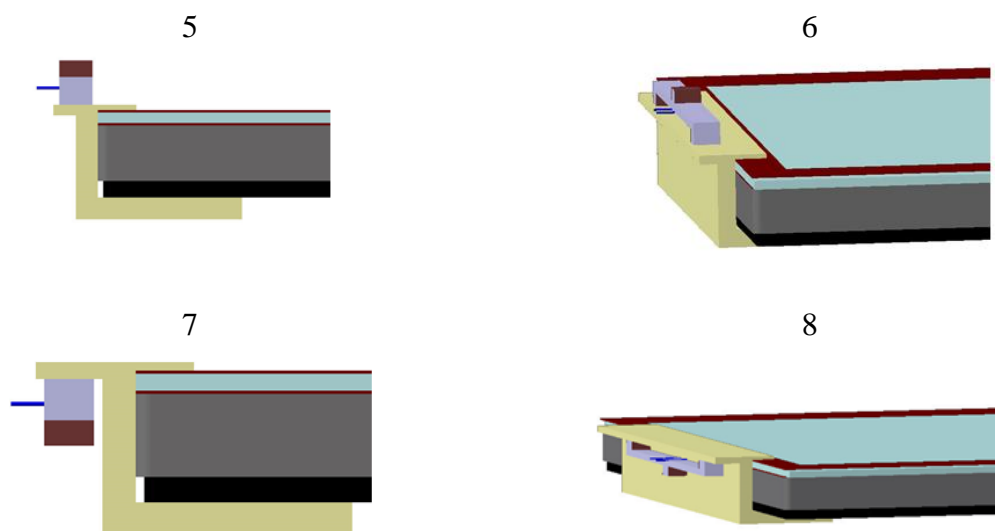

Figure 44. Concept II - Option B

Before showing the third concept which is much closer to a convenient solution, the third variant of Concept II will be presented. Even the idea of modifying the Kyocera's metal shim plate and placing the third elastomer element differently, was considered in this approach.

- Concept II – C

As shown in Fig. 45, the holder (9) can have a simple profile with a hole in the center for the 1 mm thin metal plate (10) to pass through (11). The third elastomer element could be glued onto this extended part of the metal plate, while simultaneously having direct contact with the glass plate.

The third option is more promising compared to the first two in terms of functionality. Despite this fact, the problem of huge air gap is still present. The height of the elastomer element with the metal plate is 2.5 mm, which also requires a foam element with this thickness and results in an unwanted air gap in comparison to the second variant.

So far, each concept has its own advantages and disadvantages. Ideas for the third and fourth concept, and finally, for the fifth concept were developed after which a selection had to be made.

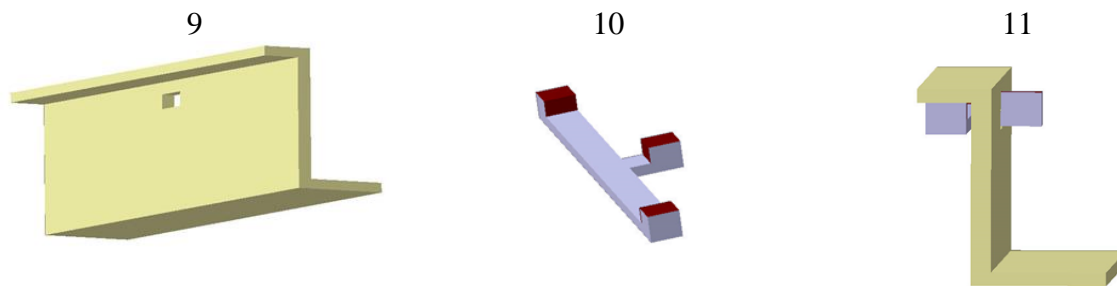

Figure 45. Concept II – Option C

The entire second concept was presented without thinking too much about the mounting options of the cover glass. It can either be glued, as suggested in the first variant, or screwed to the holder, as shown in the second variant. If screws are used, a small damping element has to be attached beneath the screw head. The third option would require even an additional housing for keeping the glass in place. These are all factors which need to be considered, but at the same time allowing the actuator to move the plate.

5.2.3. Concept III – Piezo inside the holder

The third concept has shown more promise than the first two concepts because it is foreseen that the actuator “sits” inside the holder, still being laterally mounted. Due to this holder profile, the distance between the glass plate and display unit can be set arbitrary. The most important characteristic of this concept is that the cover glass is wider than the display unit. It is true that more space is required laterally, but this can be covered without influencing the display’s active area. The very first version for this concept was still planned with a foam element, while the other options included the use of optical bonding adhesive. This introduces now fixing options for the cover glass. The concepts have shown progressive improvement.

○ Concept III – A

The proposed solution started with a holder with two different heights. One surface is planned for attaching the actuator onto it, while the other surface is in contact with the glass plate from the outer side.



Figure 46. Concept III - Option A

In Fig. 46, the foam (red) is 0.5 mm thick. By changing the height of the both surfaces of the holder, the distance from the display to the glass plate can be adjusted. For example, by decreasing the height of the holder for 0.3 mm, a 0.2 mm air gap is facilitated, which is even more acceptable because the [Parallax](#) problem can still be avoided with such narrow air gaps.

One problem (i.e. of Parallax) might apparently be solved, but still another problem remains. How to fasten the glass plate? In particular, is screwing or gluing the glass to the upper part of the holder a favorable approach regarding the haptic feedback?

○ Concept III - B

To be on the safe side considering the above questions, the holder can be designed so that it covers the glass. Similar to one of the previous concepts, it could play the role of the housing.

The idea is shown in the Fig. 47. The first foam element (dark red) serves as a sealing element for the display unit and the second, thinner foam element (light brown) allows the glass plate to move.



Figure 47. Concept III - Option B

As seen above, the concept development phase is apparently a process in which one question follows the other. If the holder can replace the display housing for the prototype purpose, can it be mounted before or after mounting the glass plate? If it is mounted before, can the glass plate in reality just be pushed in? If it is mounted after; can the glass plate just sit on the foam element before being attached to the holder?

- Concept III - C

Using the optical bonding technology was a decision made at exactly this point of the concept development phase. As shown in Fig. 48, the liquid adhesive (white) holds the glass plate and there is no need for any housing elements and issues regarding the mounting options of the glass are effectively avoided. The problem of having an air gap is also solved in this way. Since the layer of the bonding material is very thin, this also has all additional advantages mentioned before, starting from reduced light reflection and so on. The first idea which included all these assumptions is shown in (5) and (6) of the third concept (Fig. 48). Actually, this idea came from replacing the foam element from the first option with the adhesive material. This is why the two options look quite similar. The real adhesive layer is even thinner than it is presented in Fig. 48.

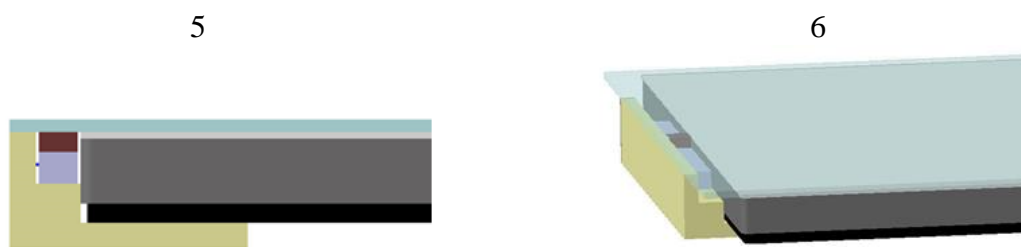

Figure 48. Concept III - Option C

One modification of an existing concept leads often to another. The solution shown in the third option has many advantages over the previous concepts. However, additional solutions need to be considered in order to prevent the liquid adhesive to come in touch with the actuator. This resulted in the fourth concept which consists of two options.

5.2.4. Concept IV – Piezo element separated from the adhesive

The two options in the fourth concept include a holder which does not allow the adhesive to spread upon the actuator (Fig. 49). The presented concepts only differ in the thickness of the holder and in the possibility whether to close the actuator from both sides or not.



Figure 49. Concept IV

The thickness of the applied adhesive can later be discussed. Because these adhesives are mostly cured with UV light, they cannot be thicker than 4 mm. In the prototype design, there is no need to have a layer thicker than 0.5 - 1 mm at all, and it can even be made thinner. A thin foam element might not be necessary because the adhesive provides certain flexibility.

It can be seen in Fig. 49 that the difference is in the thickness of the holder. In the first option (option A) the actuator is not completely enclosed within the housing as in case of the second option (option B). This would not require additional holes in the holder for the actuators' control elements; although in this particular arrangement securing apertures for control elements does not present an additional complication in the production process. On the other hand, the design of the holder in the second option has two separate surfaces in contact with the glass plate. The right side prevents leaking out of the adhesive, while the optional left side can serve as an additional support surface for the glass.

5.3. Evaluation criteria

The concept elaboration and selection is also an important part of such a project. These four concepts with different options show that finding an appropriate concept is not an easy procedure. Generally speaking, the process starts with one idea which, more commonly than

not, has some distinct disadvantages. Other possible alternatives occur while looking for improvements. In the end improved concepts are actually a combination of previous ideas.

The decision cannot be made just because someone prefers one concept over another. For this reason, the rating scale and priority table which were used to select the haptic actuator were used again for the final concept selection as well. Because there are different combinations, the subsequent selection table can give an applicable overall view of the most favorable solutions.

The assessment criteria slightly differ from the requirements referring to an entire automotive display unit prototype. The damping action is provided for by using the sealing element, whether with foam or a soft adhesive layer, so this requirement will not be considered herein. The front plate's material can be some kind of plastics, but automotive displays mostly have real glass cover plates which are approximately 1mm thick. The DELO's contact person Ralf Hose claims that glass is easier to bond with optical clear adhesives and also has advantages in the haptic feedback technology. Therefore, the use of glass is assumed in the concept evaluation.

The aforementioned concepts are evaluated according to the following requirements:

- **Sealing conditions** - Could dust enter the space between display and cover glass?
- **Display's active area** – Could the concept significantly affect the display's active area (i.e. the holder itself or even a holder with a sealing foam element beside it)?
- **Air gap** – Can the Parallax issue occur?
- **Suitable mounted front plate** – Is the front plate mounted too stiffly which disables the movement or is it not fixed appropriately for assuring the feedback?
- **Suitable mounted actuator** – Is it attached beneath the glass plate which is mostly desirable or is it attached to the holder which has to transmit the force?
- **Holder's required integration space** – How much space (i.e. mostly laterally) does the entire concept require when being eventually installed within a vehicle?

5.4. Concept selection

Firstly, all options from each concept were rated. After this, the most applicable solutions were included in a final table and the concept was selected. Altogether, 12 combinations will be presented.

5.4.1. Generation of selection tables

- Concept I - Piezo between display unit and front plate

Table 19. Concept I – selection

| Assessment criteria | Priority | A | B | C | D | Ideal |
|-------------------------------------|----------|----|----|----|-----------|-------|
| Sealing conditions | 4 | 0 | 0 | 4 | 4 | 4 |
| Affecting Display's active area | 4 | 3 | 3 | 2 | 2 | 4 |
| Small air gap | 4 | 0 | 0 | 0 | 0 | 4 |
| Suitably mounted front plate | 4 | 3 | 3 | 3 | 3 | 4 |
| Suitable actuator's position | 4 | 4 | 4 | 4 | 4 | 4 |
| Holder's required integration space | 3 | 3 | 2 | 2 | 4 | 4 |
| Sum | | 49 | 46 | 62 | 68 | 92 |
| Percent % (rounded) | | 53 | 50 | 67 | 74 | 100 |

The first two variants of the first concept, *A* and *B*, got the lowest number of points due to the huge air gap between the display and glass plate where dust can enter. The actuator is placed beneath the glass plate which was a good idea in itself (at the beginning of the design selection), but the sealing problem remained even in this case. This is solved in the variants *C* and *D*.

Considering the integration space, option *D* got more points because the holder can also serve as housing and fewer elements are necessary for a prototype design. There is also the possibility that the holder would be later designed in a way that it surrounds the entire display unit which could make the integration process into the vehicle even easier.

- Concept II - Piezo on holder laterally

Table 20. Concept II – selection

| Assessment criteria | Priority | A | B | C | Ideal |
|-------------------------------------|-----------------|----------|-----------|----------|--------------|
| Sealing conditions | 4 | 4 | 4 | 4 | 4 |
| Affecting Display's active area | 4 | 2 | 3 | 2 | 4 |
| Small air gap | 4 | 3 | 4 | 0 | 4 |
| Suitably mounted front plate | 4 | 2 | 3 | 2 | 4 |
| Suitable actuator's position | 4 | 2 | 2 | 3 | 4 |
| Holder's required integration space | 3 | 2 | 3 | 2 | 4 |
| Sum | | 58 | 73 | 50 | 92 |
| Percent % (rounded) | | 63 | 79 | 54 | 100 |

In the second concept, the variant *B* is the most appropriate because it does not considerably affect the display's active area. There is no need to place an additional sealing element next to the side-slip. The holder can effectively replace the dedicated housing, which has not been the case in the variants *A* and *C*. Despite attaching the actuator directly beneath the glass plate in the third variant (variant *C*), it again results in increased air gap, which is penalized accordingly.

- Concept III – Piezo inside the holder

Table 21. Concept III - selection

| Assessment criteria | Priority | A | B | C | Ideal |
|-------------------------------------|----------|----|----|------------|-------|
| Sealing conditions | 4 | 4 | 4 | 4 | 4 |
| Affecting Display's active area | 4 | 4 | 4 | 4 | 4 |
| Small air gap | 4 | 4 | 4 | 4 | 4 |
| Suitably mounted front plate | 4 | 2 | 3 | 4 | 4 |
| Suitable actuator's position | 4 | 4 | 4 | 4 | 4 |
| Holder's required integration space | 3 | 2 | 3 | 4 | 4 |
| Sum | | 78 | 85 | 92 | 92 |
| Percent % (rounded) | | 85 | 92 | 100 | 100 |

In the first variant, an additional housing is necessary because the front plate's mounting options are questionable. In variants *B* and *C*, the holder can replace the housing, wherein variant *C* requires least space, because it does not need to surround the glass and can, thus, be designed narrower. The glass plate in variant *B* is also suitably mounted inside the housing where a foam element enables the movement, but the use of a transparent adhesive has more advantages in the final integration process. This is why variant *C* got more points eventually.

It can be seen how progressively the selection tables have higher overall sums, as the proposed concepts are improving. The actuator might have a suitable position being mounted beneath the glass plate, and, therefore, get the maximum points in the table. However, it will be seen in the final concept selection that there are differences regarding these criteria, especially when liquid adhesive is used.

- Concept IV – Piezo separated from the adhesive

Table 20. Concept IV - selection

| Assessment criteria | Priority | A | B | Ideal |
|-------------------------------------|----------|----|------------|-------|
| Sealing conditions | 4 | 4 | 4 | 4 |
| Affecting Display's active area | 4 | 3 | 4 | 4 |
| Small air gap | 4 | 4 | 4 | 4 |
| Suitably mounted front plate | 4 | 4 | 4 | 4 |
| Suitable actuator's position | 4 | 4 | 4 | 4 |
| Holder's required integration space | 3 | 3 | 4 | 4 |
| Sum | | 85 | 92 | 92 |
| Percent % (rounded) | | 92 | 100 | 100 |

Variant *B* has got just a few more points. Despite the fact that the glass is properly connected to the rest of the system by using the liquid adhesive in both options, the second variant has an additional support element for the glass thanks to the holder design. Further, in the first variant the actuator module is not closed from both sides. For protection reasons an additional housing might be planned. This could increase the integration space of the prototype.

5.4.2. Final concept selection

The following table consists of four solutions which are evaluated in the final concept selection. Each concept and its variants differed in the mounting options and sealing conditions. Excluding other concept ideas in the initial selection stage makes it easier to compare the best solutions in one table with respect to their properties and overall quality. In this table, the given points refer to the requirement in comparison to concepts which made it to the final selection. This means that the points differ from the points given in the previous tables where each concept was evaluated separately.

Table 23. Final concept selection





| Concept | | I-D | II-B | Ideal |
|-------------------------------------|----------|---|--|-------|
| Assessment criteria | Priority |  |  | |
| Sealing conditions | 4 | 4 | 4 | 4 |
| Affecting Display's active area | 4 | 2 | 3 | 4 |
| Small air gap | 4 | 0 | 4 | 4 |
| Suitably mounted front plate | 4 | 3 | 3 | 4 |
| Suitable actuator's position | 4 | 3 | 2 | 4 |
| Holder's required integration space | 3 | 4 | 2 | 4 |
| Sum | | 60 | 74 | 92 |
| Percent % (rounded) | | 65 | 80 | 100 |

Table 24. Final concept selection – continued

| Concept | | III-C | IV-B | Ideal |
|-------------------------------------|----------|---|--|-------|
| Assessment criteria | Priority |  |  | |
| Sealing conditions | 4 | 4 | 4 | 4 |
| Affecting Display's active area | 4 | 4 | 4 | 4 |
| Small air gap | 4 | 4 | 4 | 4 |
| Suitably mounted front plate | 4 | 4 | 4 | 4 |
| Suitable actuator's position | 4 | 2 | 4 | 4 |
| Holder's required integration space | 3 | 4 | 3 | 4 |
| Sum | | 84 | 89 | 92 |
| Percent % (rounded) | | 91 | 97 | 100 |

The first solution did not get too many points because of the huge air gap. Actually it could have been excluded from the table at the beginning, but it was included as the best variant in the first concept ide for representation purposes.

Similarly, the second concept was shown and compared in the final table because it was the best variant in the concept where the actuator is mounted laterally. However, compared to concepts III and IV, the holder might affect the display's active area and integrating the glass plate inside the holder can be more complicated than just bonding it onto the display unit.

When considering details of concepts III and IV in detail, they look very similar. Regardless, in this instance of the concept development phase, the fourth concept is the most favorable according to the evaluation criteria and above priority table. The actuator is protected from both sides and, unlike the third concept; the liquid bonding material cannot affect the actuator. For this reason, the third concept got just 2 points with respect to actuator position criterion, despite being attached under the glass plate as well.

Subsequently, when an actual display is being assembled, it will be seen whether the glass plate is wide enough to cover the holder with the piezo element inside. It might result in

another modification of the fourth concept where the support surface is removed. In this case, the holder would not be wider than the actuator and glass plate. Since it would not be closed from both sides, some kind of housing would have to be used if it turns out to be necessary for the prototype design.

These are additional assumptions and will be discussed and elaborated if the prototype design requires it.

5.4.3. Kyocera support equipment

Kyocera Display in Dietzenbach, Germany, provided the piezoelectric actuators, circuit board, connection cables, and software for the purpose of this project. Pictures of the necessary hardware can be seen at the end of this document (in [Appendix III](#)). After the concept selection was closely discussed, the Kyocera team suggested some modifications and gave appropriate advice for the prototype design.

The glass plate has to be pushed down by a human finger, so a soft element should be inserted between the holder and the cover glass, e.g. by using a simple double-sided adhesive tape. The prototype would probably not work as it is presented in Figure 49. Additional support surfaces for the glass plate might have a contradictory effect, because they would require more space covered with the tape. Too much tape would dampen/soften the vibration. Detailed consultation led to the final, fifth concept.

It is very important to stress out, that the concept development phase for this Master's thesis might have been finished sooner if the components for the prototype design were actually known from the beginning. Thus, it would have been easier to visualize the dimensions of the components and other separation possibilities of an LCD would be considered, not just the separation of the cover glass.

Due to the aforementioned partnership, Kyocera supported the prototype design by sending separated backlight units from the bonded LCD and cover glass. The components were originally installed in a BMW 8.8 inch iDrive display. Eventually, it turned out that the prototype will not have the cover glass separated from the LCD glass, but those bonded glass plates would be separated from the backlight. The selected concept did not have to be changed drastically, although some changes have been made. For instance, the LCD and cover glass were held firmly within a plastic housing, whereas the backlight's height is 6 mm and carries noticeably the most weight. Corresponding pictures are included in [Appendix III](#).

- Contrast enhancement films and optically clear adhesives

Liquid optically clear adhesives (LOCAs) have to be cured with UV light with an exact wavelength (400 nm³⁰ for the DELO PhotoBond OC4022³¹) which was the recommended acrylate adhesive with low viscosity. Therefore, this is a process which is actually fully automated and done in their laboratory in Windach, Germany. Their engineer Uwe

³⁰ nm – 10⁻⁹ m

³¹ <https://www.delo-adhesives.com/en/downloads/>

Allendorf secured two sample tubes of the adhesive, but Edag might not have the exact equipment, and bubbles can easily occur if it is not used properly.

Therefore, for the prototype design optical clear adhesive films (OCAs) have also been chosen. Tesa³² (175 μm) and 3M (150 μm) sent their samples for outstanding lamination. Those films should also be applied carefully (rolled up), and under specific circumstances such as in vacuum in order to avoid air bubbles.

Eventually, it has been found that the prototype design is a compromise between having a real demonstrator without any drawbacks considering every possible requirement, and having a somewhat simpler device with a satisfactory haptic feedback similar to a button click.

³² <http://www.tesa.com/industry/electronics/applications/optically-clear-lamination>

6. CONCEPT ELABORATION

6.1. Concept V – Prototype based on Kyocera's backlight

The final concept is a combination of all previous considered variants, especially referring to concept IV, because optically clear adhesive was still foreseen as viable solution. However, this time it has been decided to try out an optically clear film as an alternative to the liquid adhesive. Namely, in the aforementioned case adhesive leakage does not have to be considered in the holder design. It is much more important to allow the cover glass to be pushed in slightly, and that the connection method and locations do not dampen out the haptic feedback vibrations.

The final holder design is shown in Figure 50. It is designed to exactly match the dimensions of the iDrive backlight. The backlight was laterally connected to the housing by M3 screws. Since the bonded LCD and cover glass will not be used in the prototype design (because they are firmly held within the plastic housing, see the [Appendix III.](#)), the holder has holes for the same screws with the identical distance as in the backlight. However, when separation of the LCD and cover glass has been attempted by applying warm air at the edges where adhesive has been previously applied to dispose of the plastic frame, the cover glass broke. For this reason, two 1 mm thin glass plates were ordered. To compare the feedback on real glass and plastics, two 1.5 mm thin PMMA³³ plates were used in the prototype design as well.

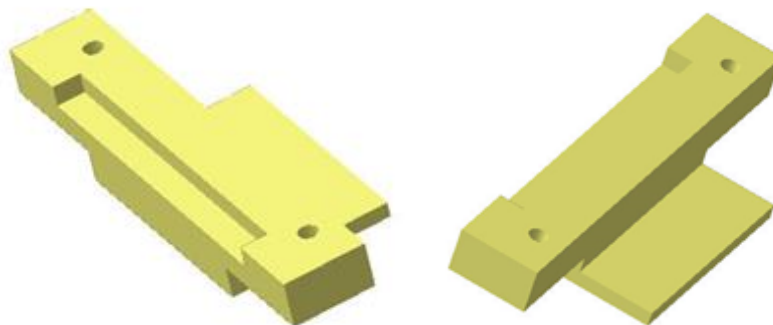

Figure 50. CAD model - final holder

The assembly sequence might be envisaged in the following way:

- Screwing the backlight and holder together
- Placing the holder on a plane table
- Gluing the piezoelectric actuators within the small slot (possibly with a drop of glue on the upper elastomer element)
- Applying double-sided adhesive ~ 0.5 to 1 mm on the upper surface
 - Important: only small pieces of tape should be used so that the cover glass vibration would not be excessively dampened
- Applying the two previously optically-bonded glass plates (each presenting the LCD and cover glass)

³³ Poly(methyl methacrylate) – known as acrylic glass, plexiglass

- Filling the gap between the backlight frame and LCD glass with pieces of adhesive tape including protective film used to prevent overturning (for subsequent sealing conditions foam material should be used)

This procedure is easier to visualize when considering the graphical representation of the LCD system given in Fig. 51. It includes the design of the whole prototype in CAD software, with the detailed explanation given below.

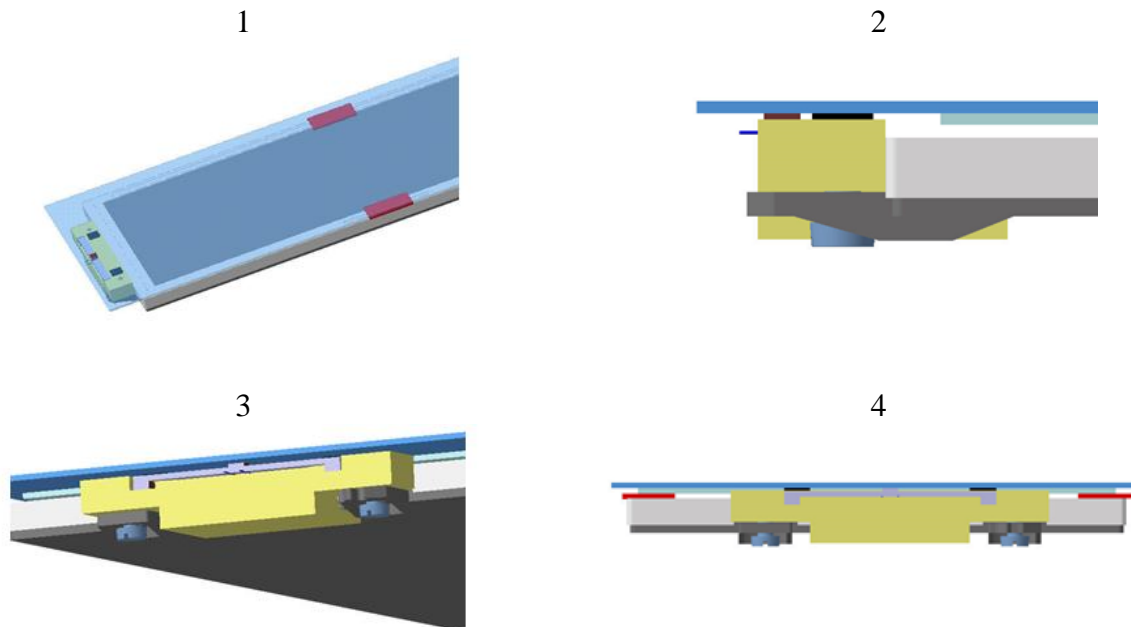

Figure 51. Entire prototype in CAD

As mentioned before, the backlight and its frame were designed using CAD according to the specifications of the original 8.8 inch display. A slot is foreseen within the holder to mount the piezo actuator with its elastomer elements in a precise manner, because in this design, the piezo actuator is in direct contact with the cover glass. Small pieces of self-adhesive tape (black) will be attached to the upper surface which will hold the bonded cover glass in place. Additional pieces of tape (red) can be inserted into the necessary air gap between the LCD glass and the frame in order to prevent overturning of the device when the finger is pushing the glass. Note that without the aforementioned gap, the upper glass cover could not be pushed in. For real implementations, instead of red tape pieces, an appropriate sealing element should be used to fill the gap.

Since additional glass plates needed to be procured, their dimensions were similar to those of the iDrive display. The local glazier's workshop regularly sells 2 mm thick glass plates, which is too thick for this application (i.e. it would result in 4mm thickness after bonding). Hence, 1mm thick glass plates were specially ordered from another more specialized shop (220 x 90 x 1mm and 260 x 100 x 1 mm). The purchased PMMA plates have similar size.

After the two pieces of the holder were produced on the milling machine from the material Polyamide 6.6 (for the corresponding 2D drawing, please see [Appendix II](#)), and optically-

adhesive material was received from DELO, Tesa and 3M, it was just necessary to wait for the glass plates to assemble the first prototype.

6.2. Demonstrator design

- Gluing the glass plates

Gluing the two 1 mm thin glass plates together was probably the most demanding phase of the whole assembling process. Namely, gluing can be performed in various ways and it makes quite a difference whether liquid adhesive or technologies like thin optically clear films/tapes are used. Some cover plates in displays are more flexible and some are more rigid. Both of the methods should happen in exactly determined circumstances in order to achieve the desired conditions. For satisfactory clarity and transparency, the occurrence of air bubbles must be avoided. On the other hand, if the focus is put on testing the haptic feedback possibility of the actuator, air bubbles would not likely present an issue during prototype testing phase. However, the 3M contact person, Michael Patz, fears that bubbles might still negatively influence the transmission of the vibration. For example, the declared dynamics of the actuators might not be adequately presented, which would, in turn, be further obscured if air bubbles would play a significant role in the vibration attenuation. Tesa's market manager, ÖzgürkanSayir, does not hold this opinion. Both of them provided detailed application notes for manual application of the recommended film since special lamination equipment like laminator machines, rollers or autoclaves (for removing entrapped air) are unfortunately at the team's disposal at this stage of R&D. The recommended and received 3M sample was OCA 8416-6. The last number stands for the thickness (6 ml , 150 μm), which is roughly 10% of the glass plate thickness. Unfortunately, thinner adhesive sample was not available at the moment. For comparison, Tesa's recommended product was Tesa®69507 (175 μm).



Figure 52. 3M OCA 8416-x

These OCAs are usually delivered in roll formats (tapes) and provided for roll-to-roll touch sensor lamination. 3M and Tesa supported the prototype development with a few adhesive films in DIN A4 formats.

The main characteristics are:

- High adhesion
- Easy to convert and cut

- ITO³⁴ compatible
- Excellent option for bonding both PMMA and glass plates

The optimal required conditions for the laminating process include a clean room area (temperature of 24°C and above), clean rubber roller (highly recommended; because it can be used to squeeze out the air), and isopropyl alcohol for cleaning the surfaces. Another reason why glass as cover material is preferred is that it does not have to be pre-baked. If plastic substrates such as PMMA were used, moisture should be driven out and the plates would be first placed in an oven for 2-5 hours. The thicker the plastic, the longer it takes to remove moisture from it.

It is recommended to apply the OCA first on the cover glass, while the LCD glass should be attached to the OCA in the subsequent step. In an ideal case, the second glass substrate has some flexible properties similar to the OCA material.

The explained process and Tesa's OCA is used for bonding the 1.5 mm thin PMMA plates. Due to the lack of additional equipment, the presence of air bubbles could not be avoided. For optical transparency/clarity reasons, two more PMMA plates were adhered with the DELO OC4022 liquid material. In the other prototype with actual glass, the same liquid material was used. In particular, by building different prototypes, the liquid technology was tested as well as the films. On the other hand, the behavior of the feedback on plastic substrates could be observed, as well, regardless of the fact whether these plastics were tempered or not. It must be stressed that PMMA plates were thicker than the real (mineral) glass plates, because thickness factors can surely influence the feedback. Since glass plates will be attached to the holder and actuator after the bonding and curing process is done (for the liquid adhesive test), leaking out of the material is prevented.

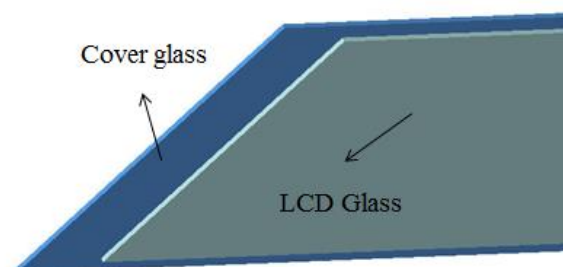

Figure 53. CAD model of bonded glass plates

- Attaching holder to backlight

The rest of the prototype development is explained in previous chapters. The holder was produced on the milling machine from Polyamide 6.6. It is a material with very good mechanical properties [49], i.e. it is hard and thermally stable. Compared to the other, often used type PA 6, PA 6.6 is characterized by higher moisture absorption rate, and it is more

³⁴ Indium tin oxide (material used for making transparent conductive coatings for displays)

expensive because it has higher impact strength and better damping characteristics. Four M3x8 screws hold the polyamide holder with the backlight from both sides.

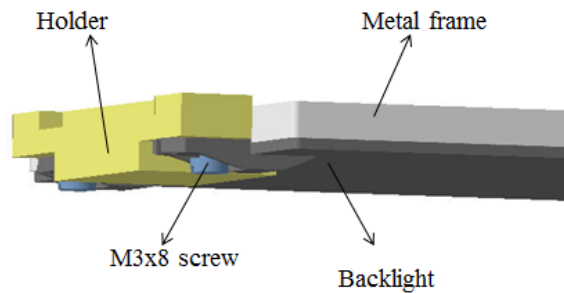

Figure 54. CAD model holder with backlight

- Inserting the piezoelectric actuators

One actuator was attached to the holder from each side. The small elastomer blocks have a thin sheet of adhesive material at the top. After removing the protective film, the piezoelectric actuator is easily inserted in the reserved slip within the holder.

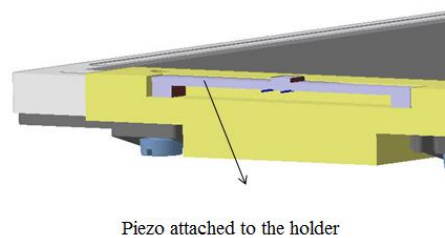

Figure 55. CAD model of the actuator's position

- Attaching pieces of adhesive tape

It is important to use only small pieces of tape in order to prevent notable attenuation of haptic feedback vibrations. Since the displacement of the glass is only around $40\ \mu\text{m}$, all such negative influences should be avoided or minimized as much as possible. The utilized 3M pressure sensitive double sided tape has a thickness of about 1 mm with the protective film, and 0.5 mm without it. For the first prototype design and testing the vibrations of the actuator, the bonded glass plates will be held in place just with those pieces of tape. Even thinner tape was briefly considered in order to reduce the possible wiggling, but the idea was quickly dismissed because certain magnitude of oscillations through the tape is required. This would not be possible with much thinner tapes.

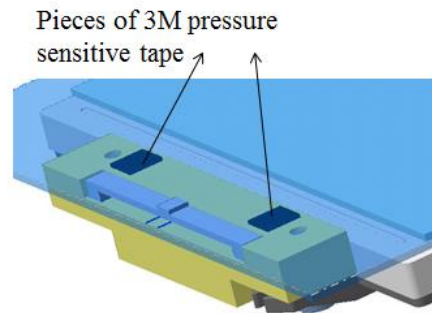

Figure 56. CAD model of adhesive tape pieces on the holder

- Preventing tipping over

For the simple prototype development purposes, the tipping over of glass plates can be prevented by using the same tape with protective film, because the glass has to be able to lean onto something. For this reason, an air gap of similar height was left between the backlight frame and LCD glass. As an alternative, a soft sealing element has been prepared, in order to cover the entire backlight stage. In this way, the system's behavior can be tested in these two distinct cases.

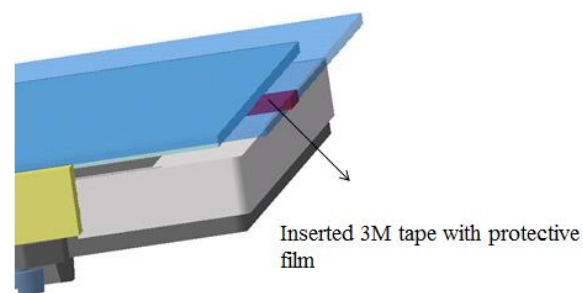

Figure 57. CAD model of the supporting material

- Circuit board and software

The last step is the installation and connection. Piezo actuators were connected to the circuit board, which can simultaneously control up to two actuators. It is important to make sure that the power supply connection cables are inserted properly to positive and negative voltage potentials. Just after the actuators are connected powerless, the circuit board is configured within the laptop's operating system, and eventually 9V voltage is applied. In Kyocera's prototype, the pressure detection is happening through the actuators. This can be done also with a touch sensor.

The Haptivity software can be seen in [Fig. 58](#). Thirty-one different patterns were developed previously, of which pattern number 16 simulates the usual button click effect with the most authentic result.

The patterns differ in intensity. Low, middle and high frequencies represent 140 Hz, 200 Hz and 300 Hz, and two-step or seven-step buttons can be simulated as well. An interesting feature is that in the auto-change mode different frequencies can be felt in the moment of

pressing and releasing the touch-screen. For example, low frequency can be used in the moment of pressing the surface, and high frequency in the moment of releasing. It makes a significant difference if both frequencies are low or both are high at the same time. If both are high, the feedback feels much sharper.

The actuator control system can also be configured so that actuators produce just a vibrational sensation in a specified vibration pattern and period (given in milliseconds). Just by changing and considering some of these options, it is possible to evaluate and estimate how the prototype design factors influence the feedback.

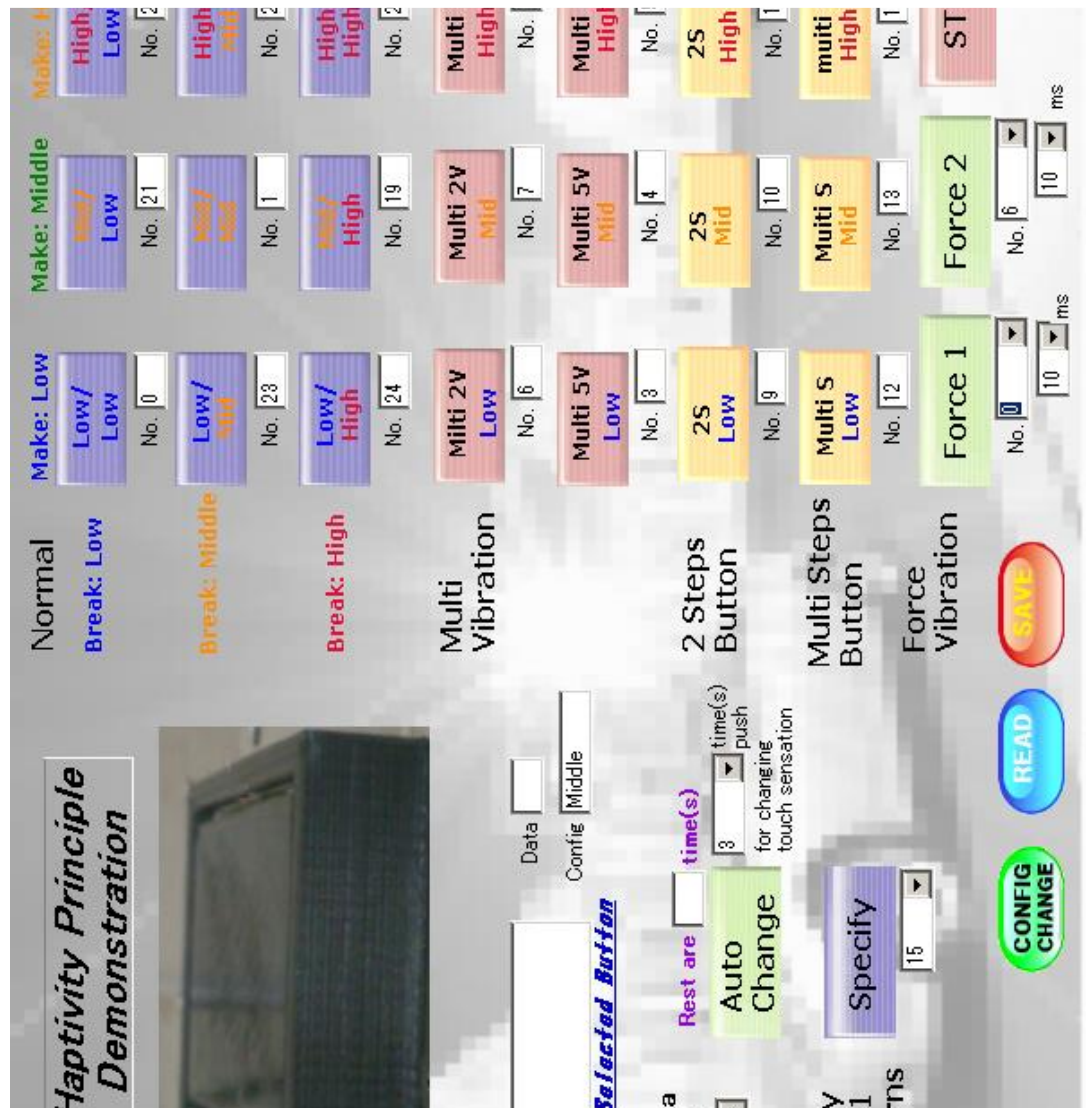

Figure 58.Haptivity software

6.2.1. Test of applicability

The very first trial of the designed prototype was with the optically bonded PMMA plates. Everything was assembled as described in the previous subchapter (see [Appendix IV](#)). At this moment it was possible to evaluate whether the theory can be assigned to practice that easily. The first answer is unfortunately no.

- Use of double-sided tape pieces (3M Scotch PST³⁵)

Even small pieces of adhesive tape between the holder and the cover plate dampened out the vibrations. After removing them, the feedback was much better. In such a design, the plate was held in place just by small self-adhesive elastomer elements on top of the actuator. Of course, the solution should be redesigned, but at least, a satisfactory haptic feedback could be felt in areas closer to the actuator. In the center of the cover plate, the feedback was non-existent. This might be due to several different reasons. One reason might be the properties of the Plexiglas and the more notable bending of the plate in the center. The other reason, which probably had more influence, was a small lump on the backlight's frame (see [Appendix IV](#)), which leads to direct contact with the cover plate. The first step in remedying this situation would be removing of the aforesaid lump. Then a solution must be found on how to fix the cover plate and how to seal up the air gap. Since the material of the sealing element must not be too thick, the idea was to use felt.

It is a textile made of either natural or synthetic fibers. Some types of felt are especially designed for technical applications. The material can differ in color, size, thickness, density and other factors specific to the usage. See [Appendix V](#) for the prototype with applied felt.

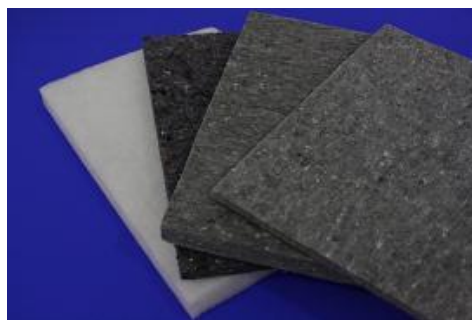

Figure 59. Felt

All the following feedback sensations are result of an objective assessment. The pattern number 16 was tested each time for comparison purposes. When felt only is used, the feedback is satisfactory on most of the backlight's area, except the corners of the glass and alongside edges (where felt would attenuate the vibrations).

In order to try out the foam rubber sealing element ([Appendix III](#)), two thin washer fasteners should be used between the holder and the screws in order to put the holder and piezo actuator in an elevated position. The rubber element is a bit thicker than the felt, so if piezo actuator would not be in the elevated position it would not be able to reach the glass plate. For this

³⁵PST- Pressure Sensitive Tape

reason the holder's side slip was cut away. Again, the haptic feedback was not optimal. The alongside edges could be marked red (unsatisfactory) as well as two corners of the glass plate. Most of the backlight's area could be marked green (satisfactory) apart from the area extremely close to the center.

However, both materials cannot solve the fitting problem. Therefore, tape was attached to different parts of the backlight's frame. Since felt was thinner, it was still present as a sealing element.

- Tape next to the piezo

This option was tried first and it has already been said that it dampened out the vibrations totally.

- Tape in the center of the frame

This assembly can be seen in [Appendix V](#). Figure 60 presents the sensation of the button click effect divided into areas. For some reason, in two corners the feedback is absent (red); while in the opposite two corners the feedback is satisfactory along with the area above the piezo actuator (green). Unfortunately, the feedback is also not satisfactory on most of the center area of the glass plate as well as above the edges of the frame. With increased distance from the area where the actuator is attached, the feedback weakens (yellow).

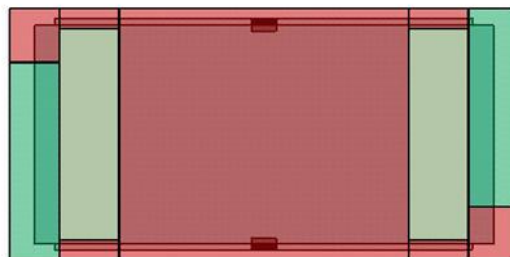

Figure 60. Objective assessment - tapes in the center

If the tape is attached in two corners, for instance, in the upper right and lower left corner, the feedback is similar to the previous combination.

- Tape in the four corners + two supporters in the center

It can be seen in Figure 61 how the feedback is transferred to the human finger when the tape is attached to the four corners of the backlight's frame with two additional tape elements in the center with protective film. This assembly should approximately simulate the case with

six tape pieces, but the glass plate might not be removed that easily without breaking it. This is why the protective film is left on center pieces. In this way, a much better haptic feedback is achieved than in the case when just two tape pieces were used in the center. However, the edge of the frame is still problematic as well as the corners because they are closer to the tape.

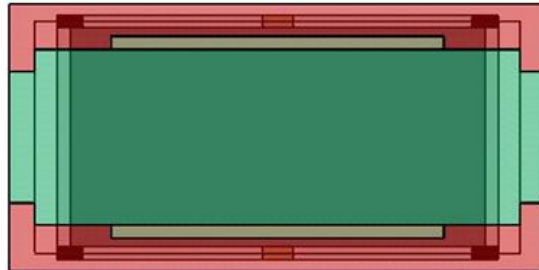

Figure 61. Objective assessment - tapes in the four corners + supporters

- Tape in the four corners without supporters

It is interesting that this time the edge of the frame is not that critical. The problematic area is the rest of the cover plate's area.

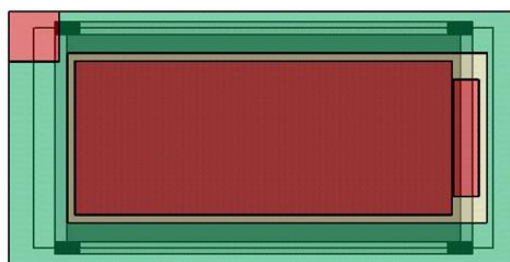

Figure 62. Objective assessment - tapes in the four corners without supporters

Apparently, something is not correct either with the attached glass plates or with the backlight. Indeed, above one actuator, the feedback was good enough, while above the other one, it was dissatisfying. Further, just in one corner the feedback was poor. Further combinations were tried out.

Attaching four pieces of adhesive tape not exactly in the corners, but a bit closer to the center, resulted also with an unsatisfactory solution. Most parts of the glass corners, the area above the edge, and the center of the backlight could be marked red.

For comparison reasons, the actuators can be placed onto the upper part of the holder, instead of mounting them onto lower tight openings where they are actually always glued. This ensures the glass plate being definitely more in contact with the actuator. Indeed, it can slightly improve the feedback, but, in turn, increases the air gap width. It appears that two additional actuators should be attached at the center of the long edges of the device in order to achieve optimal actuator performance. Since the Haptivity software supports the control of two actuators simultaneously (as already mentioned), another chip should be installed on the circuit board for this purpose, which would not be possible according to the requirements of this R&D project.

6.3. Optimization possibilities

Considering the outcomes in the previous subchapter, regarding the adhesive tape use, a totally different solution should be found, and the adhesive tape must be excluded from the design. Some possibilities include the use of steel spring elements, liquid adhesive which simultaneously plays the role of a sealing element (2-component epoxy resin adhesives), or changing the entire holder design. Unfortunately, each idea which is not tested in practice remains just a theoretical assumption.

Eventually, the study might result with the conclusion that two actuators are not enough to overcome the damping problem. Just in case, Kyocera was contacted in order to provide an additional circuit board with actuator drivers. Then, four actuators could be tested at the same time. Unfortunately, the software can simultaneously control two actuators, and this approach cannot be tested.

Possibly, the easiest way to resolve the damping problem would be to find a suitable soft sealing element, whether a single or double-sided foam tape. A double-sided foam tape could simultaneously solve the sealing and fixing problem by using a single commercially-available product.

- Damping properties

Obviously, damping properties of different materials must be studied. Tatjana Haramina, an associate professor at the department for materials (University Zagreb) was contacted. In general, materials with fewer defects will have a less damping effect. Single-crystal silicon or synthetic sapphires are representatives of such materials. Metal seals exist as well (aluminum or copper), but it is questionable whether they might be used due to the fragile structure of glass. Plastics or rubber will definitely dampen vibrations to some extent. If the connection can be permanently bonded, polyester resin or a PMMA solution in acetone can be tried out. The temperature of so-called glass-to-rubber transition, T_G , should be as far away as possible from the temperature at which the device is being used. The damping effect is most expressive in the temperature interval close to T_G . Above this temperature a firm polymer changes its condition into a rubbery or viscous, reminiscent of elastomers and their properties.

Generally, metals used for vibration dampening include shape-memory and other similar alloys [56]. The fastening method should not necessarily be irreversible for the prototype design, and installing of final metal seals might be postponed in the first run. Favorable and straightforward solutions are desirable in this stage of product development and testing.

6.3.1. Foam Tape

Again, Tesa's market manager, O. Sayir, provided samples of three different foam tapes. He claims that the recommended products are often used in similar applications. Due to the doubt whether using products with double-sided adhesive could result in excessive (too stiff) fixing of the glass plate, a single-sided foam tape was also considered. The considered tapes, tesa®62932³⁶ (0.5 mm), tesa®68669³⁷ (1.02 mm), and tesa®ACX^{plus} 7808³⁸ (0.8 mm) have been chosen for comparative study regarding the quality of vibration feedback. The respective samples can be seen in [Appendix VI](#).



Figure 63. Tesa62932 double-sided foam tape

The Polyethylene foam tape presented in Fig. 65 did not give a satisfactory feedback. It is 0.5 mm thick (i.e. rather thin), and despite being soft, two actuators could not transmit the feedback equally to the glass plate. Moreover, there was almost no feedback in the center. To separate the glass from the tape without braking the cover for further trials, heat was applied.

In the meantime, the 0.8 mm thick (60% thicker compared to previous case) double-sided-adhesive acrylic foam tape was tried in combination with the bonded PMMA plates. Just areas close to the actuator gave a satisfactory and equally intensive feedback.

The only one-sided-adhesive tape was ultra-soft polyurethane foam. It was tested with PMMA plates. In this design, despite the fact that the glass is not even being held in place, the feedback in the center was totally absent. A quarter of the glass plate's area to the left and right side provides the feedback, but above the long edges of the backlight's frame the feedback cannot be felt.

6.3.2. Simple PVC film

Whereas felt itself was not the most optimal solution, a temporary design might consist of a thin hard PVC film formed to a shape reminiscent of “lips” on each side of the backlight's frame (see [Appendix VII](#)). Each corner would not be closed entirely, but the feedback should be tested ascertain the material's effect on the previous damping problems. The in-house

³⁶ <http://www.tesa.com/industry/tesa-62932.html>

³⁷ <http://www.tesa.com/industry/tesa-68669.html>

³⁸ <http://www.tesa.com/industry/tesa-acxplus-7808-black-line.html>

warehouse was searched to find an adequate material which might meet the expectations. At first appearance, the product Oracal®751C High performance Cast³⁹ could be tried out.



Figure 64. Oracal PVC film

This material is very thin indeed (just 0.06 mm thick) without protective paper and adhesive, and is extremely durable and dimensionally stable. Even the temperature resistance is in the range of -50°C to +120°C.

As expected, it increased air gap to some extent, so additional screw washers were inserted. The tape held the glass in place, after which the pattern number 16 was tested.

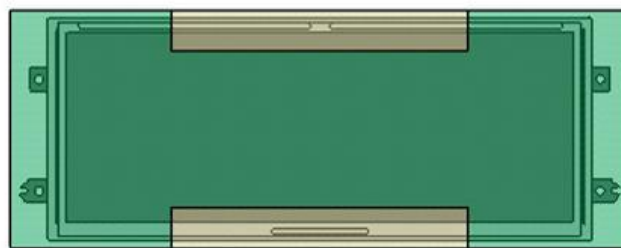

Figure 65. Objective assessment - use of PVC film forming lips

The feedback was incomparably better than in the previous design. The button-click effect can be felt in each corner of the cover glass. Areas where slightly more force has to be applied are marked yellow, but the feedback is still present. Even though this solution should be further improved, the prototype design and the desired feedback certainly shows progress.

6.3.3. Rubber hose

Since the foam tape did not work well, another idea ought to be tried out. After some re-considering, the elastomer elements attached to the actuator are also found to have a dampening effect. They can easily be removed, and for instance, be replaced with small and thin aluminum elements glued to the piezo's metal plate. But first, to avoid damage of the actuators by attaching aluminum, another possibility to seal the air gap might be inserting a thin rubber hose. The compression should be different because the hose is hollow. The material should still be soft enough. Rubber cable sleeves were used in this application.

³⁹ <http://www.orafol.com/gp/europe/en/products/search-result-gp-product-details/items/oracal-751c-high-performance-cast>



Figure 66. Thin rubber hose

If adhesive tape is used just on the backlight, this rubber hose plays a similar role to the one-sided adhesive Tesa tape. The design was tried out with the real glass plates. Very thin double-sided-adhesive tape was applied to the backlight's frame to place the rubber hose onto it, whereupon the glass was leaned onto the hose. This approach is similar to the trial with one-sided-adhesive Tesa PUR⁴⁰ foam tape.

Fig. 67 represents the objective assessment of the feedback. It is quite efficient, but it is necessary to push the center of the glass plate with more force (orange). Nevertheless, the feedback is at least present when compared to some of the previously considered cases. The prototype of this approach can be seen in [Appendix VIII](#).

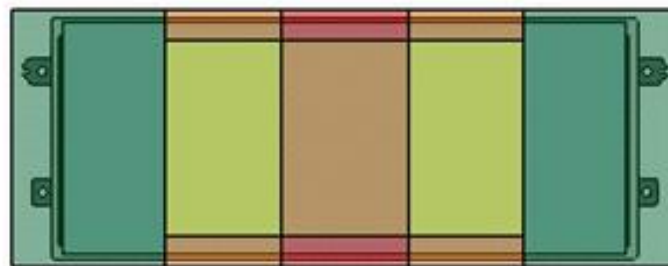

Figure 67. Feedback with rubber hose –single sided glued

A different scenario occurs if the thin adhesive tape is attached on the upper side of the rubber hose in order to fix the glass. An eight of the glass plate from both sides has a noticeable feedback. The center can be marked red due to almosinperceptible feedback, while the area

⁴⁰ PUR - Polyurethane

between is marked rather orange because much force has to be applied to provide a perceptible feedback. This amount of force is much higher than a user would usually apply on a touch screen. The edges above the backlight's area are more problematic than in the previous case.

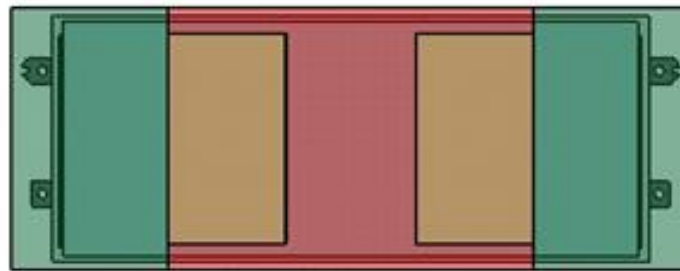

Figure 68. Feedback with rubber hose - double sided glued

6.3.4. Labyrinth seal

Eventually, a last possibility to fix and seal the glass with one product was tried out. It would be useful to find out why all former seal elements, which are actually often used for similar applications, dampened out too much the perceptible feedback. The first idea was always that the material of the sealing element has the greatest impact. Facts whether the material is too soft or hard were also reconsidered. The air itself in the gap can be the reason for the dampening effect, if notable compression and expansion is achieved within the limited internal volume of the device. Hence, the damping might be different if underpressure or overpressure is present inside the touch device. Theoretically, a certain experiment could be tried out. If a small pipe would pass through a soft sealing element, a manometer might be mounted on it. A pressure pump attached to the manometer can adjust the existing pressure. After opening the air-valve, the desired pressure can be set and the feedback re-tested., and the process can be repeated as needed. Since this approach requires much more time and equipment, a solution which allows the circulation of the air was considered instead.

If some kind of labyrinth seal could be designed, the air circulation would be enabled and the air would not be trapped between backlight and glass enclosed within the seal element under a fixed pressure. It is not 100% waterproof, but the display is anyway not foreseen to be

immersed in deep water. Automotive displays belong to the IP 65 class⁴¹. First digit indicates that the device is dust protected, while the second digit refers to resistance against medium strong water jets. The slot must not be too wide to prevent the entrance of coarse dirt particles. The sealing is better if the labyrinth element has more teeth, but then the air circulation is limited, which typically results in a compromise (a trade-off).

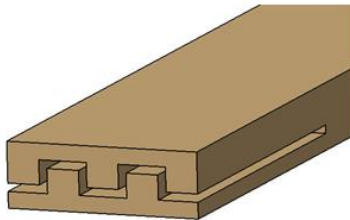

Figure 69. Possible labyrinth sealing element

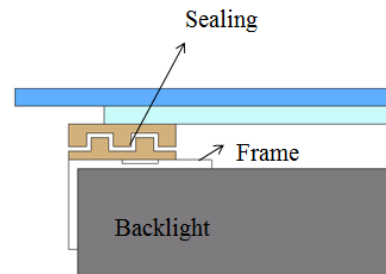

Figure 70. Section view

For representation purpose, the sealing element is designed with a thickness of 2 mm. In reality, because of the [Parallax](#) problem explained in subchapter 5.1., the air gap should not be that huge. Another question is the production technique of the sealing element. The easiest way might be the 3D printing technology. One possibility is to print the entire sealing element. The importance of the appropriate material of the sealing was discussed a lot of times. A negative influence of the printed sealing material is undesirable. For this reason, an available soft sealing element provided for such applications might be used, for instance, the tesa®68669 (1.02 mm). The foam tape might be cut in the center where a printed labyrinth sealing can be placed in and glued to the foam from both sides (see Fig. 71). Therefore, the labyrinth sealing should be 1.02 mm thick with an approximately 0.25 mm thin slot in the so-called Zik-Zak design. Unfortunately, even with the 3D printing technology, such small parts with thin slots are not that easily manufactured and might be prohibitively expensive.

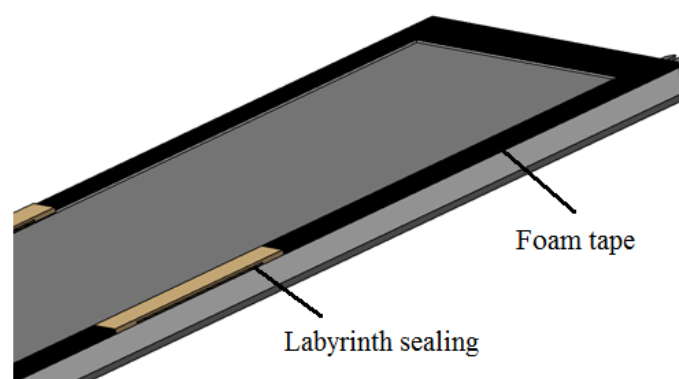

Figure 71. Prototype example with a labyrinth sealing

Fortunately, the 3D printing technology is available in the company as well. It is worth a try to find out whether a 1 mm sealing element can be produced and if the thinnest part (0.25 mm) will break under strain. The sealing was designed from two separate parts in order to

⁴¹IP – International Protection Class (Protection against contact and infiltration of dirt and water)

make the printing procedure easier. Those parts would later be glued together. For the enclosed drawing see technical documentation in [Appendix II](#).

The printer was Objet30 Pro⁴² from Stratasys and the material used was PolyJet Photopolymer. Models with PolyJet materials are precisely printed in layers as fine as 16 microns for smooth surfaces and complex geometries [50].

Somewhat surprisingly, the parts were printed successfully. However, the air circulation is likely to be very limited and might be problematic due to the very thin slot. The printed sealing can be seen in [Appendix IX](#). The one-sided adhesive foam tape was stuck on the backlight's frame. The 2 mm thin sealing was placed in the center from one side and glued to the frame with superglue. In order to fix the PMMA plate, the 0.5 mm thick double-sided foam tape was put on top of the first foam tape. The piezo was not placed in the foreseen slot, but on the upper part of the holder close to the frame.



Figure 72. Feedback with foam tape and labyrinth sealing

Unfortunately, the actuator does not recognize the press in the center of the plate. However, later on, the software can be programmed in a way that a touch sensor recognizes the human finger and the piezo then gives the button-click feedback. Consequently, it could not play the role of a sensor anymore, but can be still used as an actuator. In this case, it must be at least felt equally on the entire glass surface. Particularly, if the actuator on the right side is pressed by the right hand, the left hand, which touches the center of the cover glass, should feel the feedback as well. When this labyrinth sealing is used in combination with the bonded PMMA plates and foam tape, the feedback is hardly felt in the center.

⁴² <http://www.stratasys.com/3d-printers/design-series/objet30-pro>

6.3.5. Spring steel

Metal was considered after all, because many different solutions with soft material did not give an optimal solution. Kyocera's advice was the use of leaf springs. It might be difficult to find such springs in the necessary size and shape, so sheets of spring steel were deformed in the desired way. Their height was 2 mm, width 3 mm and the length, such as the piezo actuator, 40 mm.



Figure 73. Spring steel

The idea was to place four Z-shaped spring steel elements in the corners of the backlight's frame. The pictures of the prototype can be seen in [Appendix X](#).



Figure 74. CAD model of the Z-shaped spring

The first try was with 0.4 mm thick springs. The flat part on the bottom side was glued with a two-component adhesive to the backlight's frame, while the upper flat part of the spring was glued to the glass. These points should fix the glass, but still allow for the vibrations to be transmitted uniformly. If this is possible, then just the sealing problem should be solved. This solution approach would represent the result that holding and sealing cannot be accomplished in one step or with one product, but separately.

The pattern number 16, which was previously tested in other prototype designs, did not give the best feedback on the entire glass surface, probably due to different resonance frequency of the resulting mechanical system. But trying out different patterns (different frequencies), lead to the conclusion that the feedback can be felt everywhere, still not equally. The center of the glass has to be pushed with a very high amount of force, but the button-click effect can be felt. This means that the force is successfully being transmitted from the center to the actuators which then respond with haptic feedback after recognizing the pressure.

Since fixing the springs was a solution which held the glass without preventing the feedback, next optimization steps have to be envisaged. Apparently, the spring constant plays an

important role, so it has to be determined empirically. Firstly, thinner steel was definitely considered after which a 0.25 mm sheet was used. The Z-shaped springs were this time flipped, so that the upper flat parts are supporting the vibration direction. Another thing which might improve the design was inserting additional springs in the center of the frame whose shape reminds of a bowl or the letter *U*. The lower flat part might be glued onto the frame without gluing the upper parts since its height is 2.5 mm and a certain preload is thus already achieved. This design should theoretically support the feedback in the center as well. It should be mentioned that each separation of such irreversible glued connections is under the careful use of a hot air tool in order to use the glass plates again.

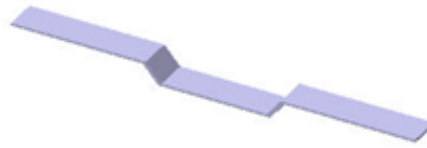

Figure 75. CAD model of the U-shaped spring

The result is better than in the first case, but still not optimal. Again, not every pattern of possible thirty-one gives the identical feedback, but at least most of them are applicable for demonstration purposes. Areas around the actuator are always the most satisfying, and moving the finger towards the center requires more force. Unfortunately, for some reason, the actuator recognizes the instant of pressing the glass in the center, but not always the instant of cover release.

The last try was with 0.1 mm thick spring steel elements. This was, so far, definitely the most promising realization. The actuators did not recognize the instance of pressing the center of the glass plate just for four patterns out of thirty-one. The vast majority of patterns represent a quite satisfactory feedback similar to a button-click about the entire glass plate surface, not just close to the actuator. Even the edges of the frame do not seem to be problematic, as was the case in previous attempts. The following table gives a feedback representation divided into patterns. Some of them already give the feedback by touching, not necessarily pressing.

Table 21. Feedback results with 0.1 mm thin spring steel

| Feedback | Pattern number |
|--|----------------|
| Suitable when pressing the center | 0-14, 19-30 |
| Requires more force in the center | 15 |
| Touching the center of the cover glass | 27-30 |
| Does not give feedback in the center | 16-18 |

Because the considered spring elements are extremely thin, it was not that easy to form the U-shaped springs which should actually support the transmitted vibrations in the center. The glass is not exactly leaned onto the upper parts of those springs, so their support is rather limited, although it works.

6.3.6. Actuators attached on the backlight's long sides

At least, a satisfactory approach was found owing to the use of spring steel. Nevertheless, there was some time left at the end of this R&D project in order to compare certain outcomes. A simple holder in an *L*-profile was designed in CAD which might be 3D-printed or produced on the milling machine quickly in order to try out whether the actuators can better recognize the pressure if they are mounted on the long sides of the backlight's frame. The holder is not intended to be connected with screws, but simply glued from the lower side of the frame. This is a quick solution for the testing of the idea, since the actuator has to be capable of pushing off of something.

The corresponding drawing can be seen in [Appendix II](#), and the 3D model is presented in Figures 76 and 77.

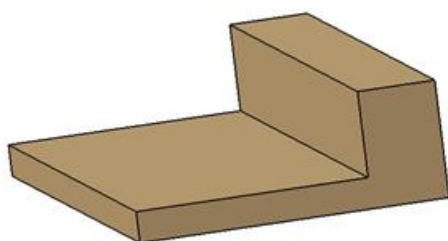
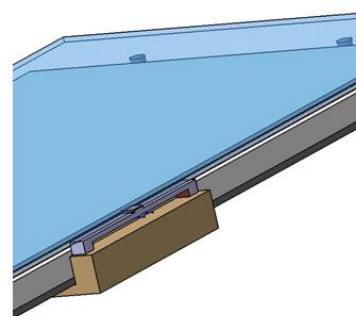
**Figure 76. L-profile holder****Figure 77. Prototype with L-profile holder**

The holder was milled and can be seen in [Appendix XI](#). The same test of applicability was utilized as in the case presented in subchapter 6.2.1, with felt and pieces of adhesive tape used therein. The tape was attached to the four corners, and the rest of the backlight's frame was

covered with felt. Figure 80 represents the result when the actuators are mounted beneath the bonded PMMA plates on the long sides of the frame.

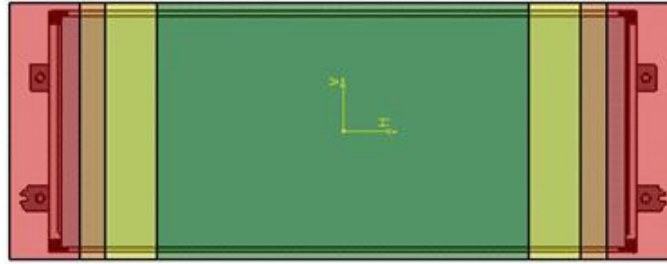

Figure 78. Objective assessment - actuators on the long sides

Compared to the case when piezo actuators are mounted laterally, the feedback is very good in the center of the glass. This is somehow also a logical conclusion. Neither the distance nor the bending of the glass can cause the actuators not to recognize the instant of applying pressure. However, this time the outer parts have shown to be problematic. This indicates that the use of spring steel with two-component adhesive is better than an approach with double-sided tape for fixing the cover plate. Nevertheless, mounting the actuators on the long sides of the frame seems to assure a better solution for a user utilizing a HMI device, because the most commands and instructions are likely to be shown in the center of the touch display.

6.4. Usability testing

In order to evaluate the final and most promising design of the haptic feedback prototype developed during work this master's thesis, a more stable demonstrator was built up with all of the previously acquired knowledge and expertise. The main purpose is to have a reliable example which can demonstrate a kind of feedback on a glass plate corresponding to the button click-effect, to the users who are not familiar with the concept of haptics.

Thus far, two small holders were milled and used for placing the actuators onto them. Their dimensions were adjusted to the screw holes of the available backlight. The solution with spring steel elements was the most satisfying for the transmission of the vibrations equally all over the cover glass, while holding it firm at the same time. Springs were placed between the backlight's frame and lower glass plate which simulates the LCD. The results presented in Subchapter [6.3.6](#) indicate that placing the actuators on the long side edges additionally assures improved feedback.

Since there was no housing so far, the final idea for conducting a survey was designing a holder which simultaneously serves as the housing. The problem of fixing the glass plate will be solved with spring steel elements and two-component adhesive, and the actuators will be placed along the long sides of the frame. Both springs and actuators are placed onto the housing, beneath the upper glass plate. A very soft TesaMoll⁴³ sealing element made of plastic foam was placed between the backlight and lower glass plate to prevent the entrance of dust. Hopefully, it should not negatively influence the feedback because of the fact that it is extremely soft and not glued from both sides. If later on, a thinner sealing element is necessary, a section was foreseen in the housing to adjust the distance of the actuator to the upper glass plate. For that purpose, a filler element was also produced on the 3D printer to close the section during the first test attempt.

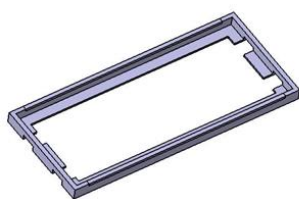

Housing

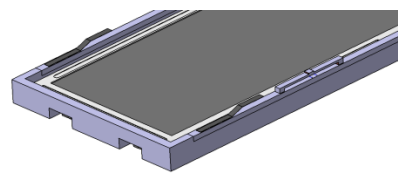

Inserted backlight with attached actuators and springs

⁴³ <http://www.tesa.com/consumer/tesamoll-standard-i-profile.html>



Sealing between backlight and lower glass plate



Final demonstrator with cover glass

Figure 79. Final demonstrator

The Tesa sealing was originally 10 mm wide. To reduce the possibility of damping, it was cut with a scalpel in the middle while a heavy block was aligned in order to cut it straight.

The final demonstrator can be seen in [Appendix XII](#). Wider glass plates were ordered. Fortunately, this time everything worked as planned and thought. The sealing did not dampen too much, the glass was glued to the 0.1 mm thin springs, and the actuators were placed on the long sides of the housing. In the first prototype, the springs were somehow smaller and placed beneath the lower glass plate (see subchapter [6.3.5](#) and [Appendix X](#)). They bent due to more weight, but unequally. This did not occur in the final demonstrator, and the space for placing the actuators remains unchanged. 1.1 mm thick fills were printed to assure that the actuator is exactly beneath the upper glass plate.

The objective assessment results again with the conclusion that the frequencies of some patterns are not suitable. All patterns can be felt, but some of them require more force. Some patterns give the double-button-click effect, while some of them provide loud and irritating feedback. This confirms that some frequencies in the software should be optimized, but at least, the demonstrator has fixed components and is sealed. These conditions were striven for the last months.

Finally, a usability study was done to determine which type of button-click effect is the most impressive. All participants had long experience of using different HMI devices. 21 users (17 male, 4 female) participated and their comments differ.

Some examples of applicable patterns which might be compared were divided into the following categories.

Table 22. Haptivity button-click feedback

| Feedback | Pattern number | Number of users who preferred the pattern |
|------------------------------|-----------------------|--|
| Usual button-click | 10 | 2 |
| | 16 | 9 |
| | 23 | 4 |
| Silent button-click | 29 | 1 |
| | 30 | 2 |
| Loud button-click | 6 | - |
| Feedback requires more force | 18 | 2 |
| Double-click effect | 3 | 1 |
| | 28 | - |

The most frequently made comments on the patterns with usual button-click feedback were that they are strong and loud, but with a good effect for a user interacting with a HMI inside a vehicle. Pattern 16 was more often preferred over pattern 23, even though both being very similar in the center of the display. Number 23 is softer, more sensitive and easier to activate. Pressing the outer areas of the glass requires applying more force in order to facilitate detection, which is likely due to different equivalent stiffness at different front panel

positions. Besides these patterns, the 10th pattern is interesting because it gives a common button feedback when pressed with less force. However, when the user presses the glass with more force, a double-click detection occurs. Two participants found this feature very favorable, while others said that it was confusing and could induce them to look at the screen (i.e. it might distract the user).

The silent button-click effect was evaluated in such a way that the feedback is made much softer, which resulted in some participants not feeling the button-click effect. Pattern number 30 is preferred over pattern 29 because it is more intense, but both of the patterns remind more on pressing something else, which just counteracts in a way not similar to a button. Moreover, one of the participants could not recognize whether he has actuated a command while driving a vehicle. It was also commented that this feedback might be more suitable for smart phones than for automotive control units. In particular, it does provide pleasant feedback, but in loud/noisy environments and inside a driving vehicle it would lead to unintentional looking at the screen. One participant found that the moment of releasing gives a noticeable feedback as well as moment of pressing. Even though he would prefer not having this effect, this feature of the particular feedback effect may be of some interest for other applications.

The pattern number 6 was also not the most pleasant for the user because the emitted sound is perceived as unpleasant (reminiscent of squeaking). For one participant it felt like a quick electric shock. The comments were interesting when the participants were asked to evaluate it without considering the loud acoustic feedback. Some participants evaluated the pattern with a satisfying button-click feedback, while other said the contrary. The effect duration is a criterion which excludes it in most cases immediately. It sounds as if a defective command (error alert) was selected. One participant said that it could be used to provide some specific commands and confirmations, not for usual driver's input command needs on a touch screen. Some of the participants claim that the sound cannot be that expressive to irritate the driver because there are enough other sounds during the ride. The feedback is unusual, impressive and "goes straight" into the finger.

The 18th pattern requires indeed more force, which might be undesirable and imprecise, but according to the comments in the conducted survey, it provides the most intensive button-click effect. One participant does not find it that difficult to actuate. Despite preferring the pattern number 23, his conclusion is that more pressing force may in some cases be an even better choice. It depends on the situation and command you want to activate. An example might be adjusting the volume; if the driver wants to significantly increase the sound intensity, much force and more intense feedback would be welcome. This is a great opportunity for further tests which might be performed in the near future considering HMIs and the Kyocera's Haptivity software. Another participant commented that this pattern is definitely advantageous for security and safety relevant confirmations inside a vehicle. This is the reason why he chose this pattern as the favorite one.

Eventually, the pattern numbers 3 and 28 are easy to release, but may frighten the user due to the double-click effect, particularly pattern number 3. Pattern number 28 is softer and less

loud. Most of the participants found those patterns irritating and annoying. Though, one participant found the 3rd pattern stronger than the 10th pattern, while another participant said it is too gentle. Pattern number 3 was the preferred pattern for one participant claiming that it is more perceptible than the other patterns.

7. CONCLUSION

7.1. Verification of the device

The requirements developed in subchapter 5.1 and shown in Table 18 are compared to the outcomes of the practical part of this thesis. The verification is the final process of the master's thesis and ascertains the quality of the developed haptic device. For this device, seven major specifications were indicated. Table 23 will show whether the condition currently present in the designed demonstrator can be applied in a later mass production device. Firstly, the requirements will be listed individually for the sake of the interested reader.

- Sealing

An air gap is necessary in each haptic device in order to allow the front plate to move. The developer decides which components will be separated: whether the cover plate is separated from the rest of the unit, or the cover plate and LCD glass are separated from the backlight. Since the cover plate and LCD glass were optically bonded in this project, entrance of any foreign particles is impossible. The space between those glass plates and the backlight has to be sealed, which is achieved by using extremely soft self-adhesive flexible foam insulation. This requirement is fulfilled for the prototype design, but, unfortunately, at this stage it is glued just from the lower side. This might not be an optimal solution for later mass production devices.

- Damping

The front plate, together with the bonded LCD glass, is subject to vibrations caused by the actuator. Every material which is in direct contact with the front plate glass can dampen the vibrations to a certain extent. The only investigated product which sealed the air gap without negatively influencing the feedback was the previously mentioned foam insulation. Trials where the glass was fixed with products which simultaneously sealed the air gap, did not assure quality feedback over the entire glass area. The highly satisfactory result was achieved in combination with spring steel elements which additionally supported the vibration transmission.

- Display's active area

Neither the milled holder, nor the printed housing, negatively influenced the display's active area. However, this requirement has to be considered in a later phase of development when the actuators and springs would be covered with a kind of plastic frame. Since the cover glass must be able to move, a very small air gap should be left between such a frame and the glass, which might be subsequently filled with a soft sealant.

- Actuator mounting

Actuators have to be fastened properly to produce the feedback, as it often happened during this work that one tenth of a millimeter of free play prevented the vibrations. These gaps between the actuator and glass plate have to be filled with easily accessible materials in order

to facilitate affordable manufacturing of the device. For individual tests, inserted adhesive tape could fix the problem of fastening, but for the demonstrator, fillers were quickly produced on the 3D printer. The actuators are then glued from the lower side, while being in direct contact to the glass through the upper elastomer block.

- Front plate's material and thickness

The material of the front plate is typically either glass or transparent plastic material. Due to better transmission of the feedback and overall sensations, real (silicate) glass plates were used. In the automotive industry, the front plate's thickness is mostly 1 mm. The structure of an LCD unit (shown in [Fig. 37.](#)) indicates that the overall thickness is 1.4 mm. For an even thinner design and the demonstrator purpose, two 1 mm thin glass plates were used to simulate the cover and LCD glass. Therefore, this requirement is completely fulfilled and is recommendable in mass production.

- Distance between front plate and display

As mentioned in subchapter 5.1., where the possible Parallax problem was clarified, the requirement is fulfilled because the cover glass and LCD are optically bonded. Though, the distance to the backlight complies with the thickness of the plastic foam sealing (5mm). A thinner sealing is beneficial. Whether the current distance negatively influences the viewing area should be tested with a working backlight.

- Front plate mounting

It has often been indicated that the front plate must not be rigidly connected so that it can be pushed in and displaced in a micrometer range by the actuator. It is optically bonded to the imaginary LCD glass and accordingly, suitably mounted. Both glass plates are fixed on spring steel elements. For a future mass production, it should be fastened onto a frame, but still with certain flexibility. However, considering the fact that fixing the glass plates was one of the most challenging issues, the current solution utilizing steel springs is more than satisfying.

Table 23. Requirements specification verification

| Requirement | Demonstrator | Mass production |
|--|---------------------|------------------------|
| Sealing | Fulfilled | Not fulfilled |
| Damping | Fulfilled | Fulfilled |
| Display's active area | Fulfilled | Possible (trial) |
| Actuator mounting | Fulfilled | Fulfilled |
| Front plate's material and thickness | Fulfilled | Fulfilled |
| Distance between front plate and display | Fulfilled | Possible (trial) |
| Front plate mounting | Fulfilled | Fulfilled |

7.2. Summary

The reason for this research and development work is designing a haptic interface aimed at enhancing interactions with HMI devices, such as touch screens in the automotive industry. Thus far, the focus has still been given to the high visual demand issue in user interfaces. Display devices have become inescapable, so understanding interface problems on these devices and improving human vs. machine interactions has a significant value. The topic has been chosen in order to contribute to the current demands in the automotive industry, and keep track of the advancing new technologies which face us in everyday life. Among various types of haptic feedback, the main focus is put herein on the button-click effect.

The thesis is composed of seven chapters. Each chapter highlights different aspects of haptic feedback possibilities. The *introductory chapter* begins with some facts about the company, which enabled building up distinct prototypes owing to the support of colleagues from different workshops. It is followed by a motivation subchapter and pointed reasons why haptics is of great interest to the automotive industry.

In addition, *chapter two* describes HMI basics, some facts about human perception and provides an overview of haptic principles. Different haptic feedback scenarios and vibration profiles are described, including alternatives to a click, confirming how powerful and exciting the technology can be.

Methods for producing haptic feedback are investigated in the *third chapter*. It is subdivided into six parts, representing the number of main actuation possibilities studied so far. Their potentials for producing a button-click effect were analyzed in detail, which made it easier to exclude some of them for the later actuator selection.

Chapter four examines the most relevant actuator requirements. Afterwards, with all necessary explanatory statements, the piezoelectric actuator was chosen. At this stage, the search for manufacturers and helpful advice led providentially to cooperation with an electronic company, which handed in the necessary hardware and software for testing the prototypes.

The *fifth chapter* points out to the main concept development problems. Namely, the practical part of this thesis is the development of a working prototype. Requirements for implementing an actuator were analyzed in the first part. Many preconditions and constraints need to be taken into account later on, such as fixing glass plates with optically clear adhesives or maintaining an appropriate distance between the backlight and screen.

Chapter six deals with the concept elaboration after all significant knowledge had been gathered from the theoretical considerations. A first prototype was developed according to the most promising theoretical concept, followed by a technical analysis. The available equipment was used, and components were milled, glued and assembled in a way to fulfill each criteria of the concept. When the applicability was tested, the development started to face the main problems including fixing the glass plates and sealing of air gaps. For this reason, the third part of this chapter concentrates on optimization possibilities which were tried out in favor of having a satisfactory and relevant demonstrator for conducting a survey in the fourth part. In

particular, 21 participants were asked to assess different button-click effects and opt for the favorite one.

Finally, the last, *seventh chapter*, contains a verification of the enclosed device and expected requirements. Actual results are given with a comparison of fulfilled and unaccomplished conditions listed in a single table. This part is followed by the summary and an outlook and definition of possible next steps.

7.3. Discussion and Outlook

This work started out as explicitly content-oriented, because a lot of research has been done on the methods for producing haptic feedback on HMI devices. Finding the balance between research, design and the final implementation turned out to be quite difficult. However, these facts made this work very demanding, but also exciting, because it was necessary to think of the same product on different levels.

Based on the research about various studies, the piezoelectric actuator seems to be the best option for providing haptic feedback for virtual buttons. The advantage of a piezo actuator is the ability to create a variety of waveforms over a wide bandwidth, which results in a wide spectrum of sensations. With other actuators, this is hardly possible.

In order to raise awareness for this interesting and challenging technology, a prototype was built and presented to broader public. It was found that feedback through piezo actuators not only improves the user performance, but it also leads to a more satisfying experience in touch screen interactions. The main requirement on the developed haptic display was to provide the user with a good haptic feeling reminiscent of a button-click. The simulations and usability study show that this part could be achieved. In particular, a solution to tackle the major weakness of touch-screen devices i.e., the lack of tactility, surely exists, though this approach still needs to be optimized. The issues which occurred during the development phase were fixing the components and assuring proper sealing conditions without dampening the vibrations and perceived feedback.

After having worked with the prototype for a while, it turned out to be a useful technology indeed. Yet, the device produces audible noise, which makes it difficult to judge how much haptics is really being used and how much information is recognized through hearing. On the other hand, in some cases (pattern numbers 29 and 30), a lack of audible feedback was reported by the participants in the usability study. Hence, it may be perceived that audible component should be included in the feedback in order to obtain a richer image of the perception. The usability study was carried out in a silent surrounding. Especially, when evaluating haptic feedback, it is difficult to simulate all the important factors that affect its usage in real-life situations. An interesting topic for further discussion is the difference between testing the device in a traffic environment. These factors could have a significant impact on the results of the evaluation.

Nevertheless, despite facing a novelty in the interaction with a display, none of the participants would turn off the haptic feedback in their in-car device if a similar, but optimized prototype, would be installed in their own car. This shows a certain trust in haptics that has to be seen as a motivation to continue working on it. Unfortunately, there isn't sufficient data from the usability study to confirm or refute that the introduction of haptic feedback will result in less reliance on visual perception. An alternative might be the use of different haptic feedback patterns for distinct buttons so that the user could recognize the buttons and controls on the screen only based on the haptic sensations they produce. Furthermore, sliders and scrollbars could assure different kind of haptic feedback to inform the location of the element. Also, it would have been beneficial if the actuators were stronger

to overcome damping (attenuation) issues which have occurred at the beginning of the development phase. For this purpose, the use of four actuators would likely be an optimal solution with respect to attenuation issues.

Observing the prototype behavior, conditions which should be further improved may become apparent. That is why experimentation with this prototype should continue, with a deeper focus on balancing the feedback equally over the entire glass plate. This could be tried out with two more spring elements glued beneath the short edge of the cover glass. A cover frame is currently absent, and the used sealing element should be thinner, if possible, glued from both sides.

Afterwards, a promising future possibility is combining different technologies within a single device. This is an area that has not been studied before and could result in profitable improvements. The type of haptic feedback method which might be of even greater interest than the button-click is the surface texture modification, even though it will take some time to have this type of smart material technology embedded in a car dashboard. This type of feedback might make touch screen interactions more natural, so the user would be able to really feel what he/she is interacting with. Namely, with physical buttons users can feel the shape and edges of the button without pressing it. This could be a significant path for future research, with the focus on how to provide richer haptic feedback for virtual buttons and how this can solve usability issues, above all, for special users such as blind or visual impaired.

Which benefits does haptic feedback give to the driver? Does haptic feedback for in-vehicle touch screens help on traffic situations? Does it release visual workload? It is difficult to answer these important questions stemming from the very beginning of the project. The main conclusion of this work is that a lot must be done in this field, beginning with studies to answer all the questions that have appeared during this project, such as vibration attenuation (damping) and sealing conditions. Little is still known how to design haptic feedback on such devices in a most promising way. Therefore, many advantageous areas for future research in the field of haptic feedback for human machine interfaces are definitely present.

REFERENCES

- [1] Edag Soulmate – When the car suddenly becomes the better smartphone. Retrieved from <http://www.edag.de/en/edag/stories/edag-soulmate.html>
- [2] Precision Microdrives – Introduction to Haptic Feedback. Retrieved from <https://www.precisionmicrodrives.com/haptic-feedback/introduction-to-haptic-feedback>
- [3] Banter B. – Touch Screens and Touch Surfaces are Enriched by Haptic Force-Feedback. Retrieved from <http://informationdisplay.org/IDArchive/2010/March/EnablingTechnologyTouchScreensandTouchSurfa.aspx>
- [4] Texas Instruments – Haptics Solutions for Automotive Applications. Retrieved from <http://www.ti.com.cn/cn/lit/ml/slyt539/slyt539.pdf>
- [5] Texas Instruments – Touch Screen with Haptic Feedback. Retrieved from <http://www.ti.com.cn/cn/lit/ug/tidu968/tidu968.pdf>
- [6] Elektroniknet.de – Erhebliche Verbesserung des Bedien-Erlebnisses. Retrieved from <http://www.elektroniknet.de/optoelektronik/displays/artikel/78770/>
- [7] Design & Elektronik Entwicklerforum. Retrieved from <http://www.hmi-entwicklerforum.de/home.html>
- [8] IT Wissen – Das große Online-Lexikon für Informationstechnologie. Retrieved from <http://www.itwissen.info/definition/lexikon/human-machine-interface-HMI-Mensch-Maschine-Schnittstelle.html>
- [9] Blattner A. (2014). Doctoral Thesis TU München: Bedienkonzeptentwicklung für Fahrerinformationssysteme basierend auf einem Touchpad mit haptischer Rückmeldung
- [10] Samur E. (2012). Performance Metric for Haptic Interfaces. Chapter: State of the Art; Evaluation Studies
- [11] Akamatsu M., MacKenzie I.S., Hasbrouc T. A Comparison of Tactile, Auditory, and Visual Feedback in a Pointing Task Using a Mouse-Type Device. Retrieved from <http://www.yorku.ca/mack/Ergonomics.html>
- [12] Chouvaradas V.G., Miliou A.N., Hatalis M.K. Informatics Department, Thessaloniki, Greece - Tactile Displays: Overview and recent advances. Retrieved from <http://citeseerx.ist.psu.edu/viewdoc/download?doi=10.1.1.449.1398&rep=rep1&type=pdf>
- [13] Saddik A. El., Orozco M., Eid M., Cha J. (2011). Haptics: General Principles;

- [14] Tyson R.K. (2012). Adaptive Optics Progress. Chapter: Dual Conjugate Adaptive Optics Prototype for Wide Field High Resolution Retinal Imaging. Retrieved from <http://www.intechopen.com/books/adaptive-optics-progress/dual-conjugate-adaptive-optics-prototype-for-wide-field-high-resolution-retinal-imaging>
- [15] Haptics and HMI. Retrieved from <http://analysis.telematicsupdate.com/telematics/haptics-and-hmi>
- [16] Lust M., Schaare R. (2016). ATZ – Automobiltechnische Zeitschrift, Chapter: Bedienoberflächen mit aktivem haptischen Feedback
- [17] Maxim Integrated - Tactile feedback solutions using piezoelectric actuators. Retrieved from <https://www.maximintegrated.com/en/app-notes/index.mvp/id/4706>
- [18] University of Tampere, Finland; Haptic Touch Screens for Mobile Devices: Feedback & Interaction. Retrieved from <http://www.sis.uta.fi/~hui/mobile/papers/Muller-paper.pdf>
- [19] Jacko Julie A. (2012). The Human Computer Interaction Handbook: Fundamentals, Evolving Technologies, and Emerging Applications. Chapter: Technology and Production of Tactile Feedback
- [20] Aito, Holland – Localized HD Haptics for Touch User Interfaces. Retrieved from https://aito-touch.com/wp-content/uploads/2014/03/AIA002WPA2_Haptics_Touch_v2.pdf
- [21] Brown L.M., Brewster S. Tactons: Structured Tactile Messages for Non-Visual Information Display. Retrieved from <http://crpit.com/confpapers/CRPITV28Brewster.pdf>
- [22] Kyocera United Kingdom, Haptivity. Retrieved from http://www.kyocera.co.uk/index/products/lcds_glass_glass_touch_panels/haptivity.html
- [23] Yem V., Okazaki R., Kajimoto H. (2016). Haptics: perception, Devices, Control and Applications. Chapter: Low-Frequency Vibration Actuator Using a DC
- [24] iMore – The science behind Force Touch and the Taptic Engine. Retrieved from <http://www.imore.com/science-behind-taptics-and-force-touch>
- [25] Saily H. Haptics in Touch Screens. Retrieved from http://www.uta.fi/sis/tie/him/schedule/Heikki_Saily_presentation.pdf
- [26] Huotari V. - Tactile Actuator Technologies. Retrieved from http://www.uta.fi/sis/tie/him/schedule/Vesa_Huotari_presentation.pdf
- [27] Texas Instruments – High-definition haptics: Feel the Difference. Retrieved from <http://www.ti.com/lit/an/slyt483/slyt483.pdf>

- [28] Precision Microdrives – Understanding ERM Vibration Motor Characteristics. Retrieved from <https://www.precisionmicrodrives.com/application-notes/ab-004-understanding-erm-vibration-motor-characteristics>
- [29] Precision Microdrives - Integration Guide; Haptic Feedback & Vibration Alerting for Handheld Products. Retrieved from https://www.precisionmicrodrives.com/sites/default/files/haptic-feedback-vibration-alerting-for-handheld-products_0.pdf
- [30] DRV2603 Haptic Drive With Auto-Resonance Detection for Linear Resonance Actuators (LRA). Retrieved from <http://www.ti.com/lit/ds/slos754c/slos754c.pdf>
- [31] Texas Instruments – Haptic advancements put us in touch with complex systems. Retrieved from <http://www.ti.com/lit/wp/sszy014/sszy014.pdf>
- [32] Haus H., Kern T., Matysek M., Sindlinger S. (2014). Engineering Haptic Devices; A Beginner's Guide. Chapter: Actuator design
- [33] Yang Yi. (2013). Doctoral Thesis: Design and Control of an Integrated Haptic Interface for Touch Screen Applications. Retrieved from <https://ori-nuxeo.univ-lille1.fr/nuxeo/site/esupversions/597793bd-73ee-4eac-aa76-1fe5c409b2f1>
- [34] Chan K.S., Hon Y.T., Kil H.B., Soo K. D. - Interaction with a Display Panel – an Evaluation of Surface-Transmitted Haptic Feedback
- [35] Hatzfeld C., Kern T.A. (2014). Engineering Haptic Devices; A Beginner's Guide. Chapter: Development of Haptic Systems
- [36] Price S., Jewitt C., Brown B. (2013). The SAGE Handbook of Digital Technology Research. Chapter: A Brief Introduction to Haptic Perception
- [37] Wijekoon D., Cecchinato M. E., Hoggan E., Linjama J. (2016). Haptics: perception, Devices, Control and Applications. Chapter: Electrostatic Modulated Friction as Tactile Feedback: Intensity Perception
- [38] TESLATOUGH – Electro vibration for touch surfaces. Retrieved from <http://www.olivierbau.com/teslatouch.php>
- [39] Richtlinie VDI 2225 Konstruktionsmethodik (1998). – Technisch-wirtschaftliches Konstruieren – Technisch-wirtschaftliche Bewertung
- [40] Yatani K. (2011). Doctoral Thesis University of Toronto: Spatial Tactile Feedback Support for Mobile-Touch-screen Devices
- [41] SHIVR HEK-200 Multi-Actuation Haptic Evaluation Kit: Operation Manual. Retrieved from N. Jared Keegan (Division Director Mide Technology Corporation, Medford, MA, USA, 31st August 2016)

-
- [42] Meier M., Swiss Federal Institute of Technology Zürich. Auswählen und Bewerten Retrieved from <http://e-collection.library.ethz.ch/eserv/eth:25112/eth-25112-01.pdf>
- [43] Stockwell Elastomerics; Touch Screen Gaskets. Retrieved from <http://www.stockwell.com/touch-screen-gaskets.php>
- [44] Newhaven Display; Touch Panel Integration Guide. Retrieved from http://www.newhavendisplay.com/tp_integrationguide.html#link3
- [45] DELO; Display and Touch Panel Bonding. Retrieved from <https://www.delo-adhesives.com/en/display-bonding/>
- [46] LOCTITE Light Cure Adhesives. Retrieved from <http://www.loctite.com.au/cover-lens-bonding-tp1-6029.htm>
- [47] Bridge – A Ximedica Company; Touch screen Ergonomics, The key to seamless usability. Retrieved from <http://bridgedesign.com/touch-screen-ergonomics/>
- [48] Jänsch J., Birkhofer H. (2006). International Design Conference Dubrovnik - The Development of the Guideline VDI 2221 - The Change of Direction. Retrieved from <http://docentes.uto.edu.bo/mruizo/wp-content/uploads/VDI2221.pdf>
- [49] Polyamides (PA). Retrieved from <http://www.ensinger-online.com/en/materials/engineering-plastics/polyamides/>
- [50] Polyjet Materials. Retrieved from <http://www.stratasys.com/materials/polyjet>

APPENDIX

- I. CD-disc
- II. Technical documentation
- III. Components for the prototype design
- IV. First prototype with two optically bonded PMMA plates (each 1.5 mm thick) and adhesive tape
- V. Second prototype with two optically bonded mineral glass plates (each 1 mm thick) and felt
- VI. Third prototype with foam tapes
- VII. Fourth prototype with thin film forming a “lip”
- VIII. Fifth prototype with rubber hose
- IX. Sixth prototype with labyrinth sealing
- X. Seventh prototype with spring steel
- XI. Eighth prototype with actuators on the backlight’s long sides
- XII. Final demonstrator

- II. Technical documentation
 - 1 Holder for Piezo actuator

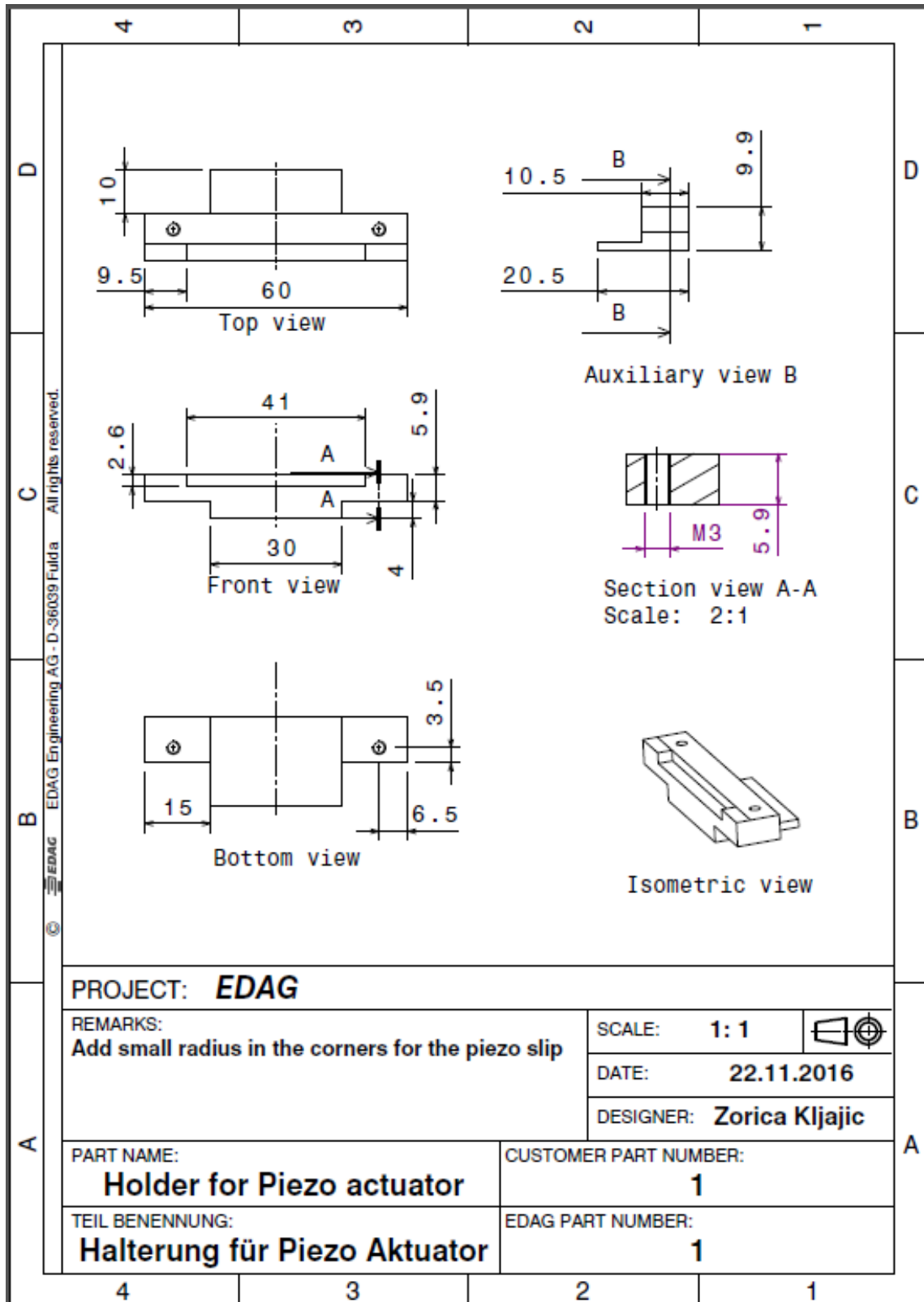

2 Labyrinth sealing

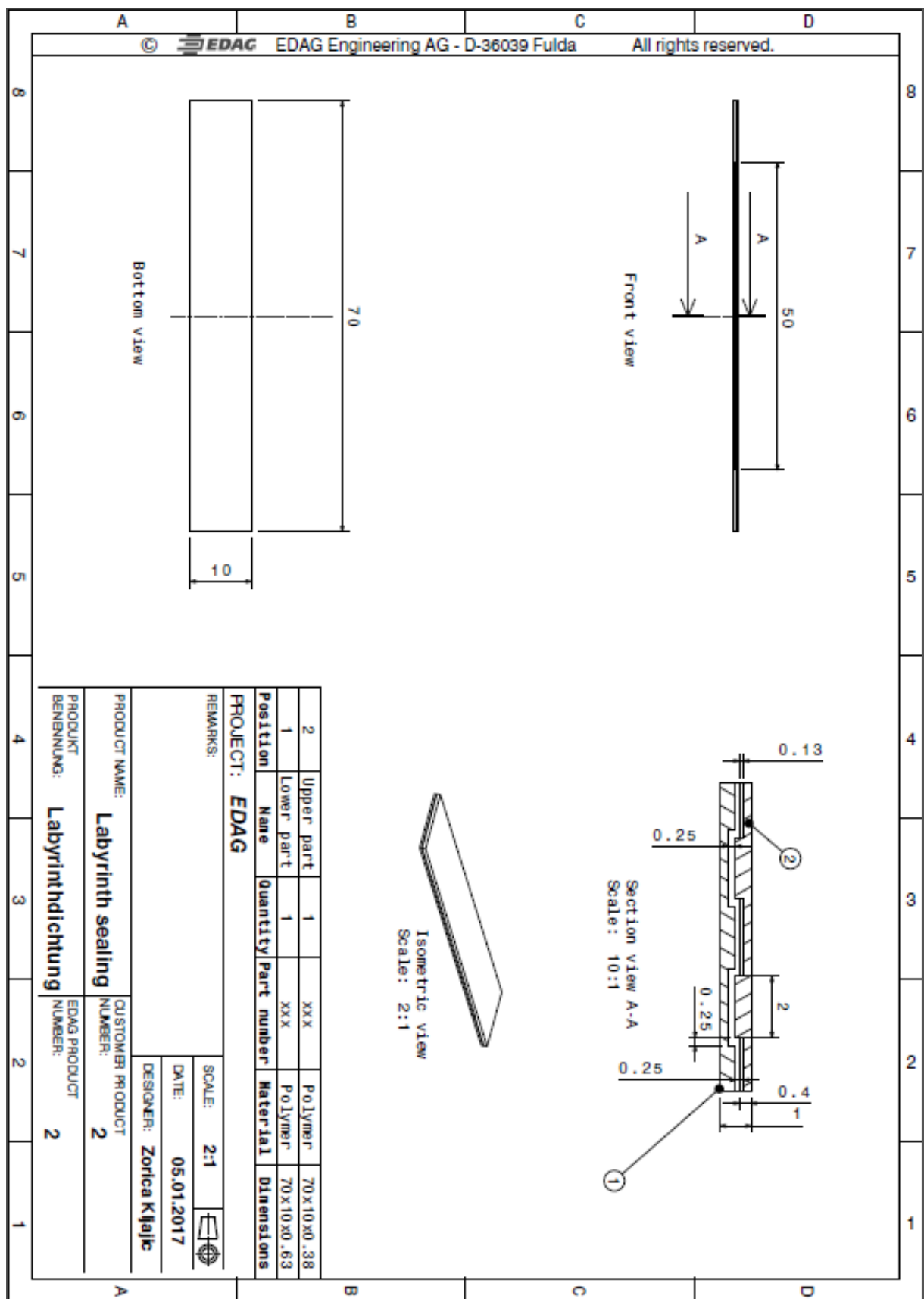

3 Lateral holder

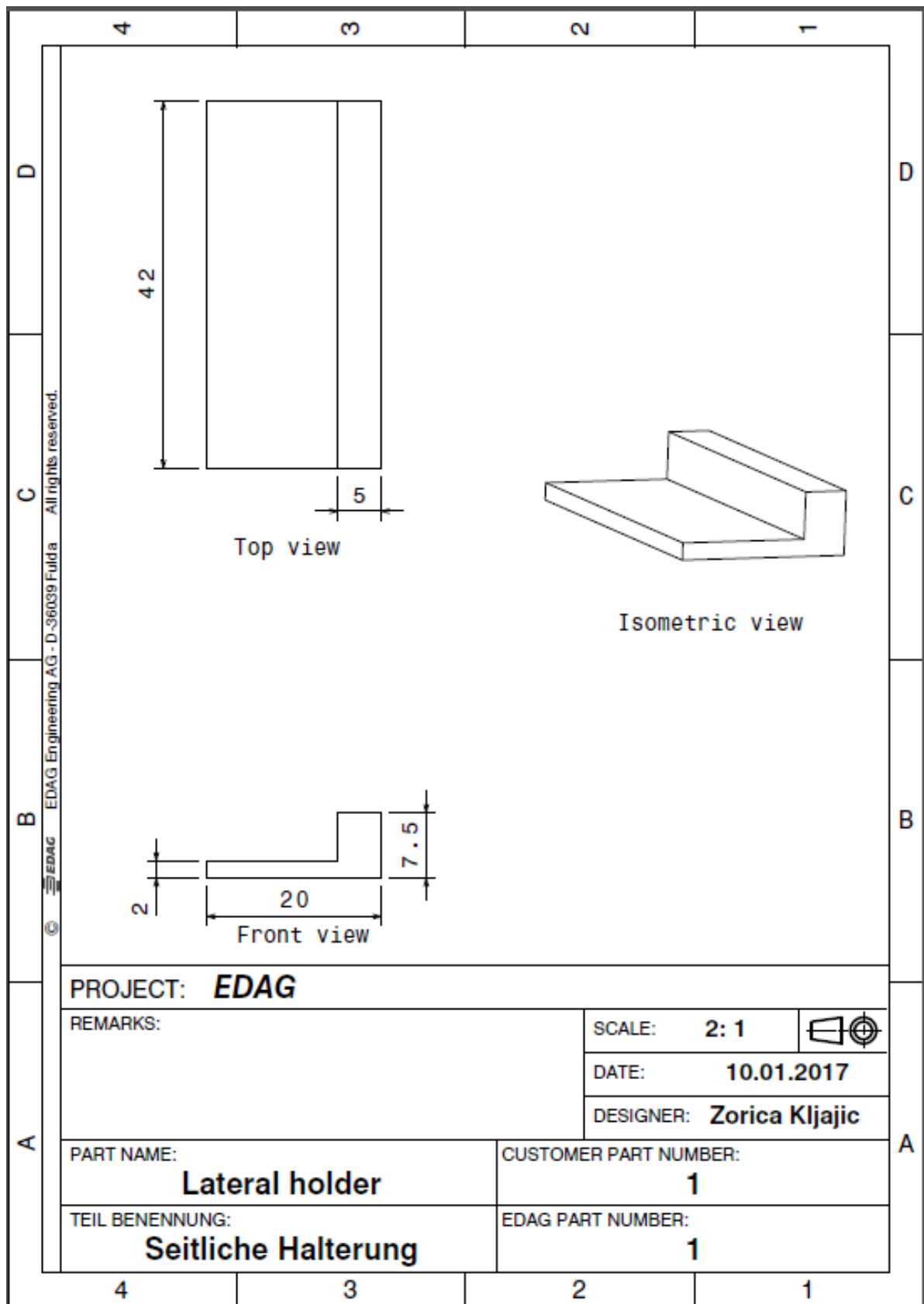

III. Components for the prototype design

- Piezoelectric actuator with three elastomer elements

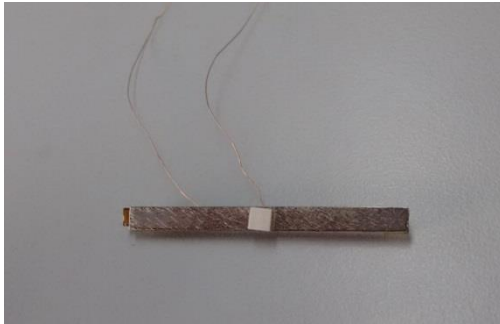

- Circuit board

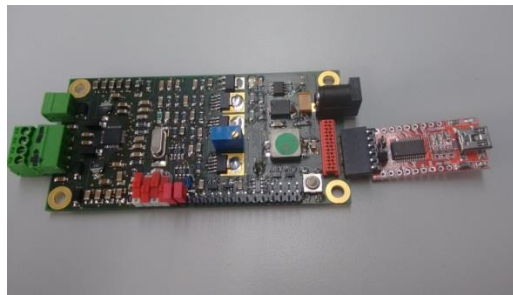

- Display



Whole display device with plastic frame



Separated backlight (used for the prototype)

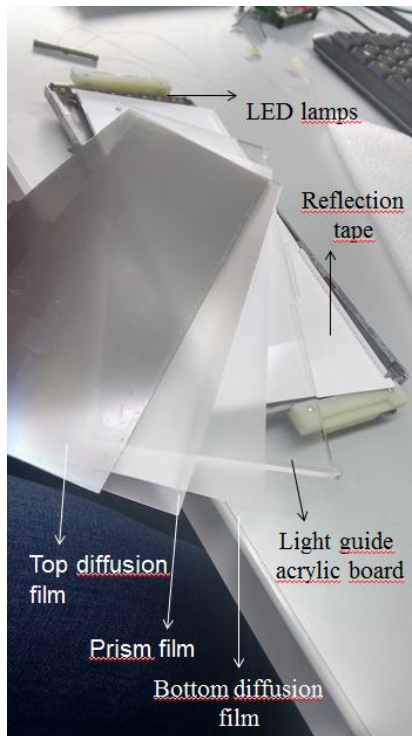

Backlight components



Cover glass glued to the plastic frame from the front
(Good representation of the display's active area;
enough space laterally for the holder)



Separated LCD and cover glass from the plastic frame



Visible tape on plastic frame after the cover glass is removed

- Additional equipment for first attempts



3M tape used for gluing the glass plate to the holder



Possible sealing element which might prevent overturning (foam rubber)

IV. First prototype with two optically bonded PMMA plates (each 1.5 mm thick)

- Pieces of adhesive tape dampened the vibration too much; the lump on the backlight disabled bending the cover plate in the center (blocked the small air gap between the plate and backlight which was left in order to allow the plate to be pushed in)

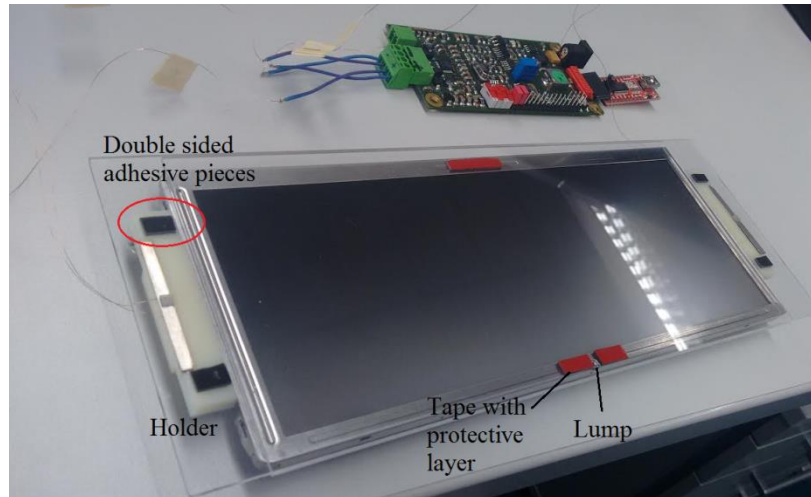

V. Second prototype with two optically bonded mineral glass plates (each 1 mm thick)

- Applied felt on the backlight's edge and two pieces of adhesive tape in the centre (after removing the lump)

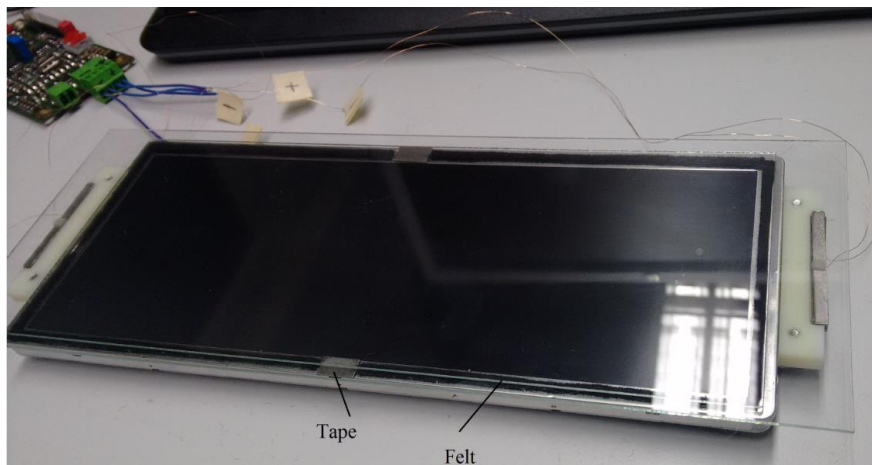

VI. Third prototype with foam tapes

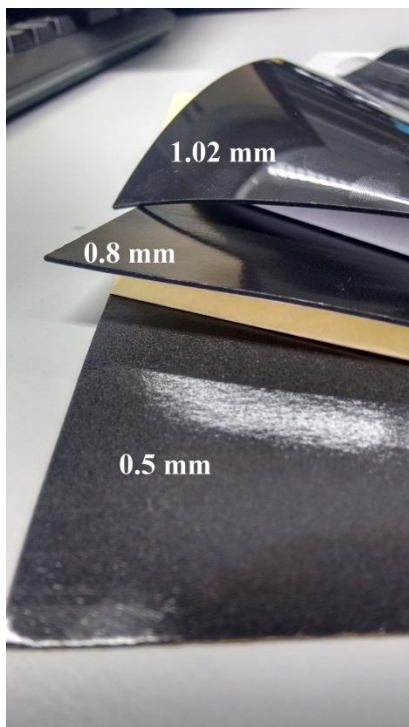

Three different samples (Tesa)



Prototype with 1.02 one-sided adhesive PUR foam tape

VII. Fourth prototype with thin film forming a “lip”

- Applied thin double-sided film forming a lip on each edge (dust might enter just in the four corners)



VIII. Fifth prototype with rubber hose

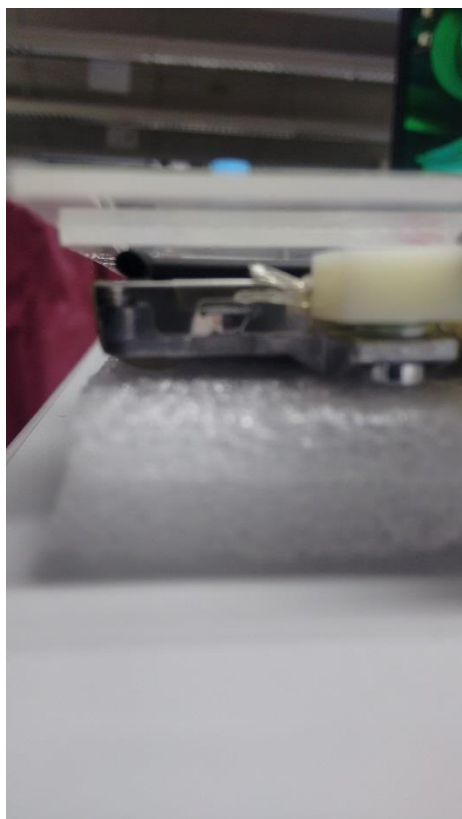

Visible hollow cable sleeve



Prototype with rubber cable sleeve

IX. Sixth prototype with labyrinth sealing

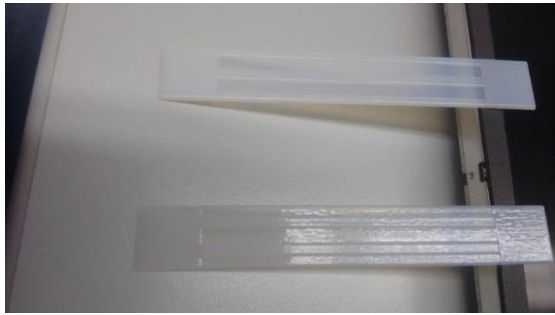

3D printed sealing (upper and lower part)

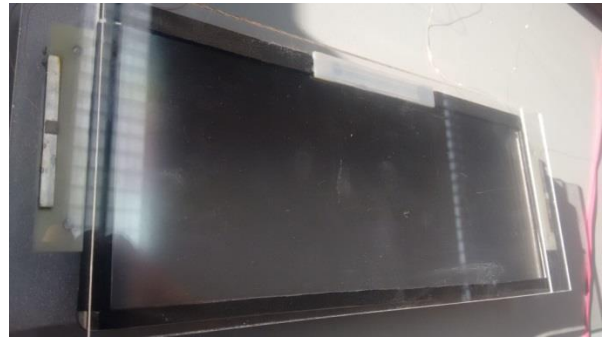

Glued parts of the sealing attached to the backlight from one side

X. Seventh prototype with spring steel

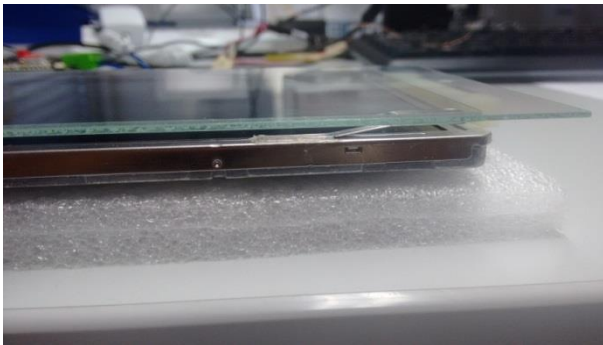

Close representation of one Z-shaped spring steel element in the corner



Prototype with four Z-shaped spring steel elements

XI. Eighth prototype with actuators on the backlight's long edges

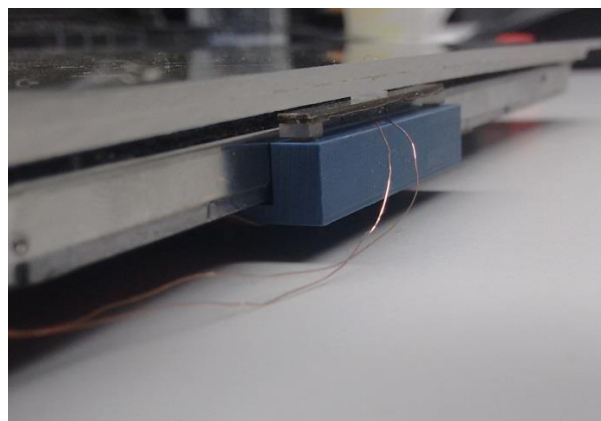

Milled holder (base Polyurethane, blue)

XII. Final demonstrator



3D printed housing and fills

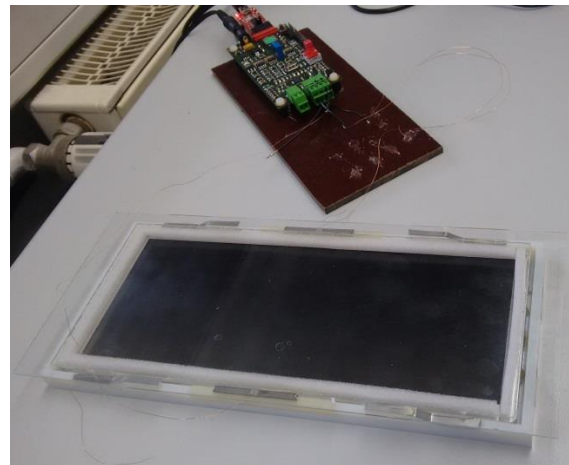

Final demonstrator