

# Sustav provjere stabiliteta i plovnosti malih plovila u skladu s normama ISO12217

---

**Prosinečki, Tomislav**

**Undergraduate thesis / Završni rad**

**2014**

*Degree Grantor / Ustanova koja je dodijelila akademski / stručni stupanj:* **University of Zagreb, Faculty of Mechanical Engineering and Naval Architecture / Sveučilište u Zagrebu, Fakultet strojarstva i brodogradnje**

*Permanent link / Trajna poveznica:* <https://urn.nsk.hr/urn:nbn:hr:235:656479>

*Rights / Prava:* [In copyright](#)/[Zaštićeno autorskim pravom.](#)

*Download date / Datum preuzimanja:* **2024-11-25**

*Repository / Repozitorij:*

[Repository of Faculty of Mechanical Engineering and Naval Architecture University of Zagreb](#)



SVEUČILIŠTE U ZAGREBU  
FAKULTET STROJARSTVA I BRODOGRADNJE

# ZAVRŠNI RAD

**Tomislav Prosinečki**

Zagreb, 2014.

SVEUČILIŠTE U ZAGREBU  
FAKULTET STROJARSTVA I BRODOGRADNJE

# ZAVRŠNI RAD

Mentor:

Prof. dr. sc. Izvor Grubišić, dipl. ing.

Student:

Tomislav Prosinečki

Zagreb, 2014.

Izjavljujem da sam ovaj rad izradio samostalno, koristeći znanja stečena tijekom studija i navedenu literaturu.

Prije svega veliko hvala mojoj obitelji na bezuvjetnoj podršci i neizmjernom strpljenju za vrijeme ovog dijela studija. Zahvaljujem se svojem mentoru prof. dr.sc Izvoru Grubišiću, dipl.ing, te predavaču Ivanu Muniću, dipl.ing. na svim korisnim savjetima koji su mi uvelike pomogli pri izradi ovog rada. Hvala i tebi Bože.

Tomislav Prosinečki



SVEUČILIŠTE U ZAGREBU  
**FAKULTET STROJARSTVA I BRODOGRADNJE**  
Središnje povjerenstvo za završne i diplomske ispite  
Povjerenstvo za završne i diplomske ispite studija brodogradnje



Sveučilište u Zagrebu Fakultet strojarstva i brodogradnje	
Datum	Prilog
Klasa:	
Ur.broj:	

## ZAVRŠNI ZADATAK

Student: **Tomislav Prosinečki**

Mat. br.:0035185258

Naslov rada na hrvatskom jeziku: **SUSTAV PROVJERE STABILITETA I PLOVNOSTI MALIH PLOVILA U SKLADU S NORMAMA ISO 12217**

Naslov rada na engleskom jeziku: **SYSTEM FOR STABILITY AND BUOYANCY ASSESSMENT OF SMALL CRAFT IN ACCORD WITH ISO 12217 NORMS**

Opis zadatka:

Potrebno je koncipirati i izraditi sustav za provjeru usklađenosti plovnosti i stabiliteta za tri kategorije malih plovila u skladu sa sljedećim normama:

Mala plovila – Ocjenjivanje i razredba stabilnosti i plovnosti – 1. dio:  
Mala plovila bez jedara duljine trupa 6 m ili više – Amandman 1  
(ISO 12217-1:2002/Amd 1:2009; EN ISO 12217-1:2002/A1:2009)

Mala plovila – Ocjena i razredba stabiliteta i plovnosti – 2. dio:  
Jedrilice duljine trupa 6 m ili više  
(ISO 12217-2:2002; EN ISO 12217-2:2002)

Mala plovila – Ocjenjivanje i razredba stabilnosti i plovnosti – 3. dio:  
Brodice duljine trupa manje od 6 m – Amandman 1  
(ISO 12217-3:2002/Amd 1:2009; EN ISO 12217-3:2002/A1:2009)

Sustav treba precizno definirati potrebne ulazne podatke kao i sve korake postupka provjere u obliku pogodnom za korisnika koji posjeduje temeljna znanja struke. Treba koristiti funkcije tabličnog kalkulatora, a po potrebi dodatno programirati posebne makro rutine. Tablični kalkulator treba oblikovati tako da se može dobiti kompletan ispis postupka kao i tablica izlaznih veličina sa svim potrebnim izrazima i formulama. Također je potrebno u sustav uključiti kratke upute za budućeg korisnika.

Funkcionalnosti sustava treba pokazati na primjeru jednog broda.

Literatura: Larsson & Eliasson: Principles of Yacht Design, Adlard Coles Nautical 2007

Zadatak zadan:

11. studenog 2013.

Rok predaje rada:

**1. rok:** 21. veljače 2014.

**2. rok:** 12. rujna 2014.

Predviđeni datumi obrane:

**1. rok:** 3., 4. i 5. ožujka 2014.

**2. rok:** 22., 23. i 24. rujna 2014.

Zadatak zadao:

Prof. dr. sc. Izvor Grubišić

Predsjednica Povjerenstva:

Prof. dr. sc. Nastia Degiuli

## SADRŽAJ

SADRŽAJ .....	I
POPIS SLIKA .....	II
POPIS TABLICA.....	III
POPIS OZNAKA .....	IV
SAŽETAK.....	V
SUMMARY .....	VI
1. UVOD.....	1
1.1. Smjernice za proračun stabilneta velikih brodova prema IS CODE 2008.....	3
2. PRORAČUN STABILITETA I PLOVNOSTI MALIH BRODOVA.....	6
2.1. Podjela plovila s obzirom na duljinu, oblik primarne propulzije i projektne kategorije.....	6
2.2. Osnovni zahtjevi i definicije .....	7
2.2.1. Osnovni pojmovi i definicije.....	8
2.3. Proračun motornih brodova prema normi HRN ISO 12217-1:2002.....	9
2.3.1. Downflooding openings (Naplavljivi otvori).....	10
2.3.2. Downflooding height (Visina naplavljivanja) .....	11
2.3.3. Downflooding angle $\Phi_D$ (Kut naplavljivanja).....	11
2.3.4. Offset-load test (pokus nagiba).....	12
2.3.5. Resistance to waves and wind (Inertnost prema utjecaju valova i vjetra ) .....	13
2.3.6. Heel due to wind action (Nagib uzrokovan vjetrom).....	14
2.3.7. Flotation requirements (Uvjeti plutanja).....	14
2.4. Proračun jedrilica prema normi HRN ISO 12217-2:2002 .....	15
2.4.1. Angle of vanishing stability $\phi_{V(R)}$ (Kut gubitka stabilnosti) .....	17
2.4.2. Stability index - STIX (Indeks stabilnosti) .....	18
2.4.3. Knock-down recovery test (Test polijeganja).....	19
2.4.4. Wind stiffness test.....	20
2.4.5. Capsize-recovery test (Test izvrtanja).....	21
2.4.6. Breaking waves .....	21
3. UPUTE KORISNIKU TABLIČNOG KALKULATORA .....	22
3.1. Općenito .....	22
3.2. Unos podataka.....	23
3.3. Završna uputa .....	24
4. ZAKLJUČAK.....	25
LITERATURA.....	26
PRILOZI.....	27

**POPIS SLIKA**

Slika 1.	Krivulja momenta statičkog stabiliteta i krivulja prekretnog momenta i krivulja prekretnog momenta.....	2
Slika 2.	Kombinirani utjecaj jakog vjetra i ljuljanja na stabilitet velikog broda.....	4
Slika 3.	Utjecaj valova i vjetra na mali brod .....	13
Slika 4.	Pravilno i nepravilno odabrane opcije.....	23
Slika 5.	Oznaka za proračun potrebne i nepotrebne tablice .....	23
Slika 6.	Zadovoljenje i nezadovoljenje proračunskih uvjeta .....	24
Slika 7.	Tehnički nedostatak.....	24

**POPIS TABLICA**

Tabela 1.	Značajke projektnih kategorija .....	7
Tabela 2.	Zahtjevani testovi .....	10
Tabela 3.	Zahtjevani kut naplavljivanja .....	12
Tabela 4.	Raspodjela zahtjeva po projektnim kategorijama jedrilica .....	16
Tabela 5.	Zahtjevani kut gubitka stabilnosti .....	17
Tabela 6.	STIX utjecajni faktori.....	18
Tabela 7.	Zahtjevana vrijednosti STIX-a .....	19
Tabela 8.	Zahtjevana brzine vjetra .....	20



## POPIS OZNAKA

Oznaka	Jedinica	Opis
$M_o$	[ m ]	početna metacentarska visina
$G$	[ m ]	težište sistema broda
$\phi$	[ ° ]	kut nagiba broda
$\phi_f$	[ ° ]	kut naplavljivanja
$GZ$	[ m ]	poluga statičkog stabiliteta
$l_{w1}$	[ m ]	poluga momenta konstantnog vjetra
$\Phi_0$	[ ° ]	ravnotežni kut pod djelovanjem stalnog vjetra
$\Phi_1$	[ ° ]	kut nagiba uslijed djelovanja valova i vjetra
$l_{w2}$	[ m ]	Poluga momenta naleta vjetra
$\Phi_2$	[ ° ]	kut naplavljivanja ili 50° ili $\Phi_c$ što je veće
$\Phi_c$	[ ° ]	kut kod sjecišta krivulje poluge momenta naleta vjetra i GZ krivulje
$A_s$	[ m <sup>2</sup> ]	nominalna površina jedara
$m_{LDC}$	[ kg ]	masa broda u punom stanju krcanja
$m_{MOC}$	[ kg ]	masa broda u minimalnom operativnom stanju krcanja
$\Phi_{v(R)}$	[ ° ]	zahtjevani kut gubitka stabilnosti
$L_H$	[ m ]	duljina trupa broda
$B_H$	[ m ]	proračunska širina broda
$L_{WL}$	[ m ]	duljina broda na vodnoj liniji
$F_M$	[ m ]	visina nadvođa na sredini broda
$v_w$	[ m/s ]	brzina vjetra

## SAŽETAK

Proračun stabiliteta i plovnosti kod malih plovila značajno je drugačiji nego li kod velikih brodova trgovačke mornarice. Zbog manje duljine, značajno nižeg nadvođa i mnogih otvora u samome trupu, manji brodovi izloženiji su utjecajima velikih valova, jakog vjetra i jačih stanja mora. Posljedično, brodski registri mala plovila, s obzirom na njihova konstrukcijska obilježja (ovisno o duljini i namjeni broda te primarnom načinu pogona), kategoriziraju u četiri skupine odnosno zone plovidbe: A (*Ocean*), B (*Offshore*), C (*Inshore*) i D (*Sheltered*). Većina modernih softverskih paketa u sebi ima ugrađena spomenuta pravila. Međutim, već u samoj preliminarnoj fazi osnivanja projekta, poželjno je imati alat koji će projektantu omogućiti brzu kontrolu pojedinih projektnih ideja. U ovome radu nastojao sam navedena pravila sistematično i što jednostavnije iskodirati u svima dostupnom obliku - obliku tabličnog kalkulatora. Na taj način korisniku je omogućen uvid u čitav postupak, a sam ispis dobivenih rezultata pregledan je i fleksibilian s obzirom na zahtjeve korisnika.

Ključne riječi: stabilitet; plovnost; rekreativna plovila; mali brodovi; motorni brodovi; jedrilice; ISO pravila.

## SUMMARY

Stability and buoyancy assessment of small craft significantly differs from large merchant ship assessment. Because of smaller dimensions, significantly smaller freeboard and many hull openings, small boats are more exposed to waves, strong wind and heavy seas effects. Consequently, according to their dimension, construction properties and prime propulsion, small boats are divided in four categories by the ISO Rules, as follows: A (*Ocean*), B (*Offshore*), C (*Inshore*) and D (*Sheltered*). Although most of modern software tools already have the Rules implemented by default, sometimes it is very useful, particularly in preliminary approach, to have a tool that will help designer to evaluate new project ideas rapidly. In this thesis my goal was to systematically and simply transform written rules into program form available to everyone – table calculator form. Thus calculator user is supplied with whole calculation procedure and also the print of accomplished results is descriptive and flexible according to user demands.

Key words: boat stability; boat flotation; recreational craft; small craft; motor boats; sailing boats; ISO rules.

## 1. UVOD

*“Navigare necesse est, vivere non est necesse”*

(Pompej Veliki 106. - 48. g. pr. Kr)

Navedena latinska poslovice (u doslovnom prijevodu *Ploviti se mora, živjeti se ne mora*) poznata je gotovo svima. Svi ćemo se složiti da je ne smijemo shvatiti doslovno, međutim rijetki će se upustiti u dublju analizu izrečenoga. Oni skloniji filozofskim raspravama pozabavit će se drugim dijelom rečenice, a istinski zaljubljenici u more i brodove zadržat će se na prvome dijelu.

Osnovni zahtjevi koje brod mora zadovoljiti da bi se održao na mirnoj vodi u uspravnom položaju i pod punim opterećenjem zovu se uvjeti plovnosti. Kod broda razmatramo tri uvjeta plovnosti:

1. Težina tijela koje pluta na površini vode jednaka je sili uzgona koja na to tijelo djeluje, odnosno jednaka je težini tekućine koju je to tijelo istisnulo.
2. Duljina koja spaja težište sistema broda i tereta sa težištem istisnine okomita je na vodnu liniju.
3. Metacentar  $M_0$  mora ležati iznad težišta sistema  $G$ , odnosno metacentarska visina mora biti pozitivna (uvjet stabilne ravnoteže)

Navedeni uvjeti vrijede samo za male kutove nagiba broda, odnosno govorimo o stabilitetu broda u uspravnom položaju. Budući da u obzir uzimamo samo male kutove nagiba (položaj točke metacentra smatramo konstantnim), govorimo o početnom metacentru i početnoj metacentarskoj visini.

Također da bi zadovoljio svoju funkciju transporta, brod se mora oduprijeti svim vanjskim poremećajima koji nastoje brod izbaciti iz ravnotežnog položaja. Budući da vjetar i valovi, a ponekad i premještanje tereta, brod naginju za veće kutne vrijednosti, već spomenuta tri uvjeta plovnosti nisu više dovoljna. Naime, kod većih kutova nagiba, stvarni metacentar nalazi se niže od početnog metacentra i njegov položaj stalno se mijenja. Prikaz stvarnih metacentarskih visina ovisno o kutu nagiba broda prikazujemo u dijagramu krivulje momenta statičkog stabiliteta.

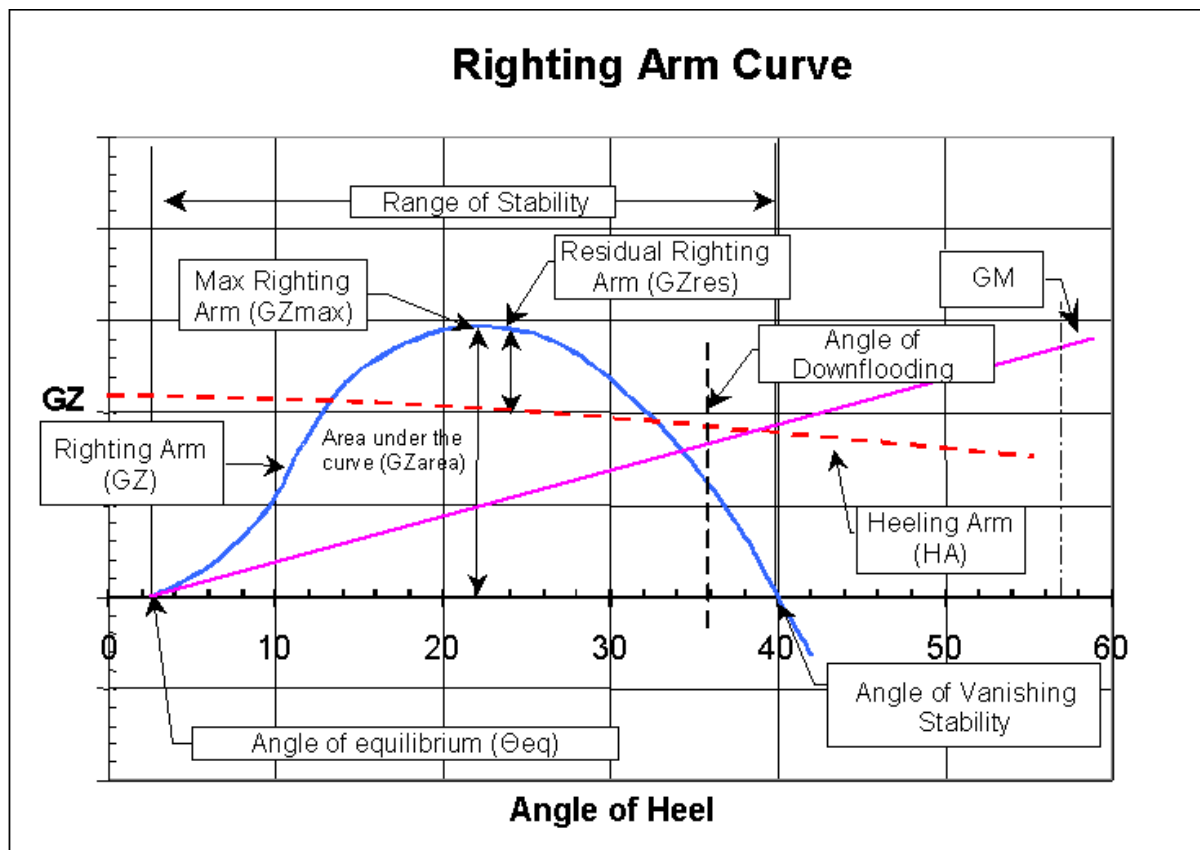

**Slika 1. Krivulja momenta statičkog stabiliteta i krivulja prekretnog momenta i krivulja prekretnog momenta [www.tc.gc.ca]**

Iako stabilitet predočujemo veličinom metacentarske visine, ključnu ulogu u stavrnosti igraju momenti, točnije moment statičkog stabiliteta i moment prekretanja. Naime, sve dok je moment prekreta veći od momenta statičkog stabiliteta, kut nagiba broda će se povećavati. Nakon trenutka kada momenti budu uravnoteženi, za infinitezimalno povećanje kuta nagiba, statički moment stabiliteta postaje veći, i brod se vraća prema početnom ravnotežnom položaju. Sve navedeno vrijedi u slučaju sporih promjena. U slučaju naglih promjena, kada ubrzanja mase ne možemo zanemariti, govorimo o dinamičkom djelovanju sila, odnosno o dinamičkom stabilitetu broda. U ovome razmatranju ključnu ulogu imaju radovi sila. Uslijed nastalog ubrzanja brod dobiva brzinu gibanja, koja se za vrijeme djelovanja prekretnog momenta povećava. Zbog nastale kinetičke energije mase broda, on se ne može zaustaviti u statičkom položaju ravnoteže, već se nastavlja nagibati, sada usporeno, sve do točke u kojoj će kinetička energija biti neutralizirana radom statičkog momenta. Kako radove možemo prikazati kao površine ispod krivulja momenata, to će se dogoditi u trenutku kada će se površine između krivulja momenata prekretanja i statičkog stabiliteta izjednačiti.

Budući da u stvarnim proračunima brodova radimo sa složenim brodskim formama, kao i složenim vanjskim opterećenjima, ručno računanje svakog pojedinog slučaja bilo bi predugotrajno. Stoga, u današnje vrijeme koristimo se računalima i softverskim alatima koji nam uvelike ubrzavaju posao. Također, na temelju znanstvenog proučavanja i godina iskustva plovidbe, brodski registri danas izdaju pravila koja nam daju smjernice za provedbu potrebnih proračuna i propisuju zahtjevane vrijednosti karakteristika brodske forma.

Tablični proračun u ovome zadatku izrađen je prema europskoj normi *Small craft – Stability and buoyancy assessment and categorization (ISO 12217:2002)*, od strane Državnog zavoda za normizaciju i mjeriteljstvo usvojenoj kao *Mala plovila – Ocjena i razradba stabiliteta i plovnosti (HRN ISO 12217:2002)*.

### 1.1. Smjernice za proračun stabiliteta velikih brodova prema IS CODE 2008

Svrha propisa je predstaviti zakonske i preporučene zahtjeve na stabilitet broda i ostale mjere koje doprinose sigurnoj eksploataciji broda, smanjenju rizika sigurnosti tijekom plovidbe za brod, posadu i okolinu. [2008 IS CODE] Pravila se odnose na stabilnost neoštećenog broda i svih pomorskih prometala duljine veće od 24 m, a uključuju teretne, putničke, ribarske, kontejnerske brodove, brodove specijalnih namjena, brodove za opskrbu pučinskih objekata, te pokretne pučinske bušee jedinice.

Osim standardnog proračuna centracije za svako pojedino stanje krcanja broda i određivanja težišta sistema nakrcanog broda, pravila propisuju i određene zahtjeve na svojstva krivulje poluge stabiliteta kako slijedi:

- Površina ispod krivulje momenta statičkog stabiliteta ne smije biti manja od 0,055 m rad do kuta nagiba  $\varphi = 30^\circ$ , i ne manja od 0,09 m rad do kuta nagiba  $\varphi = 40^\circ$  ili kuta naplavlivanja  $\varphi_D$  ukoliko je taj kut manji od  $40^\circ$ . Također, površina ispod krivulje statičkog momenta između kutova nagiba od  $30^\circ$  i  $40^\circ$ , ili  $30^\circ$  i  $\varphi_D$  (ukoliko je  $\varphi_D$  manji od  $40^\circ$ ), ne smije biti manja od 0,03 m rad.
- Poluga stabiliteta  $GZ$  po iznosu mora biti jednaka ili veća 0,2 m pri kutu nagiba od  $30^\circ$  ili većem.

- Maksimalna vrijednost poluge stabiliteta mora se pojavljivati pri kutu nagiba ne manjem od  $25^\circ$ . Ukoliko ovaj zahtjev nije moguće postići, alternativni zahtjev u pogledu jednake razine sigurnosti može biti posebno odobren od strane nadležne institucije.
- Početna metaentarska visina ne smije biti manja od 0,15 m.

Također, sposobnost broda da podnese vanjske utjecaje loših vremenskih uvjeta, točnije kombiniranog utjecaja bočnog vjetrova i izraženog valjanja broda definirana je sljedećim uvjetima, u skladu sa Slikom 2.:

- Brod je izložen stalnom pritisku vjetrova koji djeluje okomito na uzdužnu simetralnu ravninu broda, što rezultira stalnom polugom momenta vjetrova ( $l_{w1}$ )
- Od kuta nagiba u ravnotežnom stanju ( $\varphi_0$ ), pretpostavlja se da se brod, zahvaljujući djelovanju valova, ljulja do kuta valjanja ( $\varphi_1$ ) u privjetrini. Kut nagiba uslijed konstantnog vjetrova ( $\varphi_0$ ) ne smije prijeći vrijednost od  $16^\circ$  ili 80% kuta pri kojem Paluba uranja, ovisno koji je veći.
- Brod je potom izložen naletu vjetrova koji rezultira polugom momenta nagiba ( $l_{w2}$ );
- U navedenim uvjetima, površina  $b$  nesmiye biti manja od površine  $a$ , kao što je prikazano na slici.

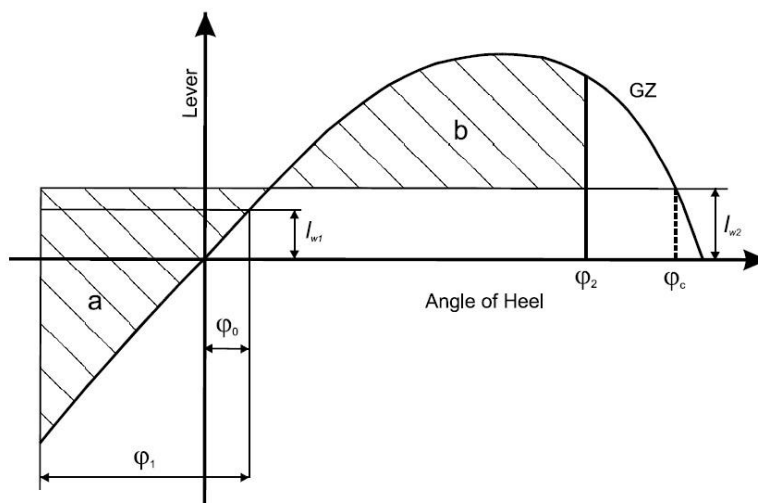

**Slika 2. Kombinirani utjecaj jakog vjetrova i ljuljanja na stabilitet velikog broda, [IS CODE 2008]**

gdje je:

$\varphi_2$  = kut naplavljivanja  $\varphi_D$  ili  $50^\circ$  ili  $\varphi_c$ , što je veće

$\varphi_c$  = kut pri drugom sjecištu krivulje poluge momenta naleta vjetra i *GZ* krivulje

Pri tome poluge momenata nagiba vjetra  $l_{w1}$  i  $l_{w2}$  treba smatrati konstantnim vrijednostima za sve kutove nagiba, a kao i kut nagiba pri valjanju  $\varphi_1$ , računaju se prema formulama navedenim u pravilima.

Alternativne metode određivanja poluge momenta nagiba mogu biti prihvaćene, ako su odobrene od strane nadležne institucije. Pri određivanju poluga ekperimentalnim metodama brzinu vjetra treba uzeti u iznosu od 26 m/s sa ujednačenim profilom brzine.



## 2. PRORAČUN STABILITETA I PLOVNOSTI MALIH BRODOVA

### 2.1. Podjela plovila s obzirom na duljinu, oblik primarne propulzije i projektne kategorije

*HRN ISO 12217:2002 Mala plovila – Ocjena i razradba stabiliteta i plovnosti* (u nastavku *Pravila*) norma koja je korištena kao osnova za izradu ovog rada obuhvaća plovne jedinice duljine od 6 m do 24 m, a s obzirom na oblik primarne propulzije i proračunsku duljinu dijeli ih na:

- Mala plovila bez jedara duljine trupa 6 m ili više (*HRN ISO 12217-1:2002*)
- Jedrilice duljine trupa 6 m ili više (*HRN ISO 12217-2:2002*), te
- Brodice duljine trupa manje od 6 m (*HRN ISO 12217-3:2002*)

Cilj provedbe ovog proračuna je, s obzirom na fizikalna svojstva broda i ponašanje u određenim vremenskim uvjetima, brodu dodijeliti projektну kategoriju, odnosno propisati zonu plovidbe za koju je brod projektiran. S obzirom na očekivane vremenske uvjete i geografske osobine područja plovidbe, *Pravila* propisuju četiri kategorije plovila:

- **Kategorija A** (Ocean) – brod je projektiran za službu pri vjetru jačine do 10 Bf ili manje uz pripadajuće značajne valne visine, i za preživljavanje u jačim vremenskim neprilikama. Ovakve vremenske prilike mogu se očekivati na dugim putovanjima, primjerice prekooceanskim, ali i u priobalnim, od valova i vjetra nezaklonjenim područjima, nekoliko stotina milja udaljenim od kopna. Očekivani naleti vjetra mogu biti do 28 m/s.
- **Kategorija B** (Offshore) – brod je projektiran za valove značajne valne visine do 4 m i vjetar jakosti do 8 Bf. Ovakvi vremenski uvjeti mogu se susresti na obalnim putovanjima ili u priobalnim područjima gdje zaklon nije uvijek dostupan. Slični uvjeti također mogu se sresti u užim priobalnim vodama većih mora. Očekivana brzina vjetra u naletima iznosi 21 m/s.
- **Kategorija C (Inshore)** – brod je projektiran za valove do 2 m značajne valne visine i stalne vjetrove jačine do 6 Bf ili manje. Opisani uvjeti karakteristični su za uže prioblane vode, ušća te širi priobalni pojas u umjerenim vremenskim uvjetima. Očekivani naleti vjetra brzine su do 17 m/s.

- **Kategorija D (Sheltered)** – brod je projektiran za uobičajene valove do 0,5 m visine i stalnu jačinu vjetra do 4 Bf. Navedeni uvjeti vladaju u zaklonjenim priobalnim vodama te u obalnom području tijekom lijepog vremena. Očekivani naleti vjetra mogu dosegnuti brzinu do 13 m/s

gdje je značajna valna duljina definirana kao srednja vrijednost trećine najviših valova, što približno odgovara procjeni trenutne stvarne valne visine iskusnog promatrača. Rijetki valovi mogu dosegnuti visinu i dvostruku od navedene.

**Tabela 1. Značajke projektnih kategorija**

Projektna kategorija	A	B	C	D
Visina vala do	oko 7 m značajne	4 m značajne	2 m značajne	0,5 m maksimalne
Jačina vjetra u [Bf]	do 10	do 8	do 6	do 4
Proračunska brzina vjetra u [m/s]	28	21	17	13

## 2.2. Osnovni zahtjevi i definicije

Ovisno o kategoriji i značajkama plovila potrebno je provesti određene proračune i pokuse kako bi se zadovoljili projektni zahtjevi *Pravila* i dokazalo da je brod sposoban podnijeti određena projektna opterećenja koja ga očekuju u službi. Prije samog proračuna, ovisno o konstrukcijskom rješenju palube (*fully decked boat* - vodonepropustna paluba s nadgrađem iznad vodne linije tijekom eksploatacije; *partially decked boat* – barem dvije trećine horizontalne bočne projekcije razme prekriveno je palubom, nadgrađem ili kućicom koja je vodonepropustna), potrebno je odabrati i željenu opciju proračuna. Također, za kategorije A i B, i određene značajke broda potrebno je pokuse i proračune provesti za dva krajnja načina krcanja:

- *loaded displacement condition* (u masu lakog broda uključeno je puno opterećenje opreme, puni kapaciteti svih tekućina npr. balastni tankovi, pitka voda, ulje ..., masa cijele posade sa svim osobnim potrepštinama)
- *minimum operating condition* (masa lakog broda s uključenim minimalnim brojem članova posade, osnovnom opremom za spašavanje, opremom koja je stalno na brodu, punim balastnim tankovima koji su predviđeni da budu u upotrebi tijekom plovidbe i splavi za spašavanje pozicioniranom na predviđenom mjestu)

Konačan prikaz zahtjevanih testova ovisno o načinu pogona broda prikazan je u Tabeli 2. (motorni brodovi) te Tabeli 3. (jedrilice).

### 2.2.1. Osnovni pojmovi i definicije

Design category (Projektna kategorija) – opis stanja mora i vjetra za koja je brod projektiran

Sailing boat (Jedrilica) – brod čiji je primarni oblik pogona vjetar i zadovoljava uvjet

$$A_s \geq 0,07(m_{LDC})^{2/3}$$

Catamaran (Katamaran) – brod sa dva trupa opterećena projektnim opterećenjem

Fully decked boat – brod čija horizontalna projekcija razme uključuje bilo koju kombinaciju:

- Vodonepropustne palube i nadgrađa, i/ili
- Brzo-praznećeg upuštenja u skladu s ISO 11812, i/ili
- Vodonepropustno upuštenje u skladu s ISO 11812 s ukupnim kombiniranim volumenom ne manjim od  $L_H B_H F_M / 40$

Downflooding opening (Naplavljivi otvor) – bilo koji otvor koji može propustiti vodu u unutrašnjost ili kaljužu, ili upuštenje, osim vodonepropustnih

Downflooding angle (Kut naplavljivanja)  $\phi_D$  – kut nagiba pri kojem naplavljivi otvor biva uronjen, za vrijeme mirnih vremenskih uvjeta i za odgovarajuće stanje krcanja i trim

Downflooding height (Visina naplavljivanja)  $h_D$  – najmanja visina iznad vodne linije do najnižeg naplavljivog otvora osim vodonepropustnih, za uspravan brod u mirnim uvjetima pod punim opterećenjem i sa projektnim trimom

Freeboard amidship (nadvođe)  $F_M$  - udaljenost razme ili palube od vodne linije na polovini duljine broda, kada je brod uspravan, za određeno stanje krcanja i projektni trim

Nominal sail area  $A_S$  (Nazivna površina jedara) – nazivna projicirana površina profila jedara u skladu s ISO 8666

Angle of vanishing stability (Kut gubitka stabilnosti)  $\phi_v$  – kut nagiba najbliži uspravnom (i različit od uspravnog) za određeno stanje krcanja pri kojem je moment poprečnog stabiliteta jednak nuli (v. Sliku 1.)

### **2.3. Proračun motornih brodova prema normi HRN ISO 12217-1:2002**

U naslovu navedena norma primjenjiva je na plovila pokretana ljudskom ili mehaničkom snagom od 6 m do 24 m duljine. Također, primjenjiva je i na brodove kraće od 6 m ukoliko zadovoljavaju osnovne zahtjeve ove norme. Suprotno tome, ova norma isključuje:

- plovila na napuhavanje duljine do 8 m (*ISO 6185*)
- kanue, kajake i ostale brodove širine manje od 1,1 m
- hidrokrilce i vozila na zračni jastuk, te
- podmornice

Također, u obzir nisu uzete ni radnje poput vuče, ribarenja, kopanja dna, podizanja i sl., koje treba posebno ispitati ukoliko je potrebno.

Pokusi i testovi u nastavku sastavni su dio proračuna plovnosti i stabiliteta datog u prilogu i ovdje će biti samo opisani informativno. Detaljni zahtjevi i propisi dani su i opisani u samim *Pravilima*. Tabela 2. prikazuje pokuse koje je potrebno provesti s obzirom na odabranu opciju kako bi plovilo udovoljilo zahtjeve za određenu kategoriju.

**Tabela 2. Zahtjevani testovi**

OPCIJA	1	2	3	4	5	6
Moguća kategorija	A i B	C i D	B	C i D	C i D	C i D
Izvedba plaube	Neprekinuta	Neprekinuta	Svejedno	Svejedno	Djelomično neprekinuta	Svejedno
Downflooding openings	X	X	X	X	X	X
Downflooding height test	X	X	X	X	X	X
Downflooding angle	X	X	X	X		
Offset-load test	X	X	X	X	X	X
Resistance to waves + wind	X		X			
Heel due to wind action		X		X	X	X
Flotation requirements			X	X		
Flotation material			X	X		

### 2.3.1. Downflooding openings (Naplavljivi otvori)

Ovim zahtjevom želi se utvrditi da ne postoji vodopropusti otvor na samome trupu ili nadgrađu plovila, koji tijekom plovidbe može biti uronjen pod vodu, i koji je potencijalna opasnost naplavljivanju unutrašnjosti broda. Zahtjev se odnosi na sve otvore osim onih vodonepropustnih, upuštenja s brzom odvodnjom naplavljenog mora, otvora u trupu koji su stalno zatvoreni, otvora u boku nadgrađa koji tijekom plovidbe moraju biti zatvoreni i koji su označeni posebnom oznakom te navedeni u korisničkom priručniku, te ispušnih organa motora koji su vodonepropustni. Svi navedeni elementi moraju biti izvedeni u skladu s normom *ISO 12216*. Također, niti jedan element otvora ne smije biti na visini manjoj od 0,2 m iznad vodne linije, osim posebnih slučajeva navedenih u *Pravilima*.

Iako postoji sličan zahtjev (minimalna visina nadvođa) u proračunu stabiliteta velikih trgovačkih brodova, ovaj zahtjev je rijetko relevantan jer u trupu velikog broda rijetko ili gotovo nikad ne susrećemo otvore u blizini vodne linije koji su prijetnja naplavljivanju. Također radi velikih dimenzija broda, nemoguće je pokus provesti u stvarnosti.

### 2.3.2. *Downflooding height (Visina naplavlivanja)*

Cilj ovog testa je utvrditi da brod posjeduje zadovoljavajuću visinu nadvođa pod punim projektnim opterećenjem prije nego li je nastupilo naplavlivanje. Proračun se se može provesti praktično, kao test uz pomoć utega težine po 75 kg ili ljudi odgovarajuće težine, ili računski.

Praktični dio provodi se u mirnim vremeskim uvjetima pod punim opterećenjem te uz raspored posade na način da se postigne projektni trim broda. Mjeri se visina iznad vodne linije do prvog mogućeg otvora naplavlivanja.

Zahtjevi koje je potrebno zadovoljiti mogu se izračunati na temelju duljine broda (Prilog 1.; Radni list 4.) ili prema metodi opisanoj u *ANNEX-u A* priloženom *Pravilima* (proračunske tablice priložene u Prilogu 1.; Radni list 2.)

Ovaj zahtjev postoji i u proračunu velikih trgovačkih brodova, međutim on se ne provodi pokusom već proračunom iz nacrtu linija broskog trupa.

### 2.3.3. *Downflooding angle $\Phi_D$ (Kut naplavlivanja)*

Zahtjev želi potvrditi da postoji dovoljno sigurnosne rezerve tijekom nagibanja broda prije nego li značajnija količina vode može ugroziti sigurnost broda.

Proračun se može provesti teoretskim putem (iz nacrtu brodskih linija pomoću odgovarajućeg programskog alata) ili približnom metodom navedenom u *ANEX-u C* u *Pravilima*. Ovisno o predviđenim projektnim stanjima krcanja, proračunu je potrebno pristupiti za dva slučaja. Ukoliko omjeri masa za dva suprotna načina krcanja  $m_{LDC}/m_{MOC} > 1,15$ , potrebno je razmotriti oba slučaja, inače samo za  $m_{MOC}$ . Najmanje dozvoljene vrijednosti kutova naplavlivanja kao funkcija projektnih kategorija dane su u tablici u nastavku (v. Tabela 3.)

Zbog velike mase, a posljedično i inercije velikih brodova, većina valova nije u mogućnosti dovoljno nagnuti brod da bi se dosegao kut naplavlivanja. Međutim, kod velikih brodova potrebno je promatrati interferenciju valova, odnosno potrebno je pod svaku cijenu izbjeći moguću pojavu rezonancije.

**Tabela 3. Zahtjevani kut naplavljivanja**

Projektna kategorija	Minimalni kut naplavljivanja [°]	
	Uzeti veću veličinu od dvije navedene	
A	$\Phi_0 + 25$	30
B	$\Phi_0 + 15$	25
C	$\Phi_0 + 5$	20
D	$\Phi_0$	

$\Phi_0$  – kut nagiba tijekom pokusa nagiba (offset-load test)

#### 2.3.4. Offset-load test (pokus nagiba)

Proračun se također može provesti praktičnim ili proračunskim (teoretskim) putem. Svrha pokusa je dokazati da će brod zadržati zadovoljavajuću stabilnost pri punom projektnom stanju krcanja, u slučaju premještanja posade na najnepovoljniji mogući način (maksimalni dozvoljeni broj članova posade prijeđe na isti bok broda). Praktični ili teoretski proračun provodi se drugačije za jednopalubne ili više palubne brodove, a detalji provođenja opisani su u ANNEX-u B u sklopu *Pravila*. Također u obzir treba uzeti i visoko pozicionirane terete na brodu (npr. jarboli, radarske antene i sl.) koji zbog velike poluge tijekom nagibanja, značajno mogu utjecati na rezultate pokusa.

Najveći dopušteni kut nagiba definiran je izrazom:

$$\Phi_{0(R)} = 10 + \frac{(24 - L_H)^3}{600} \quad (1)$$

Situacija navedena u pokusu, za veliki trgovački brod najčešće je zanemariva. Pomak mase nekoliko članova posade za red veličine širine broda od zanemarivog je značaja s obzirom na masu broda. Međutim u slučaju velikih putnički broda proračun se provodi za slučaj da veći broj ljudi pređe na jednu stranu broda.

### 2.3.5. Resistance to waves and wind (Inertnost prema utjecaju valova i vjetra )

Navedeni proračun djeli se na dva zahtjeva: *Valjanje u uvjetima bočnih valova i bočnog vjetra* te *Otpornost na utjecaje vjetra*. Također, ukoliko omjeri masa za dva suprotna načina krcanja  $m_{LDC}/m_{MOC} > 1,15$ , potrebno je razmotriti oba slučaja, inače samo za  $m_{MOC}$ . Za projektne kategorije A i B, ukoliko je površina upuštenja u palubi veća od dozvoljene (zbog mogućnosti zadržavanja veće količine vode i efekta slobodne površine), potrebno je provesti dodatne proračune.

Zahtjev *valjanja broda u uvjetima bočnih valova i bočnog vjetra*, slično kao i kod velikih brodova, ima za cilj provjeriti hoće li spregnuto djelovanje dviju prirodnih pojava utjecati na stabilnost broda. Za provođenje pokusa potrebno je poznavati krivulju momenta statičkog stabiliteta do kuta naplavljivanja, kuta gubitka stabilnosti ili  $50^\circ$ ; što je manje. Izrazi za računanje momenta prekretanja i posljedično kuta nagiba broda dani su u *Pravilima* pod točkom 6.3.2.

Također kao i kod velikih trgovačkih brodova, postavlja se uvjet odnosa površina ispod krivulja momenata statičkog stabiliteta broda i momenta prekretanja (v. Slika 3).

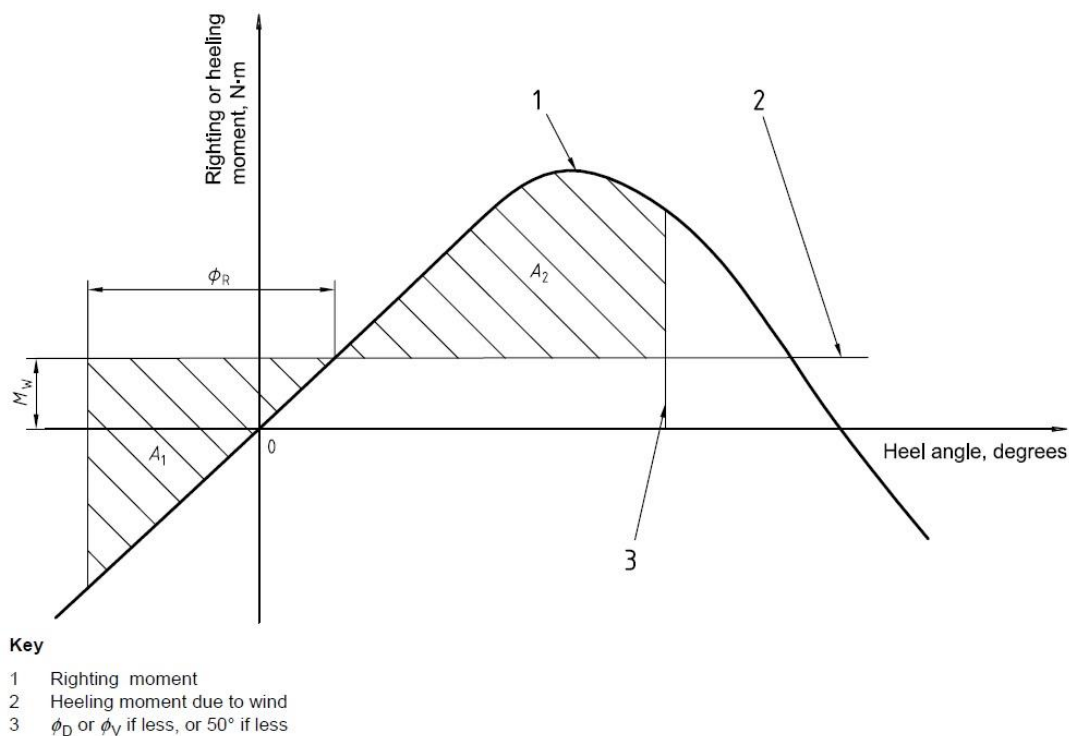

Slika 3. Utjecaj valova i vjetra na mali brod



Uvjet *otpornosti na utjecaje vjetra* zahtjeva da ukoliko se maksimalni moment stabiliteta javlja pri vrijednostima kuta nagiba većim ili jednakim  $30^\circ$ , on ne smije iznositi manje od 25 kNm za projektnu kategoriju A, odnosno 7 kNm za projektnu kategoriju B. Također, poluga statičkog stabiliteta po iznosu mora biti veća iki jednaka 0,2 m. Ukoliko se maksimalni moment stabiliteta javlja pri vrijednostima kuta nagiba manjim od  $30^\circ$  tada on mora zadovoljavati vrijednost  $(750/\phi_{GZmax})$  [kNm] za A kategoriju, odnosno  $(210/\phi_{GZmax})$  [kNm] za kategoriju B. Također, maksimalna poluga statičkog stabiliteta ne smije biti manja od iznosa dobivenog izrazom  $(6/\phi_{GZmax})$  [m].  $\phi_{GZmax}$  je kut nagiba u stupnjevima pri kojem se javlja najveći moment stabiliteta.

### **2.3.6. *Heel due to wind action (Nagib uzrokovan vjetrom)***

Navedeni zahtjev odnosi se samo na brodove željene projektne kategorije C i D, koji zbog svojih karakteristika nisu sposobni podnijeti jače vremenske uvjete. Pravila propisuju zahtjevani moment vjetra koji brod mora izdržati i ostati neoštećen. Također, ukoliko omjeri masa za dva suprotna načina krcanja  $m_{LDC}/m_{MOC} > 1,15$ , potrebno je razmotriti oba slučaja, inače samo za  $m_{MOC}$ .

Iako bočni vjetar kod velikih brodova ima utjecaj na stabilitet i posebno upravljivost broda, gotovo nikada se operativnost broda ne dovodi u opasnost samo zbog vjetra. Poseban slučaj opet su putnički brodovi koji imaju visoko nadgrađe i veliku izloženu površinu vjetru.

### **2.3.7. *Flotation requirements (Uvjeti plutanja)***

Cilj zadnjeg testiranja zahtjevanog za motorna plovila je dokazati da u slučaju uranjanja dijela palube i naplavljivanja unutrašnjosti plovila u trajanju najdulje pet minuta, brod ostaje plutati sa minimalno dvije trećine svog nadvođa iznad površine vode. Pokus se može provesti pomoću utega ili ljudi ekvivalentne težine u slučaju da ih se tijekom pokusa ne dovodi u opasnost. Detaljan opis pokusa sa svim zahtjevima opisan je u *Pravilima* u ANNEX-u E.

#### 2.4. Proračun jedrilica prema normi HRN ISO 12217-2:2002

Ova norma namijenjena je procjeni plovnosti i stabiliteta plovila primarno pokretanih snagom vjetra, a duljine od 6 m do 24 m. Također, primjenjiva je i na brodove kraće od 6 m ukoliko zadovoljavaju osnovne zahtjeve ove norme. Suprotno tome, ova norma isključuje:

- plovila na napuhavanje duljine do 8 m (*ISO 6185*)
- kanue, kajake i ostale brodove širine manje od 1,1 m

Također, u obzir nisu uzete ni radnje poput vuče, ribarenja, kopanja dna, podizanja i sl., koje treba posebno ispitati ukoliko je potrebno.

Budući da su testovi i zahtjevi koji se tiču naplavljivosti, točnije zahtjev naplavljivih otvora, visine naplavljivanja te kuta naplavljivanja isti kao i kod motornih brodova, oni neće biti u nastavku ponovno opisivani. Pažnja će se obratiti na zahtjeve i pokuse karakteristične za proračun jedrilica. Budući da je način postizanja stabiliteta kod jednotrupaca i višetrupaca potpuno drugačiji, te da postoje razlike u odzivu broda na vanjske poremećaje u vidu uzdužnog i poprečnog stabiliteta, u ovom dijelu rada zasebno će se razmatrati ta dva oblika forme trupa. Svi navedeni pokusi, uz promijenjene zahtjevane vrijednosti, odnosno kriterije, primjenjivi su i na brodove ispod 6 m. Kod velikih brodova trgovačke mornarice ovi zahtjevi ne primjenjuju se zbog drugačijeg sustava pogona te dimenzija plovila. Tabela 4. prikazuje popis zahtjevanih testova i proračuna s obzirom na odabranu opciju, odnosno projektnu kategoriju i oblik trupa.

**Tabela 4. Raspodjela zahtjeva po projektnim kategorijama jedrilica**

OPCIJA	1	2	3	4	5	6	7	8
Moguća kategorija	A i B	C i D	B	C i D	C i D	C i D	C i D	A-D
Izvedba plaube	Neprekinuta	Neprekinuta	Svejedno	Svejedno	Djelomično neprekinuta	Svejedno	Svejedno	Svejedno
Downflooding openings	X	X	X	X	X	X	X	X
Downflooding height test	X	X	X		X			
Downflooding angle	X	X						
Angle of vanishing stability	X	X						
Stability index - STIX	X	X						
Knockdown-recovery test		X		X				
Wind stiffness test					X	X		
Flotation requirements				X		X		X
Capsize recovery test							X	

### 2.4.1. Angle of vanishing stability $\phi_{V(R)}$ (Kut gubitka stabilnosti)

Budući da zbog sile potlaka na zavjetrinskoj strani jedara, jedrilica tijekom plovidbe na jedra ima konstantan bočni nagib, potrebno je osigurati dovoljno stabilnosta da i u slučaju nepovoljnih vremenskih uvjeta jedrilica ne izgubi stabilnost. Kao i za većinu testova, ukoliko želimo zadovoljiti kriterije za projektne kategorije A i B, proračunu je potrebnu pristupiti u dva stanja krcanja, ovisno o već spomenutom odnosu masa. Osnovni zahtjevi za kut gubitka stabilnosti koje registar propisuje, ovisno o projektним kategorijama, dani su u nastavku (v. Tabela 5.)

**Tabela 5. Zahtjevani kut gubitka stabilnosti**

Projektna kategorija	Zahtjevani kut gubitka stabilnosti ( $\phi_{V(R)}$ )
A	$m > 3\,000\text{ kg}$ , $\phi_{V(R)} = (130 - 0,002m)$ ali uvijek $\geq 100^\circ$
B	$m > 1\,500\text{ kg}$ , $\phi_{V(R)} = (130 - 0,005m)$ ali uvijek $\geq 95^\circ$
C	$\phi_{V(R)} = 90^\circ$
D	$\phi_{V(R)} = 75^\circ$

### 2.4.2. Stability index - STIX (Indeks stabilnosti)

Određivanje indeksa stabilnosti (u nastavku STIX) sveobuhvatna je metoda procjene značajki stabiliteta jednotrupnih jedrilica. Temeljena je na modificiranju duljinskog faktora faktorima koji predstavljaju pojedine aspekte značajki stabiliteta i plovnosti te podacima iz krivulje momenta statičkog stabiliteta. Svaki od sedam faktora računa se za zahtjevano stanje krcanja prema izrazima koje propisuju *Pravila*. Svi faktori mogu se izračunati opsežnom metodom, približnom metodom, ili može biti uzeta minimalna zahtjevana vrijednost, kako propisuju *Pravila*. Svih sedam faktora s kratkim opisima navedeno je u tablici u nastavku (v. Tabela 6).

**Tabela 6. STIX utjecajni faktori** [*Principles of yacht design*]

Faktor	Opis
Dynamic stability (FDS)	Opisuje dinamički stabilitet jedrilice. Proporcionalan je radu ispod krivulje momenta statičke stabilnosti, odnosno energiji stabiliteta koja se odupire radu vanjskih sila vjetra.
Inversion recovery factor (FIR)	Sposobnost jedrilice da se samostalno vrati u uspravan ravnotežni položaj nakon polijeganja.
Knockdown recovery factor (FKR)	Karakterizira sposobnost pražnjenja vode iz jedara nakon polijeganja jedrilice, odnosno nakon što jedra urone pod vodu.
Displacement-length factor (FDL)	Odnos istisnine i veličine broda. Sa stanovišta upravljivosti, mala istisnina naspram velikih duljinskih dimenzija može biti veliki nedostatak.
Beam-displacement factor (FBD)	Odnos širine i istisnine. Velika širina u kombinaciji s malo istisninom povećava izgled prevrtanja uslijed valova. Također, mala vrijednost omjera širine i istisnine negativno utječe na stabilitet forme.
Wind moment factor (FWM)	Za trupove koji imaju kut naplavlivanja manji od 90° ovaj faktor predstavlja rizik naplavlivanja uslijed naleta vjetra za jedrilicu sa punom površinom jedara (nepokraćena jedra).
Downflooding factor (FDF)	Predstavlja rizik od naplavlivanja tijekom polijeganja broda.

Konačna vrijednost STIX-a računa se prema izrazu:

$$STIX = (7 + 2,25L_{BS})(FDS \times FIR \times FKR \times FDL \times FBD \times FWM \times FDF)^{0,5} + \delta \quad (2)$$

$$L_{BS} = (2L_{WL} + L_H)/3, [m]$$

$\delta$  – faktor definiran prema *Pravilima*

Najutjecajni faktori na konačni iznos STIX-a tiču se jedara i opute (FKR i FDS) te kuta naplavljivanja (FDF). Vrijednosti zahtjevane za pojedine kategorije dane su u tablici u nastavku.

**Tabela 7. Zahtjevane vrijednosti STIX-a**

Projektna kategorija	A	B	C	D
Minimalna vrijednost	32	23	14	5

### **2.4.3. Knock-down recovery test (Test polijeganja)**

Svrha testa je prikazati da jedrilica nakon polijeganja, odnosno nakon što jarbolom dotakne površinu vode, jedrilica ima sposobnost samostalno vratiti se u uspravni ravnotežni položaj. Test se može provesti eksperimentalno ili teoretski. Provodi se u uvjetima mirne vode, u stanjem krcanja lakog broda i ukrcanom posadom. Prilikom testa jedra moraju biti spuštена, a kobilica podignuta osim u slučaju ako može biti trajno fiksirana u najnižem položaju. Svi uvjeti moraju biti napomenuti u korisničkom priručniku broda. Kategorije A i B nisu podložne ovom proračunu, a kategorija C zahtjeva brzi povratak u uspravni položaj nakon nagiba kontinuiranog trajanja 60 s i posljedičnog naplavljivanja. Kategorija D zahtjeva povratak u ravnotežni položaj nakon 10 s nagiba od 90°.

Umjesto praktičnog dokaza, teoretski je također valjan, uz uvjet da brod ima pozitivan statički moment stabilizacije za spomenuti kut nagiba, te da je glavni ulaz u potpalublje otvoren i naplavljivanje omogućeno kroza nj.

#### 2.4.4. Wind stiffness test

Test mora dokazati da tijekom jedrenja uz stalni vjetar propisan za određenu kategoriju, uslijed nagiba broda izazvanog silom vjetra, neće doći do naplavlivanja.

Pokus se izvodi za stanje krcanja lakog broda s jednom osobom na komandnoj poziciji za kormilom. Jedra moraju biti spuštena, ali spremna za podizanje, a kobilica uvučena ili ako je moguće pričvršćena u najdonjoj poziciji. Prema uputama navedenim u pravilima potrebno je nariniti spreg sila koji će nagnuti brod do položaja kad nastupa prva od navedenih situacija:

- brod se počinja puniti vodom
- opterećenje momentom i nagib zadovoljavaju vrijednosti propisane kategorijom
- brod se nagnuo pod gutem od 45° (nakon toga slijedi smanjenje sile vjetra uslijed smanjenja projicirane površine jedara)

Rezultati testa moraju dati veličinu poluge sprega sila  $h$  [m], iznos sile  $T$  [kg] i kut nagiba  $\phi_T$  [°]. Iz navedenog računamo maksimalnu dozvoljenu brzinu vjetra prema formuli:

$$v_w = \sqrt{\frac{13hT + 390B_H}{A'_s h(\cos \Phi_T)^{\frac{1}{3}}}} \quad (3)$$

$A'_s$  – stvarni profil projicirane površine punog plana jedara

Alternativno, brzina vjetra može se odrediti iz dijagrama statičkog momenta stabiliteta i prekretnog momenta vjetra. Brodu se pridodaje projektna kategorija s obzirom na brzinu vjetra koja mora premašivati minimalne vrijednosti za pojedine kategorije navedene u Tabela 8.)

**Tabela 8. Zahtjevane brzine vjetra**

Projektna kategorija	C	D
Opcija 5	13	8
Opcija 6	11	6

Ukoliko jedrilica nije u mogućnosti zadovoljiti navedene kriterije sa podignutim punim jedrima, može joj se dodijeliti kategorija na temelju istog proračuna, ali za površinu pokraćenih jedara pod uvjetima:

- Površina pokraćenih jedara mora biti veća od 2/3 pune površine
- Snaga vjetra u [Bf] pri kojoj je potrebno provesti kraćenje jedara mora biti jasno navedena u korisničkom priručniku broda
- Znak upozorenja mora biti postavljen na glavnoj kontrolnoj poziciji

#### **2.4.5. Capsize-recovery test (Test izvrtnja)**

Testom izvrtnja želimo pokazati da prevrnuti broda može biti vraćen u uspravan ravnotežni položaj isključivo intervencijom posade te njihovom vlastitom težinom ili spravama ciljano projektiranim za tu svrhu i stalno dostupnim na brodu. Nakon uspravljanja brod mora ostati plutati. Sve poduzete mjere moraju biti izvedive s minimalnim brojem članova posade.

Pokus se provodi u mirnim vremenskim uvjetima, za brod u stanju kraccanja laganog broda s osnovnom opremom i uključenim svim uzgonskim pomagalima.

Glavno jedro i prednje jedro (flok ili genova) moraju biti podignuti i potrimani, a kobilica u spuštenoj poziciji.

Na početku eksperimenta, brod je potrebno izvrnuti za otprilike 180° ili najveći mogući ravnotežni kut, s posadom u vodi u okolini broda. Dubina mora biti dovoljna da se pokus može odvijati nesmetano. Brod ne smije potonuti ni nakon provedenih pet minuta u izvrnutom položaju. Posada mora biti u mogućnosti vratiti brod u uspravan položaj, bez ispušivanja vode ili pomoći sa strane, u najviše tri pokušaja od kojih svaki mora biti kraći od pet minuta.

#### **2.4.6. Breaking waves**

Za katamarane i trimarane potrebno je provesti navedeni test kojim osiguravamo razinu sigurnosti od izvrtnja od strane velikih valova. Faktor veličine višetrupca definiran je izrazom i ne smije premašiti dobivenu vrijednost:

$$MSF = 1,75 m_{MOC} \sqrt{L_H B_{CB}} \quad (5)$$

$m_{MOC}$  može se izračunati bilo vaganjem ili proračunom iz brodskih linija.



### 3. UPUTE KORISNIKU TABLIČNOG KALKULATORA

#### 3.1. Općenito

Tablični kalkulator u prilogu ovoga rada kodirani je zapis *ISO 12217:2002* norme. Tablice su koncipirane prema preporuci *Pravila* i ovisno o duljini i načinu propulzije podijeljene u tri datoteke. Unutar same datoteke tablice su podijeljene prema testovima i zahtjevima, na radne listove (*Worksheet* u datoteci označeni oznakom *No. X*), gdje *X* predstavlja redni broj lista. Svi listovi unutar pojedine datoteke povezane su poveznicama i automatski se računaju. Također, sve veličine se unose redom pojavljivanja u proračunu, a jednom unesenu veličinu kasnije je nemoguće promijeniti. Osim numeričkog unosa podatak, na nekim mjestima opcije se moraju izabrati iz padajućih izbornika. Klikom na ćeliju, bočno pored ćelije pojavljuje se ikona koja otvara pojedini padajući izbornik. Sve formule koje se koriste u proračunu vidljive su u traci za unos funkcije, a pored svake ćelije u tablici navedena je i referenca na *Pravila*. Osim ćelija namjenjenih unosu, ćelije sa formulama nemoguće je mijenjati.

### 3.2. Unos podataka

Unos podataka započinje se unosom informacija o projektu, željene kategorije, obliku trupa te unosom vrijednosti masa u tablicu masa na Radnom listu 1. U svim tablicama, ćelije namjenjene upisu ispunjene su sivom ispunom ( ćelija ). Ukoliko projekt zadovoljava uvjete za proračun prema korištenom dijelu *Pravila*, na dnu tablice pojavljuje se zelena oznaka koja upućuje na Radni list 2. na kojem odabiremo opciju plovila.

Tijekom odabira opcije bitno je obratiti pažnju na sukladnost izbora projektne kategorije i željene opcije. U slučaju dobrog odabira, polje sa odabranom opcijom poprimit će zelenu ispunu, a u slučaju neslaganja opcije sa kategorijom ćelija će pocrveniti. (v. Slika 4.)

SELECT OPTION:	1	SELECT OPTION:	3
OPTION SELECTED:	1	OPTION SELECTED:	ERROR

Slika 4. Pravilno i nepravilno odabrane opcije

Nakon pravilnog izbora opcije proračun se nastavlja na sljedećim Radnim listovima. Ukoliko je potrebno provesti određeni proračun to će biti jasno označeno u zaglavlju tablice, pored naslova:

ISO 12217-1 CALCULATION WORKSHEET No. 3		OFFSET-LOAD TEST				
<b>COMPLETE ALL THE TABLES BELOW</b>						
Is your boat SINGLE LEVEL or MULTI-LEVEL	SINGLE-LEVEL	Downflooding angle:	NOT NEEDED			
		Item	Symbol	Unit	Value	Ref
		Required value: (where $\theta_s$ = angle from offset load test)				6.1.1.1
		Category A = larger of $(\theta_s + 25)^\circ$ or $30^\circ$	$\theta_{(A)}$	degrees	30,00	Table 3
		Category B = larger of $(\theta_s + 15)^\circ$ or $25^\circ$	$\theta_{(B)}$	degrees	25,00	Table 3

Slika 5. Oznaka za proračun potrebne i nepotrebne tablice

Ukoliko rezultat proračuna zadovoljava uvjet odabrane kategorije, na dnu proračunske tablice to će biti označeno zelenom ispunom i tekсом „PASS“ ili kategorijom koju unesene veličine zadovoljavaju. Također, ćelije će biti ispunjene crvenom ispunom i oznakom „FAIL“.

ARE ALL CATEGORY REQUIREMENTS SATISFIES? PASS / FAIL	PASS	PASS	
Design Category given:	A		

Is angle of heel due to wind less than permitted value? YES / NO	NO	NO	
Design Category possible on wind heeling =	FAIL		

Slika 6. Zadovoljenje i nezadovoljenje proračunskih uvjeta

**Posebne napomene:**

U tablicama koje računaju visinu naplavlivanja na uzimajući u obzir samo duljinu plovila, u tablici se pojavljuje oznaka *N/A*, standardna oznaka za pogrešku tijekom proračuna u tabličnom kalkulatoru. Pogreška je uočena, no zbog tehničke naravi naredbe „LOOKUP“ nije mogla biti izbjegnuta. Međutim ona **NE UTJEČE** na rezultat jer vrijednosti koje su trebale biti navede u ćeliji nisu mjerodavne u određenu kategoriju, već služe samo kao orijentacijska vrijednost korisniku.

Downflooding Height:	COMPLETE THE TABLE BELOW			
Requirement	Basic requirement	Reduced value for small openings	Reduced value at outboard	Increased value at bow
applicable to	all options	all options but only if figures are used	options 3, 4	options 3, 4, 6
Ref.	6.1.2.2 a)	6.1.2.2 d)	6.1.2.2 c)	6.1.2.2 b)
obtained from Figs. 2+3 or annex A?	Figs. 2 + 3	= basic x 0,75	= basic x 0,80	= basic x 1,15
maximum area of small openings ( $50 L_H^2$ ) (mm <sup>2</sup> ) =		10224,50	//////////	//////////
Required Downflood Height $h_{DB}$ (m)	Fig. 2 / annex A Category A 0,850	0,638	NOT NEEDED	NOT NEEDED
	Fig. 2 / annex A Category B 0,842	0,632	NOT NEEDED	NOT NEEDED
	Fig. 2 / annex A Category C #N/A	#N/A	NOT NEEDED	NOT NEEDED
	Fig. 2 / annex A Category D #N/A	#N/A	NOT NEEDED	NOT NEEDED
Actual Downflooding Height $h_D$	0,850	0,638	5,000	5,000
Design Category possible	A	A	NOT NEEDED	NOT NEEDED
Design Category possible on Downflooding Height = lowest of above				A

Slika 7. Tehnički nedostatak

**3.3. Završna uputa**

Tablični kalkulatori namijenjeni su kao pomoć i informacija korisnicima koji započinju preliminarni projekt nekog plovila. Uz tablični kalkulator nužno je služiti se i *Pravilima* izdanima od strane nadležne institucije.

Iako je tablični kalkulator zaključan prema početnim postavkama, u slučaju da korisnik ima potrebu izmijeniti i prilagoditi proračun svojim potrebama, lozinka glasi : **ISO12217.**

#### 4. ZAKLJUČAK

Iako je teoretska podloga veoma slična, proračun stabiliteta i plovnosti malih brodova prema pravilima registra razlikuje se od proračuna za velike brodove. Prije svega, zbog relativno malih dimenzija metode proračuna često se mogu provesti kao praktični testovi. Također, u slučaju malih brodova, mala promjena pozicije težišta tereta (pomicanje ljudi, pražnjenje tankova) na brod ima znatan utjecaj, što kod velikih brodova nije slučaj.

Iako su *Pravila* često ugrađena u većinu komercijalnih programskih paketa, tablični kalkulator iz Priloga koristan je alat, naročito projektantu u preliminarnom stadiju proračuna. Kalkulator omogućuje uvid i u zahtjeve ostalih projektnih kategorija za pojedinu točku proračuna, što projektantu omogućava uvid u njegovu trenutnu poziciju u projektnom prostoru.

## LITERATURA

- [1] URŠIĆ, J.: "Stabilitet broda", Sveučilište u Zagrebu, Zagreb, 1962.
- [2] INTERNATIONAL MARITIME ORGANISATION: „International code on intact stability, 2008“, 2008.
- [3] HRN EN ISO 12217-1:2002, „Mala plovila – Ocjena i razredba stabiliteta i plovnosti – 1. Dio: Mala plovila bez jedara duljine trupa 6 m ili više“; Fakultet strojarstva i brodogradnje, Zagreb, 2003.
- [4] LARSSON, L.; ELIASSON, R. E.: "Principles of yacht design", Adlard Coles Nautical, London, 2000.
- [5] HRN EN ISO 12217-2:2002, „Mala plovila – Ocjena i razredba stabiliteta i plovnosti – 2. Dio: Jedrilice duljine trupa 6 m ili više“; Fakultet strojarstva i brodogradnje, Zagreb, 2003.
- [6] HRN EN ISO 12217-3:2002, „Mala plovila – Ocjena i razredba stabiliteta i plovnosti – 3. Dio: Brodice duljine trupa manje od 6 m“; Fakultet strojarstva i brodogradnje, Zagreb, 2003.

## **PRILOZI**

- I. Tablični kalkulator ISO 12217-1 s uključenim proračunom M/B „Baldo Kosić II“
- II. Tablični kalkulator ISO 12217-2 s uključenim proračunom jedrilice „YD-40“
- III. Tablični kalkulator ISO 12217-3
- IV. CD-R disc

# **PRILOG 1.**

Tablični kalkulator

**ISO 12217-1**

s uključenim proračunom

**M/B „Baldo Kosić II“**

NOT NEEDED		m/b BALDO KOSIĆ II			
Design Category intended:	A	monohull / multihull:	MONOHULL		
Item	Symbol	Units	Value	Ref.	
Length of hull (as in ISO 8666)	$L_H$	m	14,30		
Beam of hull (as in ISO 8666)	$B_H$	m	5,00		
Length on waterline (as ISO 8666)	$L_{WL}$	m	14,00		
Length on waterline (as ISO 8666)	$B_{WL}$	m	5,00		
<b>Mass:</b>					
<b>Maximum total load:</b>					
Desired Crew Limit	$C_L$	persons	5	3.4.2	
Mass of:					
desired Crew Limit at 75 kg each		kg	375,00		
provisions + personal effects		kg	250,00		
fresh water		kg	4190,00		
fuel		kg	3354,00		
other consumable carried aboard		kg	750,00		
stores, spare gear and cargo (if any)		kg	1200,00		
optional equipment and fittings not included in basic outfit		kg			
inflatable liferaft		kg			
other small craft carried aboard		kg			
margin for future additions		kg			
<b>Maximum total load = sum of above weights</b>	$m_{MTL}$	kg	<b>10119,00</b>	3.4.2	
<b>Light craft condition mass</b>	$m_{LCC}$	kg	<b>48425,00</b>	3.4.1	
<b>Loaded displacement mass = <math>m_{LCC} + m_{MTL}</math></b>	$M_{LDC}$	kg	<b>58544,00</b>	3.4.4	
Mass of:					
minimum number of crew		kg	150,00	3.4.6	
essential safety requirements [not less than $(L_H - 2,5)^2$ ]		kg	139,24	3.4.6	
non-consumable stores and equipment normally aboard		kg	500,00	3.4.6	
water ballast in tanks which are notified in the owner's manual to be filled whenever the boat is afloat		kg	0,00	3.4.6	
inflatable liferaft		kg	0,00	3.4.6	
Load to be included in Minimum Loading Condition	$m_L$	kg	789,24	3.4.6	
<b>Light Craft Condition mass</b>	$m_{LCC}$	kg	48425,00	3.4.1	
Mass in the Minimum Operating Condition = $m_{LCC} + m_L$	$m_{MOC}$	kg	49214,24	3.4.7	
<b>Is boat sail or non-sail?</b>					
nominal sail area	$A_S$	m <sup>2</sup>	0,00	3.1.2	
sail area / displacement ratio = $A_S / (m_{LDC})^{2/3}$			-	0	3.1.2
CLASSIFIED AS (non-sail if $A_S / (m_{LDC})^{2/3} < 0,07$ ) SAIL / NON-SAIL ?			NON-SAIL	3.1.2	

CONTINUE USING THIS FILE - GO TO WS No. 2



COMPLETE THE TABLE BELOW

Question	Answer	Ref.
Is boat fully decked? (see definition in ref.) YES / NO?	YES	3.1.6
Is boat partially decked? (see definition in ref.) YES / NO?	YES	3.1.7
Ratio of $m_{LDC} / m_{MOC}$ (using data from worksheet 1)	1,190	
If ratio > 1,15 then subclause 6.3 is required to be assessed at both $m_{MOC}$ and $m_{LDC}$	ASSESS BOTH mMOC & mLDC	6.3.1

Item	Symbol	Units	Value	Ref.
Windage area	$A_{LV}$	m <sup>2</sup>	37,10	3.3.7
Length of Hull	$L_H$	m	14,30	3.3.1
Beam of Hull	$B_H$	m	5,00	3.3.3
Ratio $A_{LV} / (L_H B_H)$		-	0,52	

Choose any ONE of the following options, and use the worksheets indicated for that option.

option	1	2	3	4	5	6
Categories possible	A and B	C and D	B	C and D	C and D	C and D
Decking or covering	fully decked	fully decked	any amount	any amount	partially decked	any amount
Offset load test	3	3	3	3	3	3
Downflooding openings	4	4	4	4	4	4
Downflooding angle	4 <sup>a</sup>	4 <sup>a</sup>	4 <sup>a</sup>	4 <sup>a, b</sup>		
Downflooding height test	all boats	4	4	4	4 <sup>b</sup>	4
	full method	5	5	5	5 <sup>b</sup>	5
Resistance to waves + wind	6a + 6b <sup>a</sup>		6a + 6b <sup>a</sup>			
Heel due to wind action		7 <sup>a, c</sup>		7 <sup>a, c</sup>	7 <sup>a, c</sup>	7 <sup>a, c</sup>
Flotation test			8	8		
Flotation material			8	8		
SUMMARY	9	9	9	9	9	9

a If the ratio  $m_{LDC} / m_{MOC} > 1,15$ , this requirement must be completed and satisfied for BOTH Minimum Operating Condition AND Loaded Displacement Condition.

b This test is not required for boats assessed using option 4 if, during the swamped load test in Worksheet 8, the boat has been shown to support an equivalent dry mass of one third more than maximum total load.

c The application of Worksheet 7 is only required for boats where  $A_{LV} / (L_H * B_H) \geq 1,0$

SELECT OPTION:

1

OPTION SELECTED:

1

## COMPLETE THE TABLE BELOW

Is your boat SINGLE LEVEL or MULTI-LEVEL

MULTI-LEVEL

Calculation of heeling moment for boats with not more than one level:

Item	Symbol	Unit	Value	Ref.
Plan area for movement of crew	$A_c$	m <sup>2</sup>	60	B.3.1 a)
Crew density = $CL/4A_c$	CD	m <sup>-2</sup>	0,02	B.3.1 a)
Maximum breadth of Crew area	$B_c$	m	5	B.3.1 b)
Crew heeling moment	— if $CD \geq 0,5 = 314 * A_c * B_c$ — if $CD < 0,5 = 314 * CL * B_c * (1 - CD)$	$M_c$	Nm	NOT NEEDED B.3.1 b)

Calculation of heeling moment for boats with more than one level:

	Crew area	Number of crew	Crew density	Crew area maximum breadth	Crew heeling moment	Ref.
symbol :	$A_c$	N	CD	$B_c$	$M_c$	
units :	m <sup>2</sup>	—	m <sup>-2</sup>	m	Nm	
level		$\leq 2A_c$	$= N/4A_c$ $\leq 0,5$		calculation as in table above	Annex B
highest level	15	2	0,03	4,50	6829,50	B.3.2 a) + b)
next highest level	45	2	0,01	5,00	7762,78	B.3.2 c) + d)
next highest level	5	1	0,05	4,00	5966,00	B.3.2 e) + f)
next highest level	0		0,00		0,00	B.3.2 g)
total of values of $N = CL =$		5	total values of $M_c =$		20558,28	B.3.2 g) + h)

## Compliance with requirement:

Item	Symbol	Unit	Value	Ref.
Equivalent moment in kg*m for test = $M_c/9,806$		kg-m	2096,50	
Angle of heel with $M_c$ applied (acc. ANEX B)	$\phi_o$	degrees	4,00	6.2
Max. angle of heel allowed = $10 + \frac{(24 - L_H)^3}{600}$	$\phi_{o(R)}$	degrees	11,52	6.2
PASS/FAIL?			PASS	

## In addition, for boats using options 5 and 6:

Requirement:	Cat. C > 0,11* $V_{LH}$	Cat. D > 0,07* $V_{LH}$	Value	Ref.
least height to waterline (m)	0,42	0,26	0,45	6.2 a) + b)
Design category given:			NOT NEEDED	

ISO 12217-1 CALCULATION WORKSHEET No. 4		DOWNFLOODING	
NOT NEEDED		COMPLETE THE TABLE BELOW	
Question		Answer	Ref.
Have all appropriate downflooding openings been identified? YES / NO		YES	6.1.1.1
Do all closing appliances satisfy ISO 12216? YES / NO		YES	6.1.1.2
Opening type appliances are not fitted below 0,2 m above waterline unless they comply with ISO 9093 or ISO 9094? YES / NO		YES	6.1.1.3
Are all openings fitted with closing appliances (except openings for ventilation and engine combustion)? YES / NO		YES	6.1.1.5
Categories possible: A or B if all are YES, C or D if first two are YES		A or B	6.1.1

Downflooding angle:		COMPLETE FOR BOTH MOC & LDC			
Item	Symbol	Unit	Value	Ref	
Required value: (where $\phi_0$ = angle from offset load test)					
Category A = larger of $(\phi_0 + 25)^\circ$ or $30^\circ$	$\phi_{D(R)}$	degrees	30,00	Table 3	
Category B = larger of $(\phi_0 + 15)^\circ$ or $25^\circ$	$\phi_{D(R)}$	degrees	25,00	Table 3	
Category C = larger of $(\phi_0 + 5)^\circ$ or $20^\circ$	$\phi_{D(R)}$	degrees	20,00	Table 3	
Category D = $\phi_0$	$\phi_{D(R)}$	degrees	4,00	Table 3	
Areas of openings permitted to be submerged = $50 L_H^2$		mm <sup>2</sup>	10225	6.1.3	
Actual downflooding Angle: at mass = $m_{MOC}$	$\phi_D$	degrees	45,4	6.1.3	
If ration of $m_{LDC}/m_{MOC} > 1,15$ then at mass = $m_{LDC}$	$\phi_D$	degrees	40,9	6.1.3	
$m_{LDC}/m_{MOC} =$	1,19	Method used to determine $\phi_D$ :		Annex C	
			THEOR.		
Design Category possible on Downflooding Angle			A	6.3	

Downflooding Height:		COMPLETE THE TABLE BELOW			
Requirement	Basic requirement	Reduced value for small openings	Reduced value at outboard	Increased value at bow	
applicable to	all options	all options but only if figures are used	options 3, 4	options 3, 4, 6	
Ref.	6.1.2.2 a)	6.1.2.2 d)	6.1.2.2 c)	6.1.2.2 b)	
obtained from Figs. 2+3 or annex A?	Figs. 2 + 3	= basic x 0,75	= basic x 0,80	= basic x 1,15	
maximum area of small openings ( $50 L_H^2$ ) (mm <sup>2</sup> ) =		10224,50	//////////	//////////	
Required Downflood Height $h_{D(R)}$ (m)	Fig. 2 / annx. A Category A	0,850	0,638	NOT NEEDED	NOT NEEDED
	Fig. 2 / annx. A Category B	0,842	0,632	NOT NEEDED	NOT NEEDED
	Fig. 2 / annx. A Category C	#N/A	#N/A	NOT NEEDED	NOT NEEDED
	Fig. 2 / annx. A Category D	#N/A	#N/A	NOT NEEDED	NOT NEEDED
Actual Downflooding Height $h_D$		1,131	0,638	5,000	5,000
Design Category possible		A	A	NOT NEEDED	NOT NEEDED
Design Category possible on Downflooding Height = lowest of above				A	

NOT NEEDED

Calculation using annex A assuming use of option .....

Item	Symbol	Unit	Opening 1	Opening 2	Opening 3	Opening 4	
<b>Position of openings:</b>							
Least longitudinal distance from bow/stern	x	m					
Least transverse distance from gunwale	y	m					
$F_1 = \text{greater of } (1 - x/L_H) \text{ or } (1 - y/B_H) =$	$F_1$	—	1,00	1,00	1,00	1,00	
<b>Size of openings:</b>							
Combined area of openings to top of any down-flooding opening	a	mm <sup>2</sup>					
Longitudinal distance of opening from tip of bow	$x'_D$	m					
Limiting value of $a = (30L_H)^2$		mm <sup>2</sup>	184041	184041	184041	184041	
If $a \geq (30L_H)^2$ , $F_2 = 1,0$ If $a < (30L_H)^2$ , $F_2 = 1 + \frac{x'_D}{L_H} \left( \frac{\sqrt{a}}{75L_H} - 0,4 \right)$	$F_2$	-	1,000	1,000	1	1	
<b>Size of recesses:</b>							
Volume of Recesses which are not quick-draining in accordance with ISO 11812	$V_R$	m <sup>3</sup>					
Freeboard amidships (see 3.3.5)	$F_M$	m					
$k = V_R / (L_H B_H F_M)$	k	—	#DIV/0!	#DIV/0!	#DIV/0!	#DIV/0!	
If opening is not a recess, $F_3 = 1,0$ If recess is quick-draining, $F_3 = 0,7$ If recess is not quickdraining $F_3 = (0.7 + k^{0.5})$	$F_3$	—					
$F_3 =$			ERROR	ERROR	ERROR	ERROR	
<b>Displacement:</b>							
Loaded displacement volume (see 3.4.5)	$V_D$	m <sup>3</sup>		57,12			
$B = B_H$ for monohulls, $B_{WL}$ for multihulls	B	m		5,00			
$F_4 = [(10 V_D)/(L_H \times B^2)]^{1/3}$	$F_4$	—		1,17			
<b>Flotation:</b>							
For boats using options 3 or 4, $F_5 = 0,8$ For all other boats, $F_5 = 1,0$	$F_5$	—		1,00			
<b>Required Calc. Height:</b> $= F_1 F_2 F_3 F_4 F_5 L_H / 15$	$h_{D(R)}$	m	#VALUE!	#VALUE!	#VALUE!	#VALUE!	
Required Downflooding Height with Limits applied (see Annex A, Table A.1)	Category A	$h_{D(R)}$	m	#VALUE!	#VALUE!	#VALUE!	#VALUE!
	Category B	$h_{D(R)}$	m	#VALUE!	#VALUE!	#VALUE!	#VALUE!
	Category C	$h_{D(R)}$	m	FALSE	FALSE	FALSE	FALSE
	Category D	$h_{D(R)}$	m	FALSE	FALSE	FALSE	FALSE
<b>Measured Downflooding Height:</b> (input on worksheet No.4)	$h_D$	m					
<b>Design Category possible:</b>			#VALUE!	#VALUE!	#VALUE!	#VALUE!	
<b>GIVEN CATEGORY</b> (lowest of above) =			#VALUE!	#VALUE!	#VALUE!	#VALUE!	

NOT NEEDED		COMPLETE BOTH FOR MOC & LDC			
Item	Symbol	Units	Cat A ( $m_{MOC}$ )	Cat B ( $m_{LDC}$ )	Ref.
Mass in minimum operating condition	$m_{MOC}$	kg	49214,24		3.4.7
Loaded displacement mass	$m_{LDC}$	kg	58544,00		3.4.4
Is ratio of $m_{LDC} / m_{MOC} > 1,15$ ?	YES/NO		YES		6.1.3
<b>NB: If YES, sheets 6a and 6b must be completed for both loading conditions</b>					6.3.1
Displacement volume (= $m_{MOC}$ or $m_{LDC}/1025$ )	$V_D$	$m^3$	48,01	57,12	3.4.5
Plan area of all recesses	$A_R$	$m^2$	0,00		6.3.1
Plan area of all recesses forward of $L_H/2$	$A_{RF}$	$m^2$	0,00		6.3.1
Windage area (of above water profile of boat)	$A_{LV}$	$m^2$	37,10	37,10	3.3.7
Windage area to be used (not to be $< 0,55 L_H * B_H$ )	$A'_{LV}$	$m^2$	39,33	39,33	6.3.2
Length waterline	$L_{WL}$	m	11,25	11,25	3.3.2
Draught at the midpoint of $L_{WL}$	$T_M$	m	1,60	1,90	6.3.2
Downflooding angle	$\phi_D$	degrees	45,40	40,90	3.2.2
Calculation wind speed	$v_W$	m/s	28,00	21,00	3.5.1
<b>Recess limitations:</b>					
Item	Symbol		Cat A ( $m_{MOC}$ )	Cat B ( $m_{LDC}$ )	Ref.
Ratio of recess area to (length x beam)	$A_R / (L_H * B_H)$		0	0	6.3.1
Design category possible (A if $< 0,2$ ; B if $< 0,3$ )			YES	YES	6.3.1
Ratio of forward recess area to (length x beam)	$A_{RF} / (L_H * B_H)$		0	0	6.3.1
Design category possible (A if $< 0,1$ ; B if $< 0,15$ )			YES	YES	6.3.1

**COMPLETE BOTH FOR MOC & LDC**

Derived from the righting moment curve (see annex D):

**Rolling in beam waves and wind:**

Item	Symbol	Units	Cat.A (m <sub>MOC</sub> )	Cat.B (m <sub>LDC</sub> )	Ref.
Angle of vanishing stability	$\phi_V$	degrees	65,00	65,00	3.3.8
Least value of $\phi_D, \phi_V$ , or $50^\circ$	$\phi_{A2}$	degrees	45,40	40,90	
Wind heeling moment = $0,34 \cdot (A'_{LV}/L_{WL} + T_M) \cdot V_W^2$	$M_W$	Nm	47130,02	28071,44	6.3.2
Assumed roll angle Category A = $(25 + 20/V_D)$ Category B = $(20 + 20/V_D)$	$\phi_R$	degrees	25,42	25,35	6.3.2
Area $A_1$ (see figure 5, p16)	$A_1$	any	0,06	0,06	6.3.2
Area $A_2$ (see figure 5, p16)	$A_2$	any	0,10	0,09	6.3.2
Ratio of $A_2 / A_1$		—	1,71	1,62	6.3.2
Is ratio of $A_2 / A_1$ greater than or equal to 1,0 ?	YES / NO		YES	YES	6.3.2

**Resistance to waves:**

Item	Symbol	Units	Cat.A (m <sub>MOC</sub> )	Cat.B (m <sub>LDC</sub> )	Ref.
Least value of $\phi_D, \phi_V$ , or $50^\circ$	$\phi_{A2}$	degrees	45,4		
Heel angle when righting moment is maximum	$\phi_{GZmax}$	degrees	31		
<b>If <math>\phi_{GZmax}</math> is greater than or equal to <math>30^\circ</math>:</b> Max. value of righting moment at $30^\circ$ to $\phi_{A2}$	$RM_{max}$	Nm	145000		
Required min. value of righting moment (25000 Nm for cat. A, 7000 Nm for cat. B)		Nm	25000	7000	6.3.3 a)
Is $RM_{max}$ greater than or equal to required max. value?	YES / NO		YES	YES	6.3.3.b)
Max. value of righting lever = $RM_{max} / (9,806 m_{LDC})$	$GZ_{max}$	m	0,253		3.5.9
Required max value of righting lever		m	0,200		6.3.3 a)
Is $GZ_{max}$ greater than or equal to required max value?	YES / NO		YES		6.3.3 a)
<b>If <math>\phi_{GZmax}</math> is less than <math>30^\circ</math>:</b> Max. value of righting moment	$RM_{max}$	Nm			6.3.3.b)
Required max value of $RM_{max}$ (cat. A = $750/\phi_{GZmax}$ ; B = $210/\phi_{GZmax}$ )		Nm	24194	6775	6.3.3 b)
Is $RM_{max}$ greater than or equal to required max. value?	YES / NO		NOT NEEDED	NOT NEEDED	6.3.3.b)
Max. value of righting lever = $RM_{max} / (9,806 m_{LDC})$	$GZ_{max}$	m	0	0,000	3.5.9
Required max value of righting lever = $6/\phi_{GZmax}$		m	0,194		6.3.3 b)
Is $GZ_{max}$ greater than or equal to required max value?	YES / NO		NOT NEEDED	NOT NEEDED	6.3.3 b)
ARE ALL CATEGORY REQUIREMENTS SATISFIES? PASS / FAIL			PASS	PASS	
<b>Design Category given:</b>			<b>A</b>		

NB: Boat must meet both recess limitations, have ratio of  $A_2/A_1$  greater than or equal to 1,0, and also get YES twice under resistance to waves.

NOT NEEDED

NOT NEEDED

## Initial check:

Item	Symbol	Units	Value	Ref.
Is ratio of $m_{LDC} / m_{MOC} > 1,15$ ?			YES	6.1.3
<b>NB: If YES, this sheet must be completed for both loading conditions</b>				6.4
Windage area (of above water profile of boat)	$A_{LV}$	m <sup>2</sup>	37,10	3.3.7
Length of hull	$L_H$	m	14,30	3.3.1
Beam of hull	$B_H$	m	5,00	3.3.3
Ratio $A_{LV} / (L_H B_H)$		—	0,52	
Is ratio $A_{LV} / (L_H B_H)$ equal to or greater than 1,0 ?	YES / NO		NO	6.4

If answer is NO, no further assessment is required.

## Calculation of wind heeling moment:

Item	Symbol	Units	Cat. C( $m_{MOC}$ )	Cat. D( $m_{LDC}$ )	Ref.
Length waterline	$L_{WL}$	m	11,25		3.3.2
Draught at the midpoint of $L_{WL}$	$T_M$	m	1,60	1,90	6.3.2
Calculation wind speed (Cat C = 17, Cat D = 13)	$v_W$	m/s	17	13	3.5.1
Wind heeling moment = $0,3A_{LV}(A_{LV}/L_{WL} + T_M) v_W^2$	$M_W$	Nm	15754,05	9776,86	6.3.2

## Angle of heel due to wind:

Item	Symbol	Units	Cat. C( $m_{MOC}$ )	Cat. D( $m_{LDC}$ )	Ref.
FROM RIGHTING MOMENT CURVE: angle of heel due to wind	$\phi_W$	degrees			6.4
OR ALTERNATIVELY: offset load moment due to crew (see W'sheet 3)	$M_C$	Nm	20558,28	20558,28	Annex B
Heel angle during offset load test (see W'sheet 3)	$\phi_O$	degrees	4,00	4,00	6.2
Angle of heel due to wind = $(M_W / M_C) \phi_O$	$\phi_W$	degrees	3,07	1,90	6.4
Maximum permitted angle of heel during offset load test (from Worksheet 3)	$\phi_{O(R)}$	degrees	11,52		6.2
Maximum permitted angle of heel due to wind = $\phi_{O(R)} / 2$		degrees	5,76		6.4
Is angle of heel due to wind less than permitted value? YES / NO			YES	YES	
Design Category possible on wind heeling =			C		

**NOT NEEDED**

Annexes E and F

assumed Crew Limit (CL) =

5

**Preparation:**

Item	Units	Response	Ref.
Mass equal to 25% of dry stores and equipment added? YES / NO		YES	E.2 a)
Inboard or outboard engine fitted?		INBOARD	
If inboard fitted, correct engine replacement mass fitted? YES / NO		YES	E.2 d)
Assumed outboard engine power	kW		E.2 c)
Mass fitted to represent outboard engine, controls and battery	kg		Tables E.1+E.2
Portable fuel tanks removed and/or fixed tanks filled? YES / NO		YES	E.2 f)
Cockpit drains open and drain plugs fitted? YES / NO		YES	E.2 g)
Void compartments which are not air tanks opened? YES / NO		YES	E.2 i)
Number of integral air tanks required to be opened			Table E.3
Type of test weights used: lead, 65/35 brass, steel, cast iron, aluminium		65/35 BRASS	
Material factor <i>d</i>		1,138	Table E.4

**Swamped stability test:**

Item	Units	Response	Ref.
Dry mass of test weights = $(6 \cdot d \cdot CL)$ but $\geq (15 d)$	kg	34,14	Table E.6
Test weight hung from gunwale each of four positions in turn? YES / NO		YES	E.3.1
5 min. after swamping, does boat heel more than 45°? PASS / FAIL		PASS	E.3.4 + E.3.5

**Swamped buoyancy tests:**

Item	Units	Response	Ref.
<b>Load test:</b>			E.4
Mass of maximum total load $m_{MTL}$	kg	10119,00	3.4.2 + sheet 1
Design category assessed		A	
Dry mass of test weights (not less than)	kg	NOT NEEDED	Table E.5
5 min after swamping, does boat float approximately level with more than 2/3 of periphery above water? PASS / FAIL		PASS	E.4.3

**Flotation material and elements:**

Item	Response	Ref.
Do all flotation elements comply with all the requirements? PASS / FAIL	PASS	Table F.1

Design Category given: (NB: boat must obtain PASS three times in above tables)

**NOT NEEDED**



## COMPLETE THE TABLE BELOW

## Design Description:

Design Category intended:	<b>A</b>		Crew Limit:	<b>5</b>	Date:	18.9.2014
Sheet	Item	Symbol	Units	Value		
1	Length of hull: (as ISO 8666)	$L_H$	m	14,30		
	<b>Mass:</b>					
	Maximum total load	$m_{MTL}$	kg	10119,00		
	Light craft condition mass	$m_{LCC}$	kg	48425,00		
	Loaded displacement mass = $m_{LCC} + m_{MTL}$	$m_{LDC}$	kg	58544,00		
	Is ratio of $m_{LDC} / m_{MOC} > 1,15$ ?	YES/NO		YES		
Is boat sail or non-sail?	SAIL / NON-SAIL		<u>NON-SAIL</u>			
2	Option selected:	<b>1</b>				
3	<b>Offset load test:</b>	Units	Required	Actual	Pass/Fail	
	Testing for least stability: max. heel angle angle of heel with moment applied	degrees	< 11,52	4,00	PASS	
4	Testing for least freeboard: heeled freeboard margin option 5 and 6 boats: least height to waterline	mm	> NOT NEEDED	0,45	PASS	
	<b>Downflooding openings:</b>	Are all requirements met?			PASS	
4	Downflooding angle: at $m_{MOC}$	degrees	> 30	45,4	PASS	
	if $m_{LDC} / m_{MOC} > 1,15$ : at $m_{LDC}$	degrees	> 30	40,9	PASS	
4 or 5	<b>Downflooding height:</b>	Worksheet employed for basic height				
	Basic requirement	m	$\geq$ 0,850	1,131	PASS	
	Reduced height for small openings (sheet 4 only)	m	$\geq$ 0,638	0,638	PASS	
	Reduced height at outboard (options 3+4 only)	m	$\geq$ NOT NEEDED	5,000	PASS	
6 a	Increased height at bow (options 3, 4, 6 only)	m	$\geq$ NOT NEEDED	5,000	PASS	
	<b>Resistance to waves+wind:</b> (options 1, 3) : at $m_{MOC}$ and if $m_{LDC}/m_{MOC} > 1,15$ : must also comply at $m_{LDC}$					
	Limitation on total recess area	$m^2$	< 0,2	0,000	PASS	
	Limitation on total recess area forward of $L_H/2$	$m^2$	< 0,1	0,000	PASS	
6 b	Rolling in beam waves and wind: ratio $A_2/A_1$	---	$\geq$ 1	1,707	PASS	
	Resistance to waves: value of $\phi_{GZmax}$	degrees	---	31	-----	
	value of $RM_{MAX}$	Nm	> 25000	145000	PASS	
7	value of $GZ_{MAX}$	m	$\geq$ 0,2	0,253	PASS	
	Heel due to wind: (options 2,4,5,6) is ratio $A_{LV} / (L_H B_H) \leq 1,0$ ?				NO	
	at $m_{MOC}$ : heel angle due to wind	degrees	< 5,76	3,07	PASS	
8	if required at $m_{LDC}$ : heel angle due to wind	degrees	< 5,76	1,90	PASS	
	<b>Flotation test:</b> (options 3 and 4 only) All preparations completed? YES / NO				NOT NEEDED	PASS
	<b>Swamped stability:</b> 5 min after swamping, does boat heel less than 45°?				YES	PASS
	<b>Load test:</b> 5 min after swamping, does boat float level with 2/3 showing?				YES	PASS
<b>Flotation elements:</b> Do all elements comply with all the requirements?				YES	PASS	
NB: Boat must pass all requirements applicable to option to be given intended Design Category.						
Design Category given:					<b>A</b>	

# **PRILOG 2.**

Tablični kalkulator

**ISO 12217-2**

s uključenim proračunom

**jedrilice „YD-40“**

ISO 12217-2 CALCULATION WORKSHEET No. 1		GENERAL INFORMATION		
Design:		YD - 40		
Design Category intended:		A	Monohull/multihull:	MONOHULL
Item	Symbol	Unit	Value	Ref.
Length of hull (as in ISO 8666)	$L_H$	m	12,05	3.4.1
Beam of hull (as in ISO 8666)	$B_H$	m	3,71	
Length waterline (as ISO 8666)	$L_{WL}$	m	9,96	
Beam waterline (as ISO 8666)	$B_{WL}$	m	3,15	
<b>Mass:</b>				
<b>Maximum total load:</b>				
Desired Crew Limit	CL	-	8	3.5.4 3.6.3
<b>Mass of:-</b>				
desired Crew Limit at 75 kg each		kg	600,00	
provisions + personal effects		kg	320	
fresh water		kg	350	
fuel		kg	100	
other liquids carried aboard		kg		
stores, spare gear and cargo (if any)		kg	285	
optional equipment and fittings not included in basic outfit		kg		
inflatable liferaft		kg	39	
other small boats carried aboard		kg		
margin for future additions		kg	356,00	
<b>Maximum total load = sum of above masses</b>	$m_{MTL}$	kg	2050,00	3.5.4
<b>Light craft condition mass</b>	$m_{LCC}$	kg	7250,00	3.5.1
<b>Loaded displacement mass = <math>m_{LCC} + m_{MTL}</math></b>	$m_{LDC}$	kg	9300,00	3.5.6
<b>Mass of:</b>				
minimum number of crew according to 3.5.2		kg	150	3.5.2
essential safety equipment [not less than $(L_H - 2,5)^2$ ]		kg	356,00	3.5.2
non-consumable stores and equipment normally aboard		kg		3.5.2
water ballast in tanks which are notified in the owner's manual to be filled whenever the boat is afloat		kg		3.5.2
inflatable liferaft		kg	39,00	3.5.2
<b>Load to be included in Minimum Operating Condition</b>	$m_L$	kg	545,00	3.5.2
<b>Light craft condition mass</b>	$m_{LCC}$	kg	7250,00	3.5.1
<b>Mass in the Minimum Operating Condition = <math>m_{LCC} + m_L</math></b>	$m_{MOC}$	kg	7795,00	3.5.3
<b>Is boat sail or non-sail?</b>			SAIL	3.1.2
nominal sail area	$A_S$	$m^2$	71,80	3.4.8
sail area / displacement ratio = $A_S / (m_{LDC})^{2/3}$			0,16	3.1.2
CLASSIFIED AS [non-sail if $A_S / (m_{LDC})^{2/3} < 0,07$ ] SAIL/NON-SAIL?			SAIL	3.1.2
NB: If SAIL, continue using these worksheets, If NON-SAIL, use ISO 12217-1		<b>CONTINUE WITH ISO 12217-2</b>		

ISO 12217-2 CALCULATION WORKSHEET No. 2

TESTS TO BE APPLIED

COMPLETE THE TABLES BELOW

Question	Answer	Ref.
Is boat fully decked? (see definition in ref.) YES/NO?	YES	3.1.8
Is boat a catamaran or trimaran? YES/NO?	NO	3.1.3 and 3.1.4
<b>If NO, choose from options 1 to 7. If YES, then:</b>		<b>IGNORE REST OF TABLE. CHOOSE OPT 1-7</b>
Length of hull	$L_H$ m	12,05 3.4.1
Beam of hull	$B_H$ m	3,71
Beam between centres of buoyancy of sidehulls	$B_{CB}$ m	8 3.4.5
Is ratio $L_H / B_{CB} > 5$ YES / NO?	NOT NEEDED	7.1
<b>If YES, treat the boat as a monohull, and choose from options 1 to 7. If NO, use option 8</b>		<b>MULTIHULL - CHOSE OPT 8</b>
Mass in the minimum operating condition	$m_{MOC}$ kg	7795,00 3.5.3
Mass in the loaded displacement condition	$m_{LDC}$ kg	9300,00 3.5.6
Is $m_{LDC}/m_{MOC} > 1,15$ ?	$m_{LDC} / m_{MOC} =$	1,19 YES
<b>NB: If YES ( <math>m_{LDC}/m_{MOC} &gt; 1,15</math> ); then all worksheets marked * below must be completed for both conditions!!</b>		

Choose any ONE of the following options, and use the worksheets indicated for that option.

Option	All boats except catamarans and trimarans with $L_H / B_{CB} \leq 5$							Cats./tris.
	1	2	3	4	5	6	7	8
categories possible	A+B	C+D	C+D	C+D	C+D	C+D	C+D	A - D
decking or covering	fully decked	any amount	any amount	any amount	any amount	any amount	any amount	any amount
downflooding openings	3	3	3	3	3	3		3
downflooding angle	3*	3*						
downflooding height test	all boats	3	3		3			
	full method	4	4	4	4			
stability index	5*	5*						
angle of vanishing stability	6*	6*						
knockdown-recovery test			7	7				
wind stiffness test					8	8		
flotation requirement						9		
capsize recovery test							10	
multihull size factor								11
multihull size factor								12
Summary	13*	13*	13	13	13	13	13	13

SELECT OPTION: 1

Option selected 1

Recess limitations (option 1 only):	COMPLETE THE TABLE BELOW			
Item	Symbol	Unit	Value	Ref.
Plan area of all recesses	$A_R$	m <sup>2</sup>	8,10	6.1.5
Plan area of all recesses forward of $L_H/2$	$A_{RF}$	m <sup>2</sup>	0,00	6.1.5
Ratio of total recess plan area to (length x beam)	$A_R/L_H B_H$	"-	0,18	6.1.5
Design category possible (A if < 0,2, B if < 0,3)			<b>A</b>	6.1.5
Ratio of forward recess plan area to (length x beam)	$A_{RF}/L_H B_H$	"-	0,00	6.1.5
Design category possible (A if < 0,1, B if < 0,15)			<b>A</b>	6.1.5
Overall design category possible on Recess limitations:			<b>A</b>	

ISO 12217-2 CALCULATION WORKSHEET No. 3		DOWNFLOODING	
<b>Downflooding Openings:</b>		<b>COMPLETE FOR LDC ONLY</b>	
<b>Question</b>			
Have all appropriate downflooding openings been identified?	YES/NO	YES	6.2.1.1
Do all closing appliances satisfy ISO 12216?	YES/NO	YES	6.2.1.2
Opening type appliances are not fitted below 0,2 m above waterline unless they comply with ISO 9093 or ISO 9094?	YES/NO	YES	6.2.1.3
Are all openings fitted with closing appliances? (except openings for ventilation and engine combustion)	YES/NO	YES	6.2.1.5
Categories possible: A or B if all are YES, C or D if first three are YES		<b>A or B</b>	6.2.1

<b>Downflooding Angle:</b>			<b>COMPLETE FOR LDC &amp; MOC</b>	
Item	Symbol	Units		
Required value:				
Cats A + B = 40°, Cat. C = 35°, Cat. D = 30°	$\varnothing_{D(R)}$	degrees	40	Table 3
Actual Downflooding Angle: any opening at $m_{MOC}$	$\varnothing_{DA}$	degrees	120	3.3.2
If $m_{LDC} / m_{MOC} > 1,15$ then also at $m_{LDC}$	$\varnothing_{DA}$	degrees	118	3.3.2
Method used to determine $\varnothing_{DA}$ :			THEORETICAL	Annex B
Category possible on Downflooding Angle $\varnothing_{DA}$ :			<b>A or B</b>	6.2.3
Actual Downflooding Angle: to non-quick-draining cockpit	$\varnothing_{DC}$	degrees	120,00	3.3.2
Actual Downflooding Angle: to main hatchway	$\varnothing_{DH}$	degrees	123,00	3.3.2

<b>Downflooding height:</b>			<b>COMPLETE FOR LDC ONLY</b>	
Requirement	Basic requirement	Reduced value for small openings		
applicable to	options 1 to 6 and 8	options 1 to 6 and 8, but only if figures are used		
Ref.	6.2.2.2 a)	6.2.2.2 b)		
Obtained from Figure 2 or annex A?	<b>FIGURE 2</b>	= basic x 0,75		
Maximum area of small openings ( $50L_H^2$ ) [mm <sup>2</sup> ] =	7260,125			
Required Downflooding Height $H_{D(R)}$ (m)				
Fig. 2 / annex A Category A	0,709	0,532		
Fig. 2 / annex A Category B	0,709	0,532		
Fig. 2 / annex A Category C	0,709	0,532		
Fig. 2 / annex A Category D	0,400	0,300		
Actual Downflooding Height $h_D$ Ref.: 6.2.2.1	1,300	0,710		
Design Category possible	<b>A</b>	<b>A</b>		
Overall Design Category possible on Downflooding Height = lowest of above				<b>A</b>

NOT NEEDED

Calculation using Annex A assuming use of option..... **1**

Item	Symbol	Units	Opening 1	Opening 2	Opening 3	Opening 4
<b>Position of openings:</b>						
Least longitudinal distance from bow/stern	$x$	m				
Least transverse distance from gunwale	$y$	m				
$F_1 = \text{greater of } (1 - x/L_H) \text{ or } (1 - y/B_H) =$	$F_1$	-	1,000	1,000		
<b>Size of openings:</b>						
Combined area of openings to top of any downflooding opening	$a$	mm <sup>2</sup>				
Longitudinal distance of opening from tip of bow	$x'_D$	m				
Limiting value of $a = (30L_H)^2$		mm <sup>2</sup>	130682	130682		
If $a \geq (30L_H)^2$ , $F_2 = 1,0$ If $a < (30L_H)^2$ , $F_2 = 1 + (x'_D/L_H) * ((\sqrt{a}) / (75L_H)) - 0,4$	$F_2$	-	1,000	1,000	1,000	1,000
<b>Size of recesses:</b>						
Volume of Recesses which are not Self- Draining in accordance with ISO 11812	$V_R$	m <sup>3</sup>				
Freeboard amidships (see 3.4.6)	$F_M$	m				
$k = V_R / (L_H B_H F_M)$	$k$	-	#DIV/0!	#DIV/0!	#DIV/0!	#DIV/0!
Opening is:						
If opening is not a recess, $F_3 = 1,0$ If recess is quick-draining, $F_3 = 0,7$ If recess is not quick-draining $F_3 = (0,7 + k^{0.5})$	$F_3$	-	#DIV/0!	#DIV/0!	#DIV/0!	#DIV/0!
<b>Displacement:</b>						
Loaded displacement volume (see 3.5.7)	$V_D$	m <sup>3</sup>	9,0732			
$B = B_H$ for monohulls, $B_{WL}$ for multihulls	$B$	m	$B = BH =$	3,71	3,150	
$F_4 = [(10V_D)/(L_H B^2)]^{1/3}$	$F_4$	-	0,9121			
<b>Floation:</b>						
For boats using options 3 or 4, $F_5 = 0,8$ For all other boats, $F_5 = 1,0$	$F_5$	-	1			
<b>Required Calc. Height:</b> = $F_1 F_2 F_3 F_4 F_5 L_H / 15$						
Required Downflooding Height with limits applied (see Annex A Table A.1)	Category A	$h_{D(R)}$	m	#DIV/0!	#DIV/0!	#DIV/0!
	Category B	$h_{D(R)}$	m	#DIV/0!	#DIV/0!	#DIV/0!
	Category C	$h_{D(R)}$	m	#DIV/0!	#DIV/0!	#DIV/0!
	Category D	$h_{D(R)}$	m	#DIV/0!	#DIV/0!	#DIV/0!
<b>Measured Downflooding Height:</b>		$h_D$	m			
<b>Design Category possible:</b>			#DIV/0!	#DIV/0!	#DIV/0!	#DIV/0!
Lowest of above =						<b>NOT NEEDED</b>

ISO 12217-2 CALCULATION WORKSHEET No.			STABILITY INDEX (STIX)			
Stability Index (STIX):			COMPLETE BOTH FOR mMOC & mLDC			
Factor	Item	Symbol	Units	At mMOC	At mLDC	Ref.
FDS (6.4.2)	Positive area under GZ curve to $\phi_V$ or $\phi_D$ (see text)	$A_{GZ}$	m deg.	69,8	69,8	6.4.2002
	Length of hull	$L_H$	m	12,05	12,05	3.4.1
	Factor as calculated = $A_{GZ} / (15,81 L_H^{0,5})$	FDS	-	1,271833	1,271833	6.4.2
	FDS when limited to the range 0,5 to 1,5	FDS	-	1,271833	1,271833	6.4.2
FIR (6.4.3)	Angle of vanishing stability	$\phi_V$	degree	129	129	3.4.10
	If $m < 40000$ , $FIR = \phi_V / (125 - m / 1600)$ If $m \geq 40000$ , $FIR = \phi_V / 100$	If FIR	-	1,073853	1,082328	6.4.3
	FIR when limited to the range 0,4 to 1,5	FIR	-	1,073853	1,082328	6.4.3
FKR (6.4.4)	Righting lever at 90° heel	$GZ_{90}$	m	0,56	0,56	6.4.4
	Nominal sail area (see ISO 8666)	$A_S$	m <sup>2</sup>	71,80	71,80	3.4.8
	Height of centre of area of $A_S$ above waterline at m	$h_{CE}$	m	7,28	7,28	6.4.4
	calculate $F_R = (GZ_{90} m) / (2 A_S h_{CE})$	$F_R$	-	4,1756	4,9818	
	If $F_R \geq 1,5$ , $FKR = (0,875 + 0,0833 F_R)$ If $F_R < 1,5$ , $FKR = (0,5 + 0,333 F_R)$ If $GZ_{90} < 0$ , $FKR = 0,5$	If FKR	-	1,2228	1,2900	6.4.4
FKR when limited to the range 0,5 to 1,5	FKR	-	1,2228	1,2900	6.4.4	
FDL (6.4.5)	Length waterline	$L_{WL}$	m	9,96	9,96	3.4.2
	Length base size $L_{BS} = (2 L_{WL} + L_H) / 3$	$L_{BS}$	m	10,65667	10,65667	6.4.5
	Calculate $F_L = (L_{BS} / 11)^{0,2}$	$F_L$	-	0,9937	0,9937	6.4.5
	Calculate $FDL = \{0,6 + [15 m_{MSC} F_L / (L_{BS}^3 (333 - 8 L_{BS}))]\}$	FDL	-	0,9937	1,0307	6.4.5
	FDL when limited to the range 0,75 to 1,25	FDL	-	0,9937	1,0307	6.4.5
FBD (6.4.6)	Beam of hull	$B_H$	m	3,71	3,71	3.4.3
	Beam waterline	$B_{WL}$	m	3,15	3,15	3.4.4
	Calculate $F_B = 3,3 B_H / (0,03 m)^{1/3}$	$F_B$	-	1,9872	1,8736	6.4.6
	if $F_B > 2,20$ $FBD = [13,31 B_{WL} / (B_H F_B^3)]^{0,5}$ if $F_B < 1,45$ $FBD = [B_{WL} F_B^2 / (1,682 B_H)]^{0,5}$ Otherwise $FBD = 1,118 (B_{WL} / B_H)^{0,5}$	FBD	-	1,0302	1,0302	6.4.6
	FBD when limited to the range 0,75 to 1,25	FBD	-	1,0302	1,0302	6.4.6
FWM (6.4.7)	Downflooding angle = lesser of $\phi_{DC}$ and $\phi_{DH}$	$\phi_D$	degrees	120	120	3.3.2
	If $\phi_D \geq 90^\circ$ (see Worksheet 3) then $FWM = 1,0$ If $\phi_D < 90^\circ$ then: $FWM = v_{AW} / 17$					
	Righting lever at downflooding angle	$GZ_D$	m	69,8	69,8	6.4.7
	Lever from centre of sail area to underwater profile	$h_{CE} + h_{LP}$	m	8,1	8,1	6.4.7
	Calculate wind speed at which serious flooding occurs = $\{13 m_{MSC} GZ_D / [A_S (h_{CE} + h_{LP})  \cos \phi_D ^{1,3}]\}^{0,5}$	$v_{AW}$	m/s	114,1255	124,6568	6.4.7
	If $\phi_D < 90^\circ$ , $FWM = v_{AW} / 17$ ; if $\phi_D \geq 90^\circ$ , $FWM = 1,0$	FWM	-	1	1	6.4.7
FWM when limited to the range 0,5 to 1,0	FWM	-	1	1	6.4.7	
FDF (6.4.8)	Downflooding Angle to non-quick-draining cockpit	$\phi_{DC}$	degrees	120	120	3.3.2
	Downflooding Angle to main access hatch	$\phi_{DH}$	degrees	120	120	3.3.2
	total area of openings for finding $\phi_{DA1} = (50 L_H^2)$		mm <sup>2</sup>	7260,125		6.4.8
	Downflooding angle until above area is immersed	$\phi_{DA1}$	degrees	120	120	6.4.8
	Smallest of the above three angles	$\phi_D$	degrees	120	120	6.4.8
	Then $FDF = \phi_D / 90$			1,333333	1,333333	6.4.8
	FDF when limited to the range 0,5 to 1,25	FDF	-	1,25	1,25	6.4.8

NB: Final value to be used for each factor is the figure in the shaded box.



**ISO 12217-2 CALCULATION WORKSHEET No. 6 VANISHING STABILITY**

<b>Angle of vanishing stability:</b>		<b>COMPLETE BOTH FOR mMOC &amp; mLDC</b>			
Item	Symbol		At mMOC	At mLDC	Ref.
Mass in relevant condition	$m$	kg	7795,00	9300,00	3.5.3
Categories possible on mass (A > 3000 kg; B > 1500 kg)			<b>A</b>	<b>A</b>	Table 4
<b>Required value of angle of vanishing stability:</b>					6.3.1
Category A = $(130 - m/500)$ but $\geq 100^\circ$	$\phi_{V(R)}$	degree	114,41	111,4	Table 4
Category B = $(130 - m/200)$ but $\geq 95^\circ$	$\phi_{V(R)}$	degree	95	95	
Category C = $90^\circ$	$\phi_{V(R)}$	degree	90	90	
Category D = $75^\circ$	$\phi_{V(R)}$	degree	75	75	
Actual angle of vanishing stability:	$\phi_v$	degree	129	127	3.4.10
<b>Category possible on angle of vanishing stability:</b>			<b>A</b>	<b>A</b>	6.3.1

**Alternative for Design Category A or B only:**

If $\phi_v \geq 90^\circ$ (Category A) or $\geq 75^\circ$ (Category B), apply worksheet 9 as an alternative to the above? YES/NO	NO	<a href="#">WS 9</a>
---	----	----------------------

ISO 12217-2 CALCULATION WORKSHEET No. 7 KNOCKDOWN-RECOVERY TEST				
Design Categories C and D only		NOT NEEDED		
Item	Symbol	Cat. C	Cat. D	Ref.
Method: experimental / theoretical				
<b>Experimental method:</b>				
Crew Limit	CL	8	8	3.6.3
Weight needed for experiment:		600	600	
Is boat prepared and persons positioned as 6.5.1 and 6.5.2 YES / NO?				6.5.1 6.5.2
Is water or weight used instead of persons, if so which?				6.5.2
Masthead taken to		Waterline	Horizontal	6.5.3 6.5.4
Masthead held in position for		60 sec.	10 sec.	6.5.3 6.5.4
Boat recovers when released YES / NO?				6.5.3 6.5.4
Boat floats so it can be pumped or bailed out YES / NO?				6.5.4
<b>If boat achieves YES to each of above, Design Category is OK</b>		<b>NOT NEEDED</b>	<b>NOT NEEDED</b>	
<b>Alternative theoretical method:</b>				
Is GZ positive at heel angle defined above? YES / NO?				6.5.5
<b>Design Category recommended by the builder:</b>		<b>NOT NEEDED</b>		

ISO 12217-2 CALCULATION WORKSHEET No. 8			WIND STIFFNESS TEST		
Design Categories C and D only			NOT NEEDED		
Choose method:					
Experimental method:			NOT NEEDED		
Item	Symbol	Units	Un- reefed	Reefed	Ref.
Boat prepared and weight positioned as 6.6.2	YES / NO?				6.6.2
Final tension in pull-down line	$T$	kg			6.6.4
Perpendicular lever between pull-down and mooring lines	$h$	m			6.6.4 Figure 5
Final angle of heel observed	$\phi_T$	degrees			6.6.4
Beam of hull	$B_H$	m	3,71		3.4.3
Actual profile projected area of sails	$A'_S$	m <sup>2</sup>			3.4.9
Upright lever from centre of sail area to underwater profile	$h_{CE}+h_{LP}$	m			6.6.5 Figure 6
Calculated wind speed = $\sqrt{((13hT+390B_H)/(A'_S(h_{CE}+h_{LP})(\cos\phi_T)^{1.3}))}$	$V_W$	m/s	#DIV/0!	#DIV/0!	6.6.5
Design Category given according to Table 6			NOT NEEDED		Table 6
<b>NB:</b> Warning labels must be affixed to boat if category is based on reefed sail plan.					
Alternative theoretical method:			NOT NEEDED		
Item	Symbol	Units	Un- reefed	Reefed	Ref.
Righting moment curve increased by one crew to windward	YES / NO?				6.6.6
Option (from Worksheet 2) being used (only 5 & 6)			1		Table 2
Design Category intended			NOT NEEDED	NOT NEEDED	
Relevant calculation wind speed taken from Table 6	$V_W$	m/s	NOT NEEDED	NOT NEEDED	Table 6
Actual profile projected area of sails	$A'_S$	m <sup>2</sup>			3.4.9
upright lever from centre of sail area to underwater profile	$h_{CE}+h_{LP}$	m			6.6.5 Figure 6
Calculate: $0,75 V_W^2 A'_S (h_{CE} + h_{LP})$	$M_{W0}$	Nm	#VALUE!	#VALUE!	
From righting moment curve and wind heeling curve [ = $M_{W0} (\cos\phi)^{1.3}$ ] resulting angle of heel =	$\phi$	degrees	40	40	6.6.6
is $\phi < \phi_{DA}$ ( see Worksheet 3) and $< 45^\circ$ ?			YES		6.6.3
if YES, Design Category given:			NOT NEEDED	NOT NEEDED	
<b>NB:</b> Warning labels must be affixed to boat if Category is based on reefed sail plan.					

Annex D

NOT NEEDED

**Objective:** to show that the buoyancy available from the hull structure, fittings and flotation elements equals or exceeds that required to support the loaded boat.

exceeds that required to support the loaded boat.	Mass kg	Density kg/m <sup>3</sup>	Volume m <sup>3</sup> = mass/density	Ref.
<b>Hull structure:</b>				
GRP laminate		1 500		Table D.1
Foam core materials		50		Table D.1
Balsa core materials		150		Table D.1
Plywood		600		Table D.1
Other timber (type = )				Table D.1
Permanent ballast (type = )				Table D.1
Fastenings and other metalwork (type = )				Table D.1
Windows ( glass / plastic )				Table D.1
<b>Engines and other fittings and equipment:</b>				
Diesel engine(s)		5 000		Table D.1
Petrol engine(s)		4 000		Table D.1
Outboard engine(s)		3 000		Table D.1
Sail-drive or stern-drive strut(s)		3 000		Table D.1
Mast(s) and spar(s) (material = alloy / spruce )				Table D.1
Stowed sails and ropes		1 200		Table D.1
Food and other stores		2 000		Table D.1
Miscellaneous equipment		2 000		Table D.1
Non-integral fuel tank(s) (material = )				Table D.1
Non-integral water tank(s) (material = )				Table D.1
<b>Fuel tank(ds)</b>				
<b>Gross volumes of fixed tanks and air containers:</b>				D.2.2
Fuel tank(s)			2,00	D.2.2
Water tank(s)				D.2.2
Other tank(s)				D.2.2
Air tanks or containers meeting the requirements of annex E				D.2.2
<b>Total volume of hull, fittings and equipment, <math>V_B = \text{sum of all above volumes}</math></b>			2,00	D.2.2
Loaded displacement mass	$m_{LDC}$	kg	9300,00	3.5.6
Calculate ratio $m_{LDC} / V_B =$			4650	D.2.3
Foption 8,	$m_{LDC} / V_B < 850$	YES / NO?	NOT NEEDED	D.2.3
For options 4 and 6,	$m_{LDC} / V_B < 1\ 000$	YES / NO?	NOT NEEDED	D.2.3

Design Categories C and D only (opt 7)

NOT NEEDED

**Objective:** to demonstrate that a boat can be returned to the upright after a capsize by the actions of the crew using their body action and/or righting devices purposely designed and permanently fitted to the boat, that it will subsequently float, and to verify that the recommended minimum crew mass is sufficient for the recovery method used.

Item	Units	Value	Ref.
Minimum number of crew required	persons	2	6.8.7
Minimum mass of crew required	kg	150	6.8.7
Is boat prepared as 6.8.2 to 6.8.5?	YES / NO?		6.8.2 to 6.8.5
Does boat float for > 5 min when fully capsized?	YES / NO?		6.8.6
Time required to right the boat (least of 1 to 3 attempts)	minutes		6.8.8
Is this time less than 5 minutes?	YES / NO?	YES	6.8.8
With one 75kg person aboard, boat floats so it can be pumped or bailed out? YES / NO?			6.8.10
With full Crew Limit aboard, without bailing, boat floats approx. level with at least 2/3 periphery showing, for more than 5 min? YES / NO?			6.8.11

**INFORMATION FOR OWNER'S MANUAL:**

Likelihood of capsize occurring in normal use:

Righting technique which is most successful:

Minimum number of crew required:	2	Minimum mass of crew required [kg] :	150
----------------------------------	---	--------------------------------------	-----

Design Category recommended by the builder:

NOT NEEDED

ISO 12217-2 CALCULATION WORKSHEET No. 11

MULTIHULL SIZE FACTOR

NOT NEEDED		Boat is a (catamaran/trimaran) :			
Intended Design Category:			A		
Item	Symbol	Units	Value	Ref.	
Minimum operating mass	$m_{MOC}$	kg	7795,00	3.5.3	
Length of hull (as ISO 8666)	$L_H$	m	12,05	3.4.1	
Beam between centres of buoyancy of sidehulls	$B_{CB}$	m	8	3.4.5	
$L/B = \dots$ (for CATAMARANS: $= L_H / B_{CB}$ ... For TRIMARANS: $= 2 L_H / B_{CB}$ )			NOT NEEDED	Table 7	
Required multihull size factor (from Table 7) for intended Design Category			#VALUE!	Table 7	
Actual multihull size factor $= 1,75 m_{MOC} \sqrt{L_H B_{CB}} =$			133934,57	7,7	
Actual value exceeds required value YES / NO?			#VALUE!	7,7	
Design Category assigned:			#VALUE!	7,7	

ISO 12217-2 CALCULATION WORKSHEET No. 12			STABILITY INFORMATION		
Preliminary information			NOT NEEDED		
Item			Value	Ref.	
Boat is a catamaran or a trimaran?			0	3.1.3 , 3.1.4	
Method of determination: calculation using Annex G, or sailing trials?				7.4 b)	
Calculation using annex G:			NOT NEEDED		
Item	Symbol	Units	Minimum operating condition (MOC)	Loaded displacement condition (LDC)	Ref.
Mass of craft (for load condition under consideration)	$m$	kg	7795,00	9300,00	
Length of hull (as ISO 8666)	$L_H$	m	12,05	12,05	3.4.1
Length waterline (as ISO 8666)	$L_{WL}$	m	9,96	9,96	3.4.2
Beam waterline (as ISO 8666)	$B_{WL}$	m	3,15	3,15	3.4.4
Beam between centres of buoyancy of sidehulls	$B_{CB}$	m	8	8	3.4.5
Draught of canoe body at the appropriate loading condition according to ISO 8666	$T_C$	m			3.4.7
Height of CG above bottom of canoe body	VCG	m			G.2.1
Total waterplane area of all hulls at design waterline	$A_W$	m <sup>2</sup>			G.2.2
Estimated angle of heel of maximum GZ (for catamarans only = $\tan^{-1} (m / (254 L_{WL} B_{WL} B_{CB}))$ )	$\phi_{GZmax}$	degrees	0,122	0,145	G.2.1
Calculate ratio $(L_H + L_{WL}) / B_{CB} =$			2,752	2,752	G.1
<b>NB:</b> where $(L_H + L_{WL}) / B_{CB} \geq 4$ , only limiting moment in roll is considered where $(L_H + L_{WL}) / B_{CB} < 4$ , the lesser value of limiting moment in roll and pitch is used.					
Limiting moment in roll: (for catamarans only) = $9,4m[(0,5B_{CB}\cos\phi_{GZmax}) - (VCG \sin\phi_{GZmax})]$	LM <sub>R</sub>	Nm	NOT NEEDED	NOT NEEDED	G.2.1
Limiting moment in pitch: (for catamarans only = $2,45 m A_W / B_{WL}$ )	LM <sub>P</sub>	Nm	NOT NEEDED	NOT NEEDED	G.2.2
Limiting moment to be used:	LM	Nm	0	0	G.1
<b>Calculated wind speed limit for following sail combinations</b>  $= 1,6 \cdot \sqrt{\frac{(LM)}{A'_S (h_{CE} + h_{LP})}}$	<b>Rig</b>	<b>A'<sub>S</sub> (m<sup>2</sup>)</b>	<b>h<sub>CE</sub>+h<sub>LP</sub> (m)</b>	<b>v<sub>w</sub> (m/s)</b>	
	light weather			#DIV/0!	#DIV/0!
	working sails			#DIV/0!	#DIV/0!
	first reef			#DIV/0!	#DIV/0!
	second reef			#DIV/0!	#DIV/0!
storm rig				#DIV/0!	#DIV/0!
INFORMATION ON STABILITY SUPPLIED IN BOAT DOCUMENTS?			YES		

## COMPLETE THE TABLE

Design description:

YD-40

Design category intended:	<b>A</b>		Crew limit:	8	Date:	18.9.2014
Sheet	Item		Symbol	Unit	Value	
1	Length of hull: (as in ISO 8666)		$L_H$	m	12,05	
	<b>Mass:</b>					
	Maximum total load		$m_{MTL}$	kg	2050,00	
	Light craft condition mass		$M_{LCC}$	kg	7250,00	
	Loaded displacement mass = $m_{LCC} + m_{MTL}$		$M_{LDC}$	kg	9300,00	
	Minimum operating mass		$m_{MOC}$	kg	7795,00	
1	Is boat sail or non-sail? SAIL /		NON/SAIL		SAIL	
2	<b>Option selected:</b>		<u>1</u>			
3	<b>Downflooding openings:</b> are all requirements met?		<b>Unit</b>	<b>Required</b>	<b>Actual</b>	<b>Pass/Fail</b>
	Downflooding angle: to any opening, $\phi_{DA}$		degree	> 40	120	PASS
	to non-quick-draining cockpit, $\phi_{DC}$		degree	//////////	120	//////////
	to main access hatchway, $\phi_{DH}$		degree	//////////	123	//////////
3 and 4	<b>Downflooding height:</b> Worksheet employed for basic height					
	basic requirement		m	$\geq 0,709$	1,30	PASS
	reduced height for small openings (sheet 3 only)		m	$\geq 0,532$	0,71	PASS
5 and 6	<b>Stability index:</b> (options 1 + 2 only) STIX =		—	> 32	51	PASS
6	Angle of vanishing stability: (options 1 + 2 only) $\phi_v =$		degree	114,41	129	PASS
7	<b>Knockdown-recovery test:</b>					//////////
	method used = experimental or theoretical?				0	
	Design Category =				NOT NEEDED	PASS
8	<b>Wind stiffness test:</b> (options 5 + 6 only)		Method used:		0	
	Design Category =				NOT NEEDED	PASS
	was reefed sail area used? (i.e.: are warning labels required?)				NOT REEFED	//////////
9	<b>Flotation requirement:</b> ratio $m_{LDC}/V_B =$ (options 4, 6 + 8 only)		kg/m <sup>3</sup>	< NOT NEEDED	4650	PASS
10	<b>Capsize recovery test:</b> (option 7 only) are all requirements met?					PASS
	Design Category recommended by the builder				NOT NEEDED	//////////
11	<b>Multihull size factor:</b> (option 8 only) size factor			> NOT NEEDED	133935	PASS
12	<b>Stability information:</b> (option 8 only) Info. document supplied like Table F.1 YES/NO?					YES
NB: Boat must pass all requirements applicable to option to be given intended Design Category.						
Assessed by:	Tomislav Prosinčki		Design category given:		<b>A</b>	



# **PRILOG 3.**

Tablični kalkulator

**ISO 12217-3**

primjer praznih tablica

ISO 12217-3 CALCULATION WORKSHEET No.1		BOATS OF HULL LENGTH LESS THAN 6 m		
CALCULATION WORKSHEET No. 1		GENERAL INFORMATION		
Design:				
Design Category intended:		Monohull / Multihull:		
Item	Symbol	Units	Value	Ref.
Length of hull	$L_H$	m		ISO 8666
Mass:				
<b>Maximum total load:</b>				3.3.2
Desired Crew Limit	CL	—		3.4.2
<b>Mass of:</b>				
desired Crew Limit at 75 kg each		kg	0,00	
provisions + personal effects		kg		
fresh water		kg		
fuel		kg		
other liquids carried aboard		kg		
stores, spare gear and cargo (if any)		kg		
optional equipment and fittings		kg		
not included in basic outfit		kg		
inflatable liferaft		kg		
other small boats carried aboard		kg		
margin for future additions		kg		
<b>Maximum total load = sum of above masses</b>	$m_{MTL}$	kg	0,00	3.3.2
<b>Light craft condition mass</b>	$m_{LCC}$	kg	100,00	3.3.1
<b>Loaded displacement mass = <math>m_{LCC} + m_{MTL}</math></b>	$m_{LDC}$	kg	100,00	3.3.3
<b>Is boat sail or non-sail?</b>				
nominal sail area	$A_S$	m <sup>2</sup>	0,00	ISO 8666
sail area / displacement ratio = $A_S / (m_{LDC})^{2/3}$		-	0,000	5.2
CLASSIFIED AS (non-sail if $A_S / (m_{LDC})^{2/3} < 0,07$ )	SAIL / NON-SAIL ?		NON-SAIL	5.2
<b>GO TO WORKSHEET No. 2</b>				

ISO 12217-3 CALCULATION WORKSHEET No.2

NON-SAIL TESTS TO BE APPLIED

COMPLETE THE TABLES BELOW

Question	Answer	Ref.
Is boat fully decked? (see definition in Ref.) YES / NO?		3.1.5
Is boat partially decked? (see definition in Ref.) YES / NO?		3.1.6

Item	Symbol	Units	Value	Ref.
Length of Hull	L <sub>H</sub>	m	0,00	ISO 8666
Beam of Hull	B <sub>H</sub>	m		ISO 8666
Beam on waterline	B <sub>WL</sub>	m		ISO 8666

Option No.	1 <sup>a</sup>	2	3 <sup>a</sup>	4	5	6 <sup>a</sup>
Applicable to length of hull	Up to 6,0 m		From 4,8 m up to 6,0 m			
Design categories possible	C and D	C and D	D	C and D	D only	C and D
Applicable to engine powers of	Any amount	Any amount	≤ 3 kW	Any amount	Any amount	Any amount
Applicable to the following types of engine installation	Any	Any	Any	Any	Any	Inboard engines only
Decking or covering	Any amount	Fully decked <sup>b</sup>	Any amount	Partially decked <sup>c</sup>	Any amount	Any amount
Downflooding height test	4 <sup>d</sup> or 5 <sub>d</sub>	4 or 5	4 or 5	4 or 5	4 or 5	4 or 5
Offset load test	6a, 6b or 6c	6a, 6b or 6c	—	6a, 6b or 6c	6a, 6b or 6c	6a, 6b or 6c
Flotation standard	Level	—	—	—	—	Basic
Flotation test	7	—	—	—	—	7 or 8
Flotation elements	Annex C	—	Annex C	—	—	Annex C
Capsize recovery test	—	—	9	—	—	—

<sup>a</sup> Boats using options 1, 3 and 6 are considered to be susceptible to swamping when used in their design category.

<sup>b</sup> This term is defined in 3.1.5.

<sup>c</sup> This term is defined in 3.1.6.

<sup>d</sup> This test is not required to be applied if, when swamped during Test 6.4, the boat supports an equivalent dry mass of 33 % of the maximum total load, or if the boat does not take on water when heeled to 90° from the upright in light craft condition

SELECT OPTION

OPTION SELECTED:

0

## NOT NEEDED

Question		Answer	Ref.
Is boat fully decked? (see definition in Ref.)		YES / NO?	3.1.5
Is boat a MONOHULL?		NO	
Length of hull	$L_H$	m	0,00
Mass in the light craft condition	$m_{LCC}$	kg	100,00
<b>NB:</b> If the boat can also be used as a non-sailing boat, it must also complete the corresponding tests required according to Worksheet 2.			

Choose any ONE of the following options, and use the worksheets indicated for that option.

Option No.	7 <sup>a</sup>	8 <sup>a</sup>	9 <sup>a</sup>	10	11
Categories possible	C and D	C and D	C and D	C and D	C and D
Applicable to hull types	All	Monohull only	Monohull only	All	All
Decking or covering	Any amount	Any amount	Any amount	Fully decked	Fully decked
Downflooding height test	—	—	—	4 or 5	4 or 5
Flotation standard cat C	—	Level	Level <sup>b</sup>	—	—
Flotation standard cat D	—	Basic	Basic <sup>b</sup>	—	—
Flotation test category C	—	7	7 <sup>b</sup>	—	—
Flotation test category D	—	7 or 8	7 <sup>b</sup> or 8 <sup>b</sup>	—	—
Flotation elements	Annex C	Annex C	Annex C	—	—
Capsize recovery test	9	—	—	—	—
Knockdown recovery test	—	10	—	10	—
Wind stiffness test	—	—	11	—	11
<p>a Boats using options 7, 8 and 9 are considered to be susceptible to swamping when used in their design category, excepting those boats using option 9 and covered by the exemptions given in footnote b.</p> <p>b Flotation testing is not required for boats satisfying the exemptions given in 7.3.1 or 7.3.2.</p>					

<b>SELECT OPTION:</b>	
-----------------------	--

<b>OPTION SELECTED:</b>	
-------------------------	--

<b>NOT NEEDED - BOAT IS NON-SAIL</b>
--------------------------------------

Question	Answer	Ref.
Are conditions for exemption for category C satisfied?	YES / NO?	7.3.1
Are conditions for exemption for category D satisfied?	YES / NO?	7.3.2

ISO 12217-3 CALCULATION WORKSHEET No. 4				DOWNFLOODING		
<b>Downflooding Openings:</b>				<b>COMPLETE THE TABLE</b>		
<b>Question</b>				<b>Answer</b>	<b>Ref.</b>	
Engine inboard or outboard?						
Have all appropriate downflooding openings been identified? YES/NO					6.2.1.1	
Do all closing appliances satisfy ISO 12216? YES/NO					6.2.1.2	
Opening type appliances are not fitted below 0,2 m above waterline unless they comply with ISO 9093 or ISO 9094? YES/NO					6.2.1.3	
<b>Categories possible:</b> C or D if all three are YES				<b>FAIL</b>	6.2.1	
<b>Downflooding Height :</b> (alternatively use Worksheet 5)				<b>COMPLETE THE TABLE</b>		
<b>Requirement</b>		<b>Basic requirement</b>	<b>Reduced value for small openings</b>	<b>Reduced value at outboard</b>	<b>Increased value at bow</b>	
applicable to		options 1-6, 10, 11	options 1-6, 10, 11 but only if figures are used	options 1, 3	options 1, 3, 5, 6	
Ref.		6.2.2.2 a)	6.2.2.2 e)	6.2.2.2 c)	6.2.2.2 b)	
Obtained from Fig. 2 or annex A?			= basic x 0,75	= basic x 0,80	= basic x 1,15	
Maximum area of small openings ( $50L^2_H$ ) (mm <sup>2</sup> ) =				////////	////////	
Required Downflood Height $h_{D(R)}$ (m)	Fig. 2 / annex A	Category C	#N/A	NOT NEEDED	NOT NEEDED	NOT NEEDED
	Fig. 2 / annex A	Category D	#N/A	NOT NEEDED	NOT NEEDED	NOT NEEDED
Actual Downflooding Height $h_D$ (m)						
Design Category possible		#N/A	NOT NEEDED	NOT NEEDED	NOT NEEDED	
<b>Design Category possible</b> on Downflooding Height = lowest of above					<b>#N/A</b>	
<b>Downflooding Height: Outboard boats when starting:</b>				<b>NOT NEEDED</b>		
<b>Question</b>				<b>Answer</b>	<b>Ref.</b>	
Does person forward of engine weigh more than 75 kg? YES/NO					6.2.3	
Does mass of engine(s) fitted comply? YES/NO					6.2.3	
Is least height from waterline to flood point greater than 0,1 m? YES/NO					6.2.3	
<b>NB:</b> All boats fitted with externally mounted outboard engines must achieve YES to all the above.						

ISO 12217-3 CALCULATION WORKSHEET No. 5

DOWNFLOODING HEIGHT

NOT NEEDED

Calculation using Annex A assuming use of option .....		0					
Item	Symbol	Units	Opening 1	Opening 2	Opening 3	Opening 4	
<b>Position of openings:</b>							
Least longitudinal distance from bow/stern	$x$	m					
Least transverse distance from gunwale	$y$	m					
$F_1 = \text{greater of } (1 - x/L_H) \text{ or } (1 - y/B_H) =$	$F_1$	—	#DIV/0!	#DIV/0!	#DIV/0!	#DIV/0!	
<b>Size of openings:</b>							
Combined area of openings to top of any downflooding opening	$a$	mm <sup>2</sup>					
Longitudinal distance of opening from tip of bow	$x'_D$	m					
Limiting value of $a = (30L_H)^2$		mm <sup>2</sup>	0	0	0	0	
If $a \geq (30L_H)^2, F_2 = 1,0$							
If $a < (30L_H)^2, F_2 = 1 + (x'_D/L_H)[(\sqrt{a})/(75L_H) - 0,4]$	$F_2$	—	1,000	1,000	1,000	1,000	
<b>Size of recesses:</b>							
Volume of Recesses which are not self-draining in accordance with ISO 11812	$V_R$	m <sup>3</sup>	5,000	5,000	5,000	5,000	
Freeboard amidships (see ISO 8666)	$F_M$	m	2,000	2,000	2,000	2,000	
$k = V_R / (L_H B_H F_M)$	$k$	—	#DIV/0!				
Opening is:							
If opening is not a recess, $F_3 = 1,0$ If recess is quick-draining, $F_3 = 0,7$ If recess is not quick-draining $F_3 = (0.7 + k^{0.5})$	$F_3$	—	#DIV/0!	0,700	0,700	0,700	
<b>Displacement:</b>							
Loaded displacement volume (= $m_{LDC} / 1025$ )	$\nabla$	m <sup>3</sup>	0,10				
$B = B_H$ for monohulls, $B_{wl}$ for multihulls	$B$	m	error				
$F_4 = [(10\nabla)/(L_H \cdot B^2)]^{1/3}$	$F_4$	—	#VALUE!				
<b>Flotation:</b>							
For boats using options 1 or 3, $F_5 = 0,8$ For boats using option 4, $F_5 = 1,25$ For boats using option 6, $F_5 = 0,9$ For all other boats, $F_5 = 1,0$	$F_5$	—	1,000				
<b>Required Calc. Height: = <math>F_1 F_2 F_3 F_4 F_5 L_H / 15</math></b>							
Required Downflooding Height with limits applied (see Annex A, Table A.1)	Category C	$h_{D(R)}$	m	#DIV/0!	#DIV/0!	#DIV/0!	#DIV/0!
	Category D	$h_{D(R)}$	m	#DIV/0!	#DIV/0!	#DIV/0!	#DIV/0!
<b>Measured Downflooding Height:</b>		$h_D$	m				0,5
<b>Design Category possible:</b>				#DIV/0!	#DIV/0!	#DIV/0!	#DIV/0!
lowest of above =							NOT NEEDED

## COMPLETE THE TABLE

Question / item	Symbol	Units	Answer	Ref.
Crew Limit?	CL	—	0	3.4.2002
Length of hull	$L_H$		0,00	ISO 8666
Mass to be used to represent each person (= $15,625L_H$ but $\leq 75$ )		kg	0	6.3.2.1
Test weights or persons used?				6.3.1
Mass of items of Maximum Total Load except for crew		kg	0,00	6.3.2.2
Location of mass for one person added to one side				6.3.2.4
Least freeboard with mass added to port or starboard	$F_{R1}$	mm		6.3.2.5
Location of masses for two persons added to one side				6.3.2.6
Least freeboard with mass added to port or starboard	$F_{R2}$	mm		6.3.2.7
Location of masses for three persons added to one side				6.3.2.8
Least freeboard with mass added to port or starboard	$F_{R3}$	mm		6.3.2.8
Location of masses for four persons added to one side				6.3.2.8
Least freeboard with mass added to port or starboard	$F_{R4}$	mm		6.3.2.8
Location of masses for five persons added to one side				6.3.2.8
Least freeboard with mass added to port or starboard	$F_{R5}$	mm		6.3.2.8
Location of masses for six persons added to one side				6.3.2.8
Least freeboard with mass added to port or starboard	$F_{R6}$	mm		6.3.2.8
Location of masses for seven persons added to one side				6.3.2.8
Least freeboard with mass added to port or starboard	$F_{R7}$	mm		6.3.2.8
Location of masses for eight persons added to one side				6.3.2.8
Least freeboard with mass added to port or starboard	$F_{R8}$	mm		6.3.2.8
Least value of residual freeboard from all of above	$F_{RMIN}$	mm	0	6.3.2.10
Required residual freeboard design category C	$F_{REQ}$	mm	#N/A	Table 4
Required residual freeboard design category D	$F_{REQ}$	mm	#N/A	Table 4
<b>DESIGN CATEGORY POSSIBLE</b>			#N/A	
For boats being assessed using option 2:	<b>NOT NEEDED</b>			
Number of persons for which residual freeboard is least				6.3.2.11
Corresponding heel angle of boat		degrees		6.3.2.11
Required maximum heel angle = $10 + (24 - L_H)^3 / 600$		degrees	33,04	6.3.2.11 and Table 5
<b>PASS / FAIL?</b>			<b>NOT NEEDED</b>	

ISO 12217-3 CALCULATION WORKSHEET No. 7		FLOTATION TESTS	
COMPLETE PREPARATION TABLE AND MARKED TABLES			
Annexes B and C assumed Crew Limit (CL) = :		0	
<b>Preparation:</b>			
Item	Units	Response	Ref.
Mass equal to 25% of dry stores and equipment added? YES / NO			B.2 a)
Inboard or outboard engine fitted?			
If inboard fitted, correct engine replacement mass fitted? YES / NO			B.2 d)
Assumed outboard engine power	kW		B.2 c)
Mass fitted to represent outboard engine, controls and battery	kg		Tables B.1 and B.2
Portable fuel tanks removed and/or fixed tanks are filled? YES / NO			B.2 f)
Cockpit drains open and drain plugs are fitted? YES / NO			B.2 g)
Void compartments which are not air tanks are opened? YES / NO			B.2 i)
Total number of air tanks			
Number of integral air tanks required to be opened		SINGLE LARGEST	Table B.3
Type of test weights used: lead, 65/35 brass, steel, cast iron, aluminium			
Material factor <i>d</i>		#N/A	Table B.4
Are all preparations completed?		#N/A	

Swamped stability test ( for Level Flotation ):		NOT NEEDED	
Item	Units	Response	Ref.
Dry mass of test weights = (6 <i>d</i> CL) but ≥ (15 <i>d</i> )	kg	#N/A	Table B.6
Test weight hung from gunwale each of four positions in turn? YES / NO			B.3.1
5 min. after swamping, boat floats with less than 45° heel? PASS / FAIL		PASS	B.3.4, B.3.5.

Swamped buoyancy tests (for Level and Basic Flotation):			
Item	Units	Response	Ref.
<b>Load Test ( for Level and Basic Flotation )</b>		NOT NEEDED	
Mass of maximum total load <i>m</i> <sub>MTL</sub>	kg	0,00	3.3.2 + sheet 1
Design Category assessed		0	
Dry mass of test weights used	kg	#N/A	Table B.5
5 min. after swamping, boat floats approximately level with more than 2/3rds of periphery above water? PASS / FAIL		PASS	B.4.3.3 and B.4.4.4
<b>One Person Test (for Level Flotation boats where L<sub>H</sub> &lt; 4,8 m only)</b>		NOT NEEDED	
Test weights or actual person used?			B.4.2.1
Min. mass of test weights/person loaded on inner bottom of boat	kg	#N/A	B.4.2.1
5 min. after swamping, boat floats such that it can be pumped or bailed dry? PASS / FAIL		PASS	B.4.2.3

Flotation material and elements:		NOT NEEDED	
Item		Response	Ref.
All flotation elements comply with all the requirements? PASS / FAIL		PASS	Table C.1

<b>Design Category given:</b> NB: boat must obtain PASS in each relevant test above	PASS
---	------



**ISO 12217-3 CALCULATION WORKSHEET No. 8 BASIC FLOTATION REQUIREMENT**

**NOT NEEDED**

**Annex D**

**Objective:** to show that the buoyancy available from the hull structure, fittings and flotation elements equals or exceeds that required to support the boat as loaded for the swamped load test.

Item	Mass kg	Density kg/m <sup>3</sup>	Volume m <sup>3</sup> = mass/density	Ref.
<b>Hull structure:</b>				
GRP laminate		1 500		Table D.1
Foam core materials		50		Table D.1
Balsa core materials		150		Table D.1
Plywood		600		Table D.1
Other timber (type = )				Table D.1
Permanent ballast (type = )				Table D.1
Fastenings and other metalwork (type = )				Table D.1
Windows ( glass / plastic )				Table D.1
<b>Engines and other fittings and equipment:</b>				
Diesel engine(s)		5 000		Table D.1
Petrol engine(s)		4 000		Table D.1
Outboard engine(s)		3 000		Table D.1
Sail-drive or stern-drive strut(s)		3 000		Table D.1
Mast(s) and spar(s) (material = alloy / spruce )				Table D.1
Stowed sails and ropes		1 200		Table D.1
Food and other stores		2 000		Table D.1
Miscellaneous equipment		2 000		Table D.1
Non-integral fuel tank(s) (material = )				Table D.1
Non-integral water tank(s) (material = )				Table D.1
<b>Gross volumes of fixed tanks and air containers:</b>				
Fuel tank(s)				D.2.2
Water tank(s)				D.2.2
Other tank(s)				D.2.2
Air tanks or containers meeting the requirements of annex C				D.2.2
<b>Total volume of hull, fittings and equipment, V<sub>B</sub> = sum of all above volumes</b>			0	D.2.2
Mass of boat prepared and loaded according to B.2 and <b>B.4.3</b>	<i>m</i> <sub>TEST</sub>	kg		D.2.3
Calculate ratio <i>m</i> <sub>TEST</sub> / V <sub>B</sub> =			#DIV/0!	D.2.3
For options 1, 6, 8 or 9, <i>m</i> <sub>TEST</sub> / V <sub>B</sub> < 930	YES / NO?		<b>NOT NEEDED</b>	D.2.3

## NOT NEEDED

**Objective:** to demonstrate that a boat can be returned to the upright after a capsize by the actions of the crew using their body action and/or righting devices purposely designed and permanently fitted to the boat, that it will subsequently float, and to verify that the recommended minimum crew mass is sufficient for the recovery method used.

Item	Units	Value	Ref.
Minimum number of crew required	persons	0	6.6.5
Minimum mass of crew required	kg	0,00	6.6.5
Boat prepared as 6.6.2 to 6.6.4, and 7.4.1	YES / NO?		6.6.2 to 6.6.4 and 7.4.1
Does boat float for more than 5 min when fully capsized	YES / NO?		6.6.4
Time required to right the boat (least of 1 to 3 attempts) minutes			6.6.6
Is this time less than 5 minutes	YES / NO?	YES	6.6.6
With one 75kg person aboard, boat floats so it can be pumped or bailed out?	YES / NO?		6.6.8
With full Crew Limit aboard, without bailing, boat floats approx. level with at least 2/3rds periphery showing, for more than 5 min	YES / NO?		6.6.9
Warning Labels are attached?	YES / NO?		6.6.10 or 7.4.2

**INFORMATION FOR OWNER'S MANUAL:**

Likelihood of capsize occurring in normal use:

Righting technique which is most successful:

minimum number of crew required:	0	Minimum mass of crew required:	0,00	kg
----------------------------------	---	--------------------------------	------	----

Design Category recommended by the builder:

C

**ISO 12217-3 CALCULATION WORKSHEET No. 10 KNOCKDOWN RECOVERY TEST**

**NOT NEEDED**

Item	Symbol	Cat. C	Cat. D	Ref.
<b>Experimental method:</b> Crew Limit	CL	0	0	3.4.2
Boat prepared and persons positioned as 7.5.2 and figure 7,	YES / NO?			7.5.2
Is water or other weight used instead of persons, if so which?				7.5.2
Masthead taken to		waterline	horizontal	7.5.3, 7.5.4
Masthead held in position for		60 s	10 s	7.5.3, 7.5.4
Boat recovers when released	YES / NO?			7.5.3, 7.5.4
Boat floats so it can be pumped or bailed out	YES / NO?			7.5.4
<b>If boat achieves YES to each of above, Design Category is OK</b>		<b>FAIL</b>	<b>FAIL</b>	
<b>Alternative theoretical method:</b> Is GZ positive at heel angle defined above?	YES / NO?			7.5.5
<b>Design Category given:</b>		<b>FAIL</b>		

ISO 12217-3 CALCULATION WORKSHEET No. 11			WIND STIFFNESS TEST		
<b>NOT NEEDED</b>					
<b>METHOD:</b>					
Item	Symbol	Units	Unreefed	Reefed	Ref.
Boat prepared and weight positioned as 6.6.2	YES / NO?				7.6.2
Final tension in pull-down line	$T$	kg			7.6.4
Perpendicular lever between pull-down and mooring lines	$h$	m			7.6.4 figure 8
Final angle of heel observed	$\phi_T$	degrees			7.6.4
Beam of hull	$B_H$	m	0,00		ISO8666
Actual profile projected area of sails	$A'_S$	m <sup>2</sup>			3.4.9
Upright lever from centre of sail area to underwater profile	$h_{CE+h_{LP}}$	m			7.6.5 figure 9
Calculated wind speed = $\sqrt{((13hT+390B_H)/(A'_S(h_{CE}+h_{LP})(\cos(\phi_T)^{1.3})))}$	$v_W$	m/s	#DIV/0!	#DIV/0!	7.6.5
<b>Design Category given</b> Category C if $v_W \geq 11$ m/s, Category D if $v_W \geq 6$ m/s			NOT NEEDED	NOT NEEDED	7.6.7
<b>NB: Warning labels must be affixed to boat if Category is based on reefed sail plan.</b>					

**Alternative theoretical method:**

Item	Symbol	Units	Unreefed	Reefed	Ref.
Righting moment curve increased by one crew to windward	YES / NO?				7.6.6
Option (from Worksheet 3) being used			NOT NEEDED - BOAT IS NON-SAIL		Table 6
Design Category intended			0		
Relevant calculation wind speed	$v_W$	m/s	6	6	7.6.7
Actual profile projected area of sails	$A'_S$	m <sup>2</sup>			7.6.5
Upright lever from centre of sail area to underwater profile	$h_{CE+h_{LP}}$	m			7.6.5 Figure 9
Calculate: $0,75 v_W^2 A'_S (h_{CE} + h_{LP})$	$M_{W0}$	Nm			7.6.6
From righting moment curve augmented by 294 $B_H \cos \phi$ and wind heeling curve [ $= M_{W0} (\cos \phi)^{1.3}$ ] resulting angle of heel =	$\phi$	degrees			7.6.6
Is $\phi <$ that at which boat begins to fill with water, and $< 45^\circ$ ? YES / NO?					7.6.3
If YES, <b>Design Category given:</b>			NOT NEEDED	NOT NEEDED	
<b>NB: Warning labels must be affixed to boat if Category is based on reefed sail plan.</b>					

ISO 12217-3 CALCULATION WORKSHEET No. 12				SUMMARY	
Design Description:			Date:	18.9.2014	
<b>COMPLETE THE TABLE</b>					
Design Category intended:			<b>0</b>	Crew Limit:	0
Sheet	Item	Symbol	Units	Value	
1	Length of hull: (as ISO 8666)	$L_H$	m	0,00	
	Mass:				
	Maximum total load	$m_{MTL}$	kg	0,00	
	Light craft condition mass	$m_{LCC}$	kg	100,00	
	Loaded displacement mass = $m_{LCC} + m_{MTL}$	$m_{LDC}$	kg	100,00	
1	Is boat sail or non-sail?	SAIL / NON-SAIL			NON-SAIL
<b>NB: If boat is sailing but is also equipped for use as a non-sailing boat, both must be examined</b>					
2 and 3	Option selected:				<b>0</b>
4	Downflooding openings:	Units	Required	Actual	Pass/Fail
are all requirements met?					
<b>FAIL</b>					
4 or 5	Downflooding height:	Worksheet employed for basic height			
	basic requirement	m	$\geq \#DIV/0!$	0,5	<b>#DIV/0!</b>
	reduced height for small openings ( <i>sheet 4 only</i> )	m	<b>&gt; ERR</b>	0	<b>FAIL</b>
	reduced height at outboard ( <i>options 1 &amp; 3 only</i> )	m	<b>NOT NEEDED</b>	0	<b>PASS</b>
increased height at bow ( <i>options 1, 3, 5, 6 only</i> )	m	<b>NOT NEEDED</b>	0	<b>PASS</b>	
4	Outboard boats when starting:	Are all requirements met?		YES / NO?	<b>PASS</b>
6	Offset load test:				
	Residual freeboard	mm	$\geq \#N/A$	0	<b>#N/A</b>
	option 2: maximum heel angle	degrees	<b>NOT NEEDED</b>	0	<b>PASS</b>
7	Flotation test: ( <i>options 1, 6, 8 and 9 only</i> ) all preparations completed?	YES / NO?			<b>PASS</b>
	For Level Flotation assess items marked <sup>a</sup> , for Basis Flotation those marked <sup>b</sup>				
	Swamped stability <sup>a</sup> :	5 min after swamping, does boat heel less than 45°?		<b>NOT NEEDED</b>	<b>PASS</b>
	Load Test <sup>b</sup> :	5 min after swamping, does boat float level with 2/3 showing?		<b>NOT NEEDED</b>	<b>PASS</b>
	One Person Test <sup>a</sup> :	5 min after swamping, does boat float so that it can be bailed?		<b>NOT NEEDED</b>	<b>PASS</b>
	Flotation elements <sup>b</sup> :	do all elements comply with all the requirements?		<b>NOT NEEDED</b>	<b>PASS</b>
8	Basic Flotation by calculation:	value of $m_{TEST} / V_B$	< 930	<b>NOT NEEDED</b>	<b>PASS</b>
9	Capsize Recovery Test: ( <i>options 3 + 7 only</i> )	are all requirements met?			<b>PASS</b>
		Design Category recommended by the builder		<b>C</b>	//////////
10	Knockdown Recovery Test: ( <i>options 8 &amp; 10 only</i> )	PASS / FAIL?			<b>PASS</b>
		Method used = experimental or theoretical?		EXPERIMENTAL	
11	Wind Stiffness Test: ( <i>options 9 &amp; 11 only</i> )	CATEGORY GIVEN	<b>NOT NEEDED</b>	<b>FAIL</b>	
11	Was reefed sail area used? (i.e.: are warning labels required?)	REEFED - LABELS			//////////
<b>NB: Boat must pass all requirements applicable to option to be given intended Design Category.</b>					
Assessed by:				Design Category given:	<b>###</b>