

# Projektiranje i upravljanje pneumatskog sustava za ispitivanje dinamičke izdržljivosti materijala

---

**Bača, Marko Miroslav**

**Undergraduate thesis / Završni rad**

**2021**

*Degree Grantor / Ustanova koja je dodijelila akademski / stručni stupanj:* **University of Zagreb, Faculty of Mechanical Engineering and Naval Architecture / Sveučilište u Zagrebu, Fakultet strojarstva i brodogradnje**

*Permanent link / Trajna poveznica:* <https://urn.nsk.hr/urn:nbn:hr:235:292785>

*Rights / Prava:* [In copyright](#)/[Zaštićeno autorskim pravom.](#)

*Download date / Datum preuzimanja:* **2024-07-16**

*Repository / Repozitorij:*

[Repository of Faculty of Mechanical Engineering and Naval Architecture University of Zagreb](#)



SVEUČILIŠTE U ZAGREBU  
FAKULTET STROJARSTVA I BRODOGRADNJE

# ZAVRŠNI RAD

**Marko Miroslav Bača**

Zagreb, 2021.

SVEUČILIŠTE U ZAGREBU  
FAKULTET STROJARSTVA I BRODOGRADNJE

# ZAVRŠNI RAD

Mentor:

Prof. dr. sc. Željko Šitum

Student:

Marko Miroslav Bača

Zagreb, 2021.

Izjavljujem da sam ovaj rad izradio samostalno koristeći znanja stečena tijekom studija i navedenu literaturu.

Zahvaljujem se svome mentoru prof. dr. sc. Željku Šitumu na ukazanoj pomoći, uputama i savjetima tokom izrade završnog rada.

Zahvaljujem se asistentu Juraju Beniću mag. ing. na velikoj podršci s mnogobrojnim savjetima tijekom izrade ovoga rada.

Hvala prof. dr. sc. Željku Alaru na pruženoj prilici i pomoći prilikom realizacije eksperimentalnog postava.

Na kraju bih se zahvalio svojoj majci na podršci i povjerenju ukazanom tijekom studija.

Marko Miroslav Bača



SVEUČILIŠTE U ZAGREBU  
FAKULTET STROJARSTVA I BRODOGRADNJE



Središnje povjerenstvo za završne i diplomske ispite  
Povjerenstvo za završne ispite studija strojarstva za smjerove:  
proizvodno inženjerstvo, računalno inženjerstvo, industrijsko inženjerstvo i menadžment, inženjerstvo  
materijala i mehatronika i robotika

Sveučilište u Zagrebu Fakultet strojarstva i brodogradnje	
Datum	Prilog
Klasa: 602 - 04 / 21 - 6 / 1	
Ur.broj: 15 - 1703 - 21 -	

## ZAVRŠNI ZADATAK

Student: **MARKO MIROSLAV BAČA** Mat. br.: 0035213853

Naslov rada na hrvatskom jeziku: **PROJEKTIRANJE I UPRAVLJANJE PNEUMATSKOG SUSTAVA ZA ISPITIVANJE DINAMIČKE IZDRŽLJIVOSTI MATERIJALA**

Naslov rada na engleskom jeziku: **DESIGN AND CONTROL OF A PNEUMATIC SYSTEM FOR TESTING DYNAMIC STRENGTH OF MATERIALS**

Opis zadatka:

Usljed dugotrajnih periodičnih promjenljivih opterećenja (naprezanja) dolazi do tzv. umora materijala, čije su posljedice puknuće materijala pri znatno manjim naprezanjima od maksimalne vlačne čvrstoće. Trajnu dinamičku čvrstoću, tj. dinamičku izdržljivost moguće je analizirati na ispitnim sustavima (umaralicama) koji omogućuju ispitivanje stvarnim opterećenjima mehaničkih komponenti kakvi se očekuju tijekom njihove eksploatacije. Kod sustava kod kojih je potrebno ostvariti manje sile za ispitivanje dinamičke izdržljivosti mogu se koristiti umaralice s pneumatskim aktuatorom. U suvremenim rješenjima pneumatskih sustava za ispitivanje materijala traže se mogućnosti programiranog upravljanja gibanjem i/ili silom aktuatora, kao i mogućnost brze prilagodbe upravljačkih algoritama novim zahtjevima u procesu ispitivanja materijala. U usporedbi s hidrauličkim rješenjima koja se koriste za ostvarenje velikih sila, pneumatske umaralice su ekološki prihvatljivije i jednostavnije su konstrukcijske izvedbe.

U radu je potrebno:

- projektirati ispitni sustav za ostvarenje dinamičkog opterećenja materijala, koji koristi dvoradni pneumatski cilindar upravljan proporcionalnim tlačnim regulatorima za ostvarenje potrebne sile,
- izraditi eksperimentalni postav pneumatskog ispitnog uređaja koji koristi upravljački uređaj Controllino za ostvarenje željenog iznosa i oblika sile,
- dati tehnički opis korištenih komponenti mehaničkog, mjernog i upravljačkog dijela sustava,
- razvijene upravljačke algoritme ispitati na eksperimentalnom postavu i komentirati dobivene rezultate.

Zadatak zadan:  
30. studenoga 2020.

Datum predaje rada:  
**1. rok:** 18. veljače 2021.  
**2. rok (izvanredni):** 5. srpnja 2021.  
**3. rok:** 23. rujna 2021.

Predviđeni datumi obrane:  
**1. rok:** 22.2. – 26.2.2021.  
**2. rok (izvanredni):** 9.7.2021.  
**3. rok:** 27.9. – 1.10.2021.

Zadatak zadao:

Prof. dr. sc. Željko Šitum

Predsjednik Povjerenstva:

Prof. dr. sc. Branko Bauer

## SADRŽAJ

SADRŽAJ .....	I
POPIS SLIKA .....	II
POPIS TEHNIČKE DOKUMENTACIJE .....	III
POPIS OZNAKA.....	IV
SAŽETAK.....	V
SUMMARY .....	VI
1. Uvod .....	1
2. Mehanička svojstva materijala .....	2
2.1. Umor materijala .....	2
2.2. Ispitivanje umora materijala.....	3
2.3. Osnovne karakteristike pneumatskog sustava.....	5
3. Simulacijski model sustava.....	6
3.1. Komponente sustava .....	6
3.2. Simulacijski program .....	7
3.2.1. Model kompresora i ulaska u sustav .....	8
3.2.2. Proporcionalni tlačni regulator.....	9
3.2.3. Model dvoradnog cilindra.....	11
3.3. Simulacijski model umaralice .....	12
4. Projektiranje sustava.....	15
4.1. Projektiranje nosive konstrukcije sustava .....	15
4.2. Projektiranje pneumatskog dijela sustava .....	17
4.2.1. Pneumatski cilindar.....	17
4.2.2. Proporcionalni tlačni regulator.....	19
4.2.3. Pripremna grupa.....	20
4.2.4. Ostale pneumatske komponente .....	21
4.2.5. Pneumatska shema sustava .....	22
4.2.6. 3D model projektiranog pneumatskog sustava .....	23
4.3. Projektiranje električnog dijela sustava .....	24
4.3.1. Upravljačka jedinica .....	24
4.3.2. Karakteristike odabrane upravljačke jedinice .....	25
4.3.3. Senzor sile .....	26
4.3.4. Mjerno pojačalo .....	27
4.3.5. HMI (eng. Human Machine Interface) .....	28
4.3.6. Ostale elektroničke komponente.....	28
4.4. 3D model projektiranog sustava .....	29
5. Izrada eksperimentalnog postava.....	30
6. Zaključak .....	31

## POPIS SLIKA

Slika 1.	Prikaz prijelomne površine [2] .....	2
Slika 2.	Tipovi promjenljivo naprezanja [2].....	3
Slika 3.	Različiti oblici promjenljivog naprezanja [2].....	4
Slika 4.	Wöhlerov dijagram [2] .....	5
Slika 5.	Polazna simulacijska shema .....	6
Slika 6.	Konačna simulacijska shema.....	7
Slika 7.	Pojednostavljeni model kompresora i pripreme grupe.....	8
Slika 8.	Svojstva zraka korištena u simulaciji .....	9
Slika 9.	Model proporcionalnog tlačnog regulatora .....	10
Slika 10.	Odzivi modela proporcionalnog tlačnog ventila .....	11
Slika 11.	Model dvoradnog cilindra .....	12
Slika 12.	Model sustava umaralice .....	13
Slika 13.	Odziv sustava na odskočnu funkciju .....	13
Slika 14.	Odziv sustava na zadane pobudne funkcije.....	14
Slika 16.	Aluminijski profil [6] .....	15
Slika 15.	Kutni spojni element [6].....	15
Slika 17.	3D model nosive konstrukcije sustava .....	16
Slika 18.	Teorijska sila cilindra [7] .....	17
Slika 19.	Područje rada modela cilindra [7] .....	18
Slika 20.	Pneumatski cilindar .....	19
Slika 21.	ITV- proporcionalni tlačni regulator [7] .....	19
Slika 22.	Karakteristika ITV 205X serije [7] .....	20
Slika 23.	3D model pripreme grupe [7].....	21
Slika 24.	Prigušno nepovratni ventili [7].....	21
Slika 25.	Shema pneumatskog kruga.....	22
Slika 26.	Projektirani 3D model s pneumatskim sustavom .....	23
Slika 27.	Controllino Maxi Power Automation [8] .....	25
Slika 28.	HBM Z30A [9].....	26
Slika 29.	Shema spoja senzora [9].....	26
Slika 30.	Mjerno pojačalo BM 40 [9].....	27
Slika 31.	Blok dijagram senzora [9] .....	27
Slika 32.	HMI 4DSYSTEMS SK90-DT [10].....	28
Slika 33.	3D model projektiranog sustava pogled 1.....	29
Slika 34.	3D model projektiranog sustava pogled 2.....	29
Slika 35.	Eksperimentalni postav sustava.....	30

## **POPIS TEHNIČKE DOKUMENTACIJE**

<b>BROJ CRTEŽA</b>	<b>Naziv iz sastavnice</b>
01-01	Pneumatski sustav za ispitivanje
01-02	Električne sheme spajanja
01-03	Pneumatska shema sustava



---

**POPIS OZNAKA**

<b>Oznaka</b>	<b>Jedinica</b>	<b>Opis</b>
f	Hz	Frekvencija
$R_d$	$N/mm^2$	Dinamička izdržljivost
$p_a$	Pa	Atmosferski tlak
T	K	Temperatura okoline
F	N	Sila na klip cilindra
p	Pa	Tlak u komorama cilindra
A	$mm^2$	Površina klipa cilindra
$d_i$	mm	Minimalni promjer klipa cilindra
d	mm	Promjer klipa cilindra

## **SAŽETAK**

Dinamička izdržljivost materijala vrlo je važno mehaničko svojstvo materijala koji se koristi u proračunima proizvoda i poluproizvoda. Budući da nije moguće teorijski utvrditi njegove vrijednosti, provode se eksperimentalna ispitivanja na umaralicama. Umaralice su uređaji koji zadani ispitni uzorak opterećuju prema referentnim signalima, ciklički i dugotrajno. Pneumatski sustav za ispitivanje dinamičke izdržljivosti materijala opisan je simulacijskim modelom, zatim je izvršeno projektiranje konstrukcije, pneumatskog i električnog dijela sustava. Izrađeni su 3D modeli svake faze projektiranja, te kao zadnja faza konstruiran je eksperimentalni postav uređaja.

Ključne riječi: dinamička izdržljivost, umor materijala, pneumatski sustav za ispitivanje dinamičke izdržljivosti materijala, pneumatski cilindar, tlačni regulator, senzor sile

## **SUMMARY**

Dynamic durability of a material is a very important mechanical property of a material used in the product and semi-finished product calculations. Since it is not possible to determine its values theoretically, experimental tests are performed on fatigue bars. Fatigue devices are devices that load a given test sample according to reference signals, cyclically and for a long time. The pneumatic system for testing the dynamic durability of materials was described by a simulation model, then the design of the structure, pneumatic and electrical part of the system was performed. 3D models of each design phase were made, and as the last phase, an experimental setup of the device was constructed.

Key words: dynamic durability, fatigue, pneumatic system for testing the fatigue strength of materials, pneumatic cylinder, pressure regulator, force sensor

## 1. Uvod

Težnja svih inženjera koja seže još iz daleke povijesti je stvaranje laganijih konstrukcija i proizvoda, kako bi se ostvarila ušteda materijala i ušteda energije ukoliko govorimo o gibajućim elementima zbog dodatne mase koju je potrebno ubrzati potom i kočiti što čini gubitak korisne energije. Upravo ta težnja za smanjivanjem materijala potrebnog za izradu konstrukcije dovela je do značajnog napretka u načinima konstruiranja. Međutim, što nam znači ušteda materijala ukoliko proizvod prije kraja svog životnog ciklusa doživi lom te postane ne upotrebljiv. Tada sav trud oko uštede materijala i energije propada te je potrebno izraditi novi element kako bi se zadovoljio traženi životni vijek nekog proizvoda. Za sprečavanje takvih pojava ulažu se veliki naponi ispitivanja mehaničkih svojstava materijala, dijelom statičkih, a dijelom dinamičkih ispitivanja. Takvim ispitivanjima dobivamo potrebne parametre i koeficijente za proračune konstrukcije i proizvoda kako bi načinili komponente što manjih dimenzija uz ostvarivanje zahtjeva za traženi životni vijek.

Ispitivanje umaranja jedan je od osnovnih dinamičkih ispitivanja mehaničkih svojstava materijala. Ispitivanje se provodi na ispitnim uređajima umaralicama. Umaralice su najčešće pogonjene hidraulički ili servohidraulički kako bi se na jednom uređaju mogao izvršiti veći broj ispitivanja. Takvi uređaji najčešće ostvaruju vrlo velike sile (reda veličine 100 000 N), a same dimenzije uređaja su vrlo velike. U današnje vrijeme, kada se sve više proizvoda izrađuje od polimernih ili metalnih limova nije potrebno koristiti uređaje koji imaju mogućnost ostvarenja visokih iznosa sile. Upravo na tome počiva ovaj rad, u kojem je cilj izrada pneumatskog sustava umaralice. Pneumatski sustavi mogu ostvariti potrebne sile, zbog upotrebe stlačenog zraka kao fluida, nema potrebe za povratnim vodovima i velikim spremnicima fluida te vrlo skupim i kompleksnim uređajima za regulaciju, što su glavni nedostaci hidraulike. Upravo korištenje pneumatike omogućava ostvarivanje tražene sile uz slijeđenje zadane dinamike, uz to cijeli sustav bit će značajno manjih dimenzija pogodan za stolnu i mobilnu primjenu u laboratorijima za ispitivanje dinamičkih svojstava materijala.

## 2. Mehanička svojstva materijala

Mehanička svojstva materijala imaju poseban značaj budući da se na njihovoj osnovi radi dimenzijski proračun konstrukcija [1]. Kako relacija „strukturno stanje-mehanička svojstva“ vrijedi isključivo za idealne tvari, u realnim tvarima su prisutne strukturne nepravilnosti koje nije moguće egzaktno uočiti i u konačnici uključiti u proračun. Upravo zbog toga mehanička svojstva realnih materijala moguće je ispitati isključivo eksperimentalno. Osnovna podjela mehaničkih ispitivanja je shodno promjeni naprezanja na statičko i dinamičko ispitivanje. Prilikom statičkog ispitivanja iznos naprezanja tijekom ispitivanja je konstantan ili je promjena naprezanja mala, dok se kod dinamičkog ispitivanja promjena naprezanja tijekom ispitivanja ciklički mijenja i ta promjena je uobičajeno periodičkog karaktera.

### 2.1. Umor materijala

Umor materijala je pojava kod koje dolazi do loma uslijed naprezanja nižeg od granice razvlačenja materijala, postupnim razaranjem materijala zbog dugotrajnog dinamičkog naprezanja. Svrha ispitivanja dinamičke izdržljivosti materijala je određivanje ponašanja materijala uslijed djelovanja dugotrajnog promjenjivog opterećenja. Svojstvo otpornosti pojave umora materijala nazivamo dinamička izdržljivost. Podaci dobiveni eksperimentalno izrazito su važni u proračunima konstrukcija koje su opterećene dinamičkim naprezanjem. Prilikom dimenzioniranja dijelova konstrukcije ne koriste se podaci dobiveni statičkim ispitivanjem, jer oni nisu dovoljno točni ili mogu biti i sasvim netočni [1].

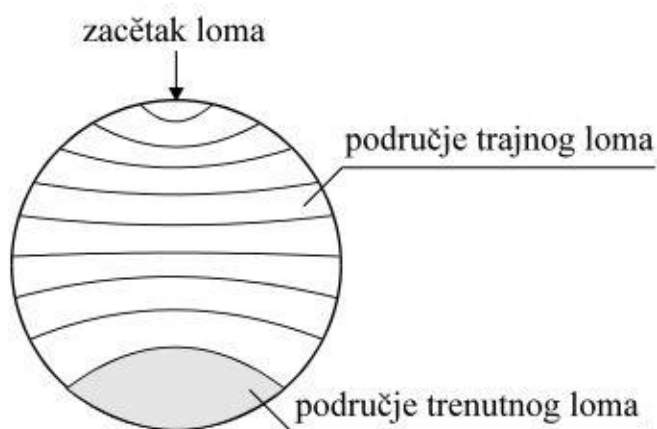

Slika 1. Prikaz prijelomne površine [2]

Na slici [Slika 1.] vidljiv je shematski prikaz karakteristične prijelomne površine prilikom umora materijala. Početak loma počiva na nesavršenosti određenog poluproizvoda odnosno proizvoda, a te nesavršenosti mogu biti konstrukcijskog, tehnološkog ili eksploatacijskog porijekla. Potom slijedi područje trajnog loma kojeg karakteriziraju brazde koje podsjećaju na godove drveta, taj dio nastao je tijekom duljeg vremena. Zadnja faza loma je područje trenutnog loma. To područje je hrapavo i zrnato, a nastaje u trenutku kada je zadano naprezanje zbog smanjene nosive površine prekoračilo vrijednost vlačne čvrstoće materijala [1].

## 2.2. Ispitivanje umora materijala

Podjela ispitivanja sukladno frekvenciji promjene opterećenja [1]:

- Niskofrekventno  $f < 5$  Hz
- Srednjefrekventno  $5 \text{ Hz} < f < 30$  Hz
- Visokofrekventno  $f > 30$  Hz

Ovisno o smjeru naprezanja osnovna podjela je na istosmjerno promjenljivo naprezanje koje može biti u području tlaka ili vlaka. Zatim izmjenično promjenljivo naprezanje koje u jednom dijelu svoga ciklusa prolazi kroz apscisu te mijenja a svoj smjer, što je vidljivo na slici [Slika 2.].

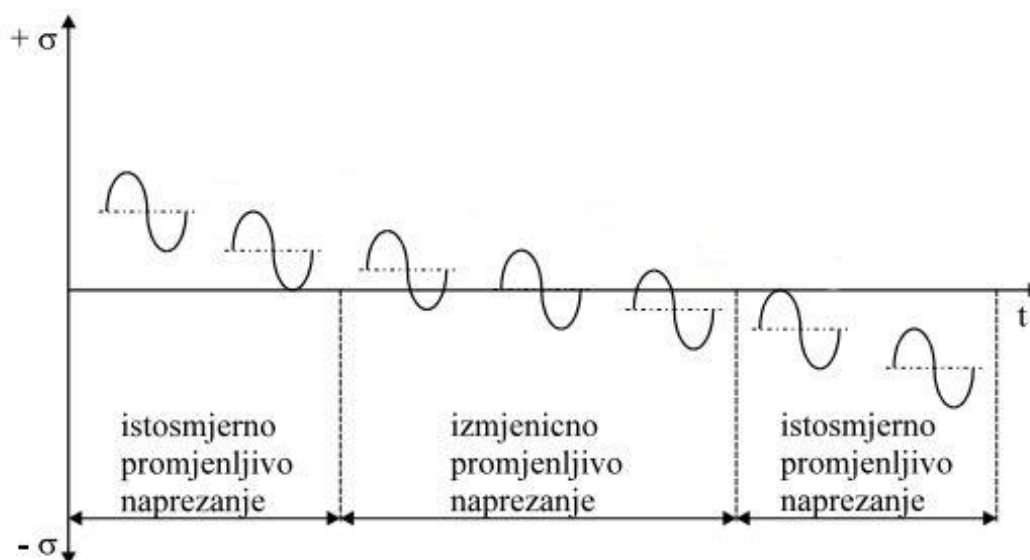

Slika 2. Tipovi promjenljivo naprezanja [2]

Pri ispitivanju na umaralicama nastoje se simulirati uvjeti što sličniji uvjetima u eksploataciji. Moderni ispitni sustavi omogućuju različite oblike dinamičkog naprežanja, što je vidljivo na slici [Slika 3].

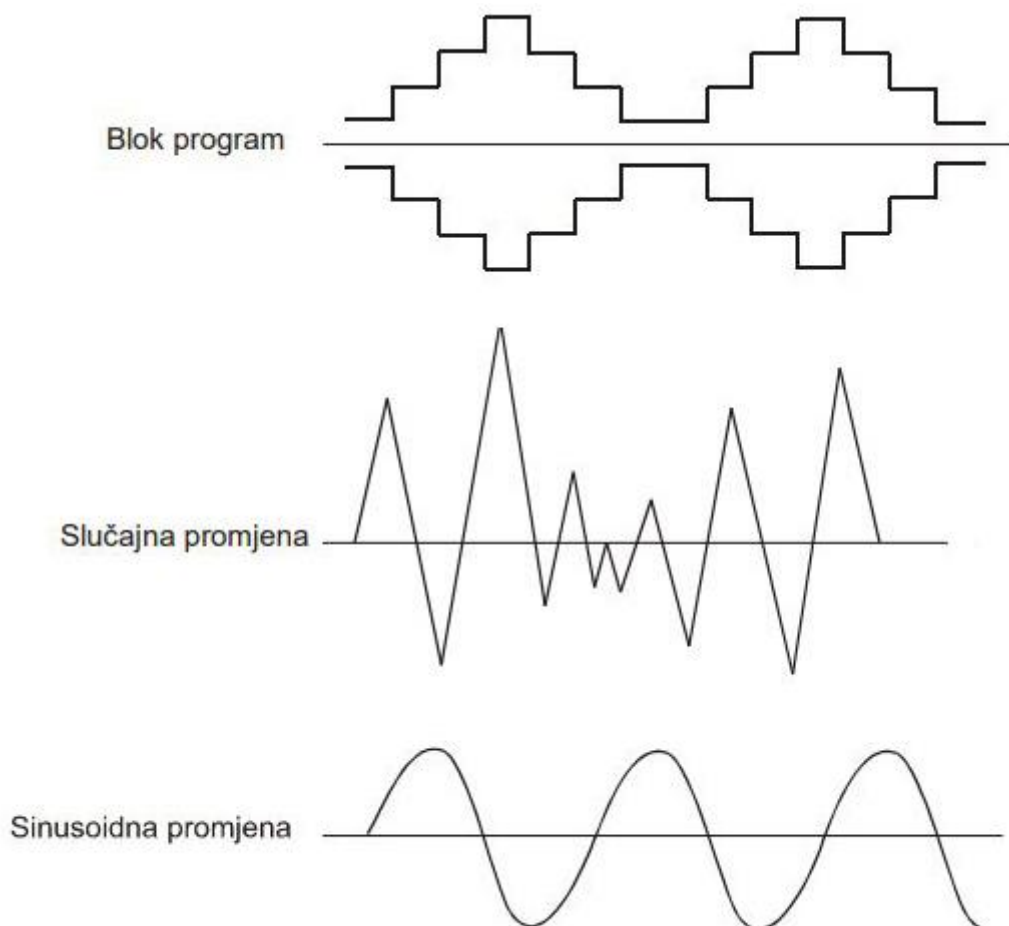

**Slika 3. Različiti oblici promjenljivog naprežanja [2]**

Za određivanje dinamičke izdržljivosti provodi se Wöhlerov pokus, izabire se jedan od tipova promjenljivog naprežanja te se za odabrani raspon naprežanja određenih amplitudom ili gornjim naprežanjem istovremeno ispituje 6 do 10 epruveta koje moraju biti izrađene u skladu s normom. Rezultate ispitivanja prikazujemo Wöhlerovim dijagramom [Slika 4.] u kojem označavamo vrijednosti naprežanja i broj ciklusa koje su epruvete izdržale prije puknuća.

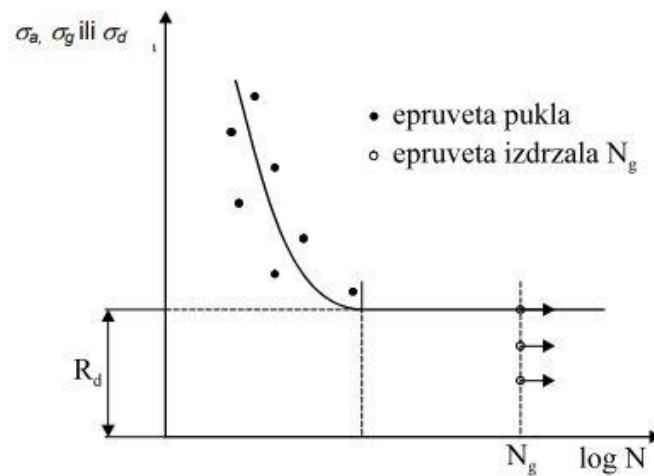

Slika 4. Wöhlerov dijagram [2]

Dinamička izdržljivost  $R_d$  označava najveće dinamičko naprežanje koje epruvete mogu izdržati bez pojave loma nakon praktički beskonačnog broja ciklusa. Beskonačni broj ciklusa predstavlja granični broj ciklusa koji su različiti za različite tipove materijala [1] npr. za čelike  $N_g = 10^7$  titraja.

### 2.3. Osnovne karakteristike pneumatskog sustava

Iz osnovnog uvoda o mehaničkim svojstvima materijala i načinima ispitivanja prikazanim u ovom poglavlju, postavljamo osnovne zahtjeve na sustav pneumatske umaralice koji moraju biti zadovoljeni kako bi projektirani sustav mogao provoditi ispitivanja materijala.

Karakteristike sustava su:

- Precizna regulacija sile u rasponu od 0 do 10 000 N u zatvorenom regulacijskom krugu putem mjernog senzora i mjernog pojačala visoke razine točnosti
- Rad u uvjetima istosmjernog promjenjivog i izmjeničnog promjenjivog naprežanja
- Praćenje različitih standardnih referentnih signala te stohastičkih signala snimljenih iz eksploatacijskih uvjeta
- Dugi rad za postizanje traženog broja ciklusa
- Konstrukcija uređaja mora omogućavati spajanje različitih prihvatnih uređaja, te imati mogućnost regulacije visine ovisno o zadanom ispitnom uzorku.



### 3. Simulacijski model sustava

#### 3.1. Komponente sustava

Kreiranjem simulacijskog modela pneumatske umaralice u odgovarajućem računalnom programu, istražujemo osnovne karakteristike i ponašanje sustava kao cjeline, regulatora i svih ostalih komponenti, koje su potrebne prije ugradnje komponenti na eksperimentalnom postavu. Iz karakteristika koje sustav mora ispunjavati, zaključujemo da je za ispitivanje nisko elastičnih materijala ili relativno tankih polimernih materijala, potreban cilindar s mogućnošću samostalnog povratka klipa. Kako u tim slučajevima sam ispitni uzorak unosi malen iznos energije te uz gubitke unutar samih ispitnih uzoraka sila reakcije prilikom popuštanja opterećenja nije dovoljna za povratni pomak klipa cilindra. Tim zahtjevima odgovara dvoradni cilindar te jednoradni cilindar s oprugom. Iz dinamičkih zahtjeva vidljivo je da ispitni sustav mora biti u mogućnosti pratiti širok spektar referentnih opterećenja koja se kontinuirano mogu opisati jednostavnim matematičkim funkcijama, kao i ona koja su snimljena mjernim instrumentima iz eksploatacijskih uvjeta, koja su u većini slučajeva stohastičke prirode. Prilikom rada s opružnim cilindrima ovisimo o karakteristikci ugrađene opruge koja je zadovoljavajuća za kontinuirane promjene poput slijeđenja nagibnih ili sporih trigonometrijskih funkcija. Prilikom slijeđenja referenci s naglim skokovitim promjenama, dinamika takvog cilindra bila bi suviše troma te bi postojala kašnjenja i odstupanja od zadane reference. Zbog ranije navedenih razloga jedini preostali izbor je dvoradni cilindar.

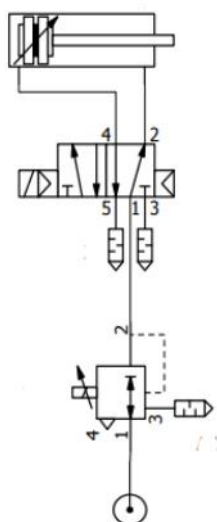

Slika 5. Polazna simulacijska shema

Na gornjoj shemi [Slika 5.] prikazana je polazna pneumatska shema. Za regulaciju tlaka odabran je proporcionalni tlačni regulator zbog svojih pogodnih karakteristika i direktne ovisnosti tlaka u komori cilindra sa ostvarenom silom. Razvodni ventil 5/2 ima ulogu prespajanja tlačnog voda s jedne komore cilindra na drugu ovisno o zadanoj referenci. Takva shema pogodna je za praćenje reference s blagim promjenama. Budući da je potrebno osigurati praćenje naglih i skokovitih referenci umjesto razvodnog ventila dodan je drugi proporcionalni ventil. Sada je moguće kontinuirano upravljanje tlaka u obje komore cilindra.

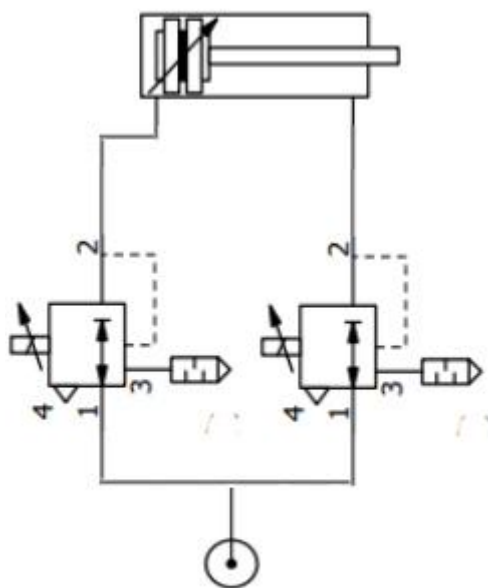

Slika 6. Konačna simulacijska shema

### 3.2. Simulacijski program

Za simuliranje sustava odabran je program Matlab s paketom Simscape. Matlab kao simulacijski alat dobro je poznat i raširen u inženjerskoj praksi, te kao takav često u kombinaciji sa Simulinkom prvi izbor u stvaranju simulacijskih modela. Simscape je paket koji je baziran na Simulinku s mogućnošću brzog stvaranja modela fizičkih sustava, povezivanje različitih fizičkih domena kao i integriranje sa Simulinom. Glavna karakteristika paketa je modeliranje i simuliranje sustava koji se sastoje od stvarnih komponenti. Blokovi odgovaraju stvarnim elementima te se spajaju fizičkim vezama koje prenose odgovarajuću fizikalnu veličinu. Na primjer spajanje dvoradnog cilindra izvršava se s dva voda koja dolaze sa razvodnog ventila koja prenose tlak i protok, kako i u stvarnosti. Također moguće je spajanje više fizičkih sustava

poput spajanja električnog motora na reduktor s trenjem i teretom koji okreće pneumatski kompresor koji puni jedan pneumatski spremnik. Prva je električna domena elektro motora, potom prelazimo u mehaničku domenu sila koje uzrokuju gibanje te one koje uzrokuju gubitke, dolaskom do pumpe prelazimo u pneumatski domenu, a kako cijeli sustav sadrži unutarnje gubitke kao takav čini termalnu domenu u kojoj je svaka komponenta povezana s njome. Iz prethodnog primjera vidljivo je kako bi matematički opis svih komponenti i njihovih pojava iziskivao složene matematičke izvode funkcija članova i izvode funkcija gubitaka te njihovo zapisivanje u obliku prijenosnih funkcija, koje bi na kraju rezultirale modelom u Simulinku. Korištenjem paketa Simscape matematički izvodni nisu potrebni, odmah se prelazi na kreiranje modela čime se ostvaruje značajna ušteda vremena, a simulacijski modeli su čitljiviji i veze su puno jasnije.

### 3.2.1. Model kompresora i ulaska u sustav

Pojednostavljenja koja uvodimo su zanemarivanje pada tlaka u vodovima te zanemarivanje dinamike pripreme grupe. Pad tlaka uslijed gubitaka u vodovima je zanemarivog iznosa u smislu pneumatskog kruga, dinamika pripreme grupe u kojoj spadaju uključni razvodnik, sigurnosni ventil i filtri je vrlo malog iznosa.

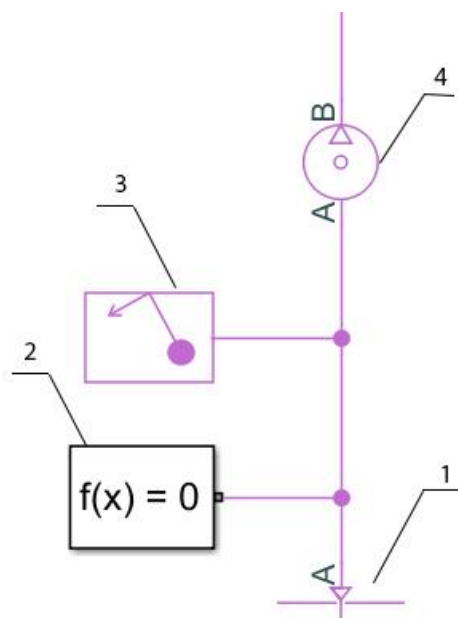

1. Spremnik beskonačnog volumena
2. Početni uvjeti rješavača (eng. *solver*)
3. Svojstva plina
4. Izvor tlaka

**Slika 7. Pojednostavljeni model kompresora i pripreme grupe**

Spremnik beskonačnog kapaciteta predstavlja model okolišnog zraka. Njegov tlak, kao i temperatura ostaju konstantni tijekom cijelog vremena procesa. Stanje atmosfere definirano je normalnim stanjem, ono je po dogovoru definirano tlakom  $p_a=101\,325\text{ Pa}$  i  $T=273,15\text{ K}$  [3]. Blok svojstva plina omogućava nam da učitamo zadane podatke iz biblioteka ili ovisno o zahtjevu definiramo vlastite.

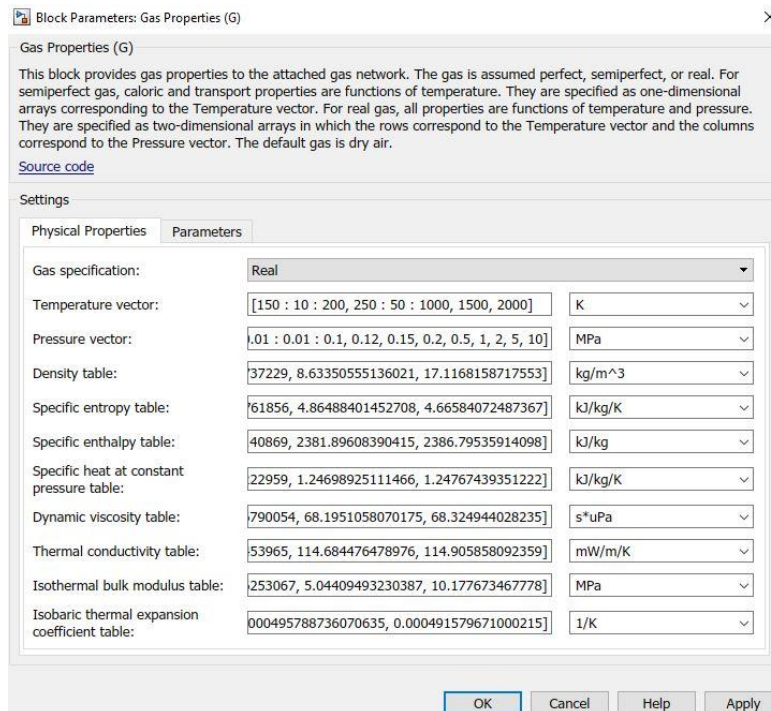

**Slika 8. Svojstva zraka korištena u simulaciji**

Izvor tlaka predstavlja idealni pretvornik mehaničke energije, s konstantnim održavanjem zadane razlike tlaka na ulasku i izlasku. Vrijednost taka na izlazu B iznosi 9 bar, taj tlak odgovara standardnim vrijednostima korištenim u industriji te većina kompresora može ostvariti tu vrijednost.

### 3.2.2. Proporcionalni tlačni regulator

Iako su proporcionalni tlačni regulatori vrlo česti elementi pneumatskih krugova biblioteka programskog paketa nema definiran njegov model. Ponašanje modela može se približno opisati spajanjem prigušnice s varijabilnim presjekom te razvodnika 3/2. On u jednom radnom položaju spaja tlačni vod i komoru cilindra. Regulacijom površine prigušnice moguće je ostvariti željene promjene tlaka. Drugi radni položaj spaja komoru cilindra i model atmosfere

koji služi kao ispust zraka iz sustava kada je potrebno ostvariti smanjenje tlaka prema zadanoj referenci. Regulacija sustava u zatvorenom krugu ostvaruje se preko povratne veze manometra spojenog sa zadanom referencom. Referenca je potpuno proizvoljna, a kako cijeli sustav ima mogućnost regulacije od atmosferskog do radnog tlaka kompresora, blok zasićenja ograničava vrijednost reference kako se na regulator ne bi postavljali zahtjevi koje on nije u stanju izvršiti.

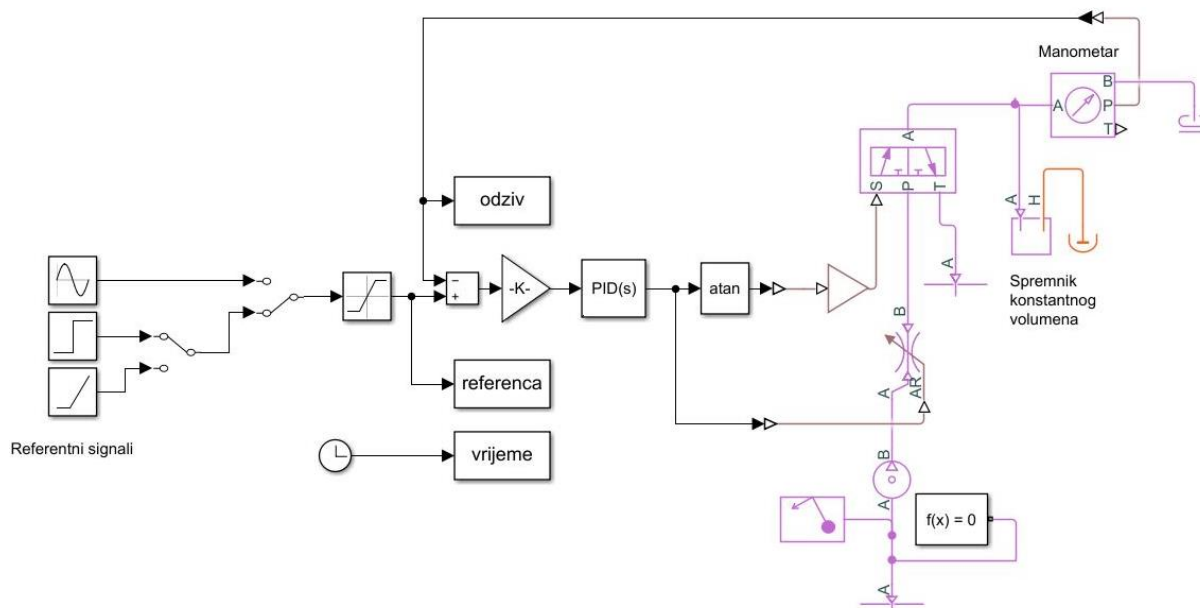

Slika 9. Model proporcionalnog tlačnog regulatora

U regulacijskom krugu koristi se PI regulator. Izlaz iz regulatora preko pretvornika signala dolazi do prigušnice koja mijenja poprečni presjek ovisno o iznosu upravljačkog signala. S istog izlaza signal dolazi do razvodnika 3/2 koji u slučaju zahtjeva za smanjenjem tlaka prebacuje radni položaj razvodnika. Kako bi se izbjegli diskontinuiteti koji se javljaju između dva stanja u tom dijelu kruga, signal se transformira pomoću inverzne trigonometrijske funkcije tangens.

Za testne reference sustava odabrane su standardne pobudne funkcije regulacijskih krugova. Odziv na odskočnu funkciju je vrlo brz te ima mali prebačaj do 1% u odnosu na referencu. Dodatne reference odabrane su radi provjere rada regulatora. Trigonometrijska funkcija sinus, izabrana je upravo zbog radnih karakteristika sustava koje su dugotrajne periodičke promjene opterećenja. Kod slijedenja odskočne i nagibne funkcije ne postoji trajno regulacijsko odstupanje, slijedenjem sinusne funkcije postoji blago odstupanje i kašnjenje koje je uobičajeno za takve uzbudne funkcije. Shodno tome model proporcionalnog tlačnog ventila, vjerno

simulira ponašanje stvarnog ventila te kao takav pogodan je za daljnju implementaciju u simulacijski model.

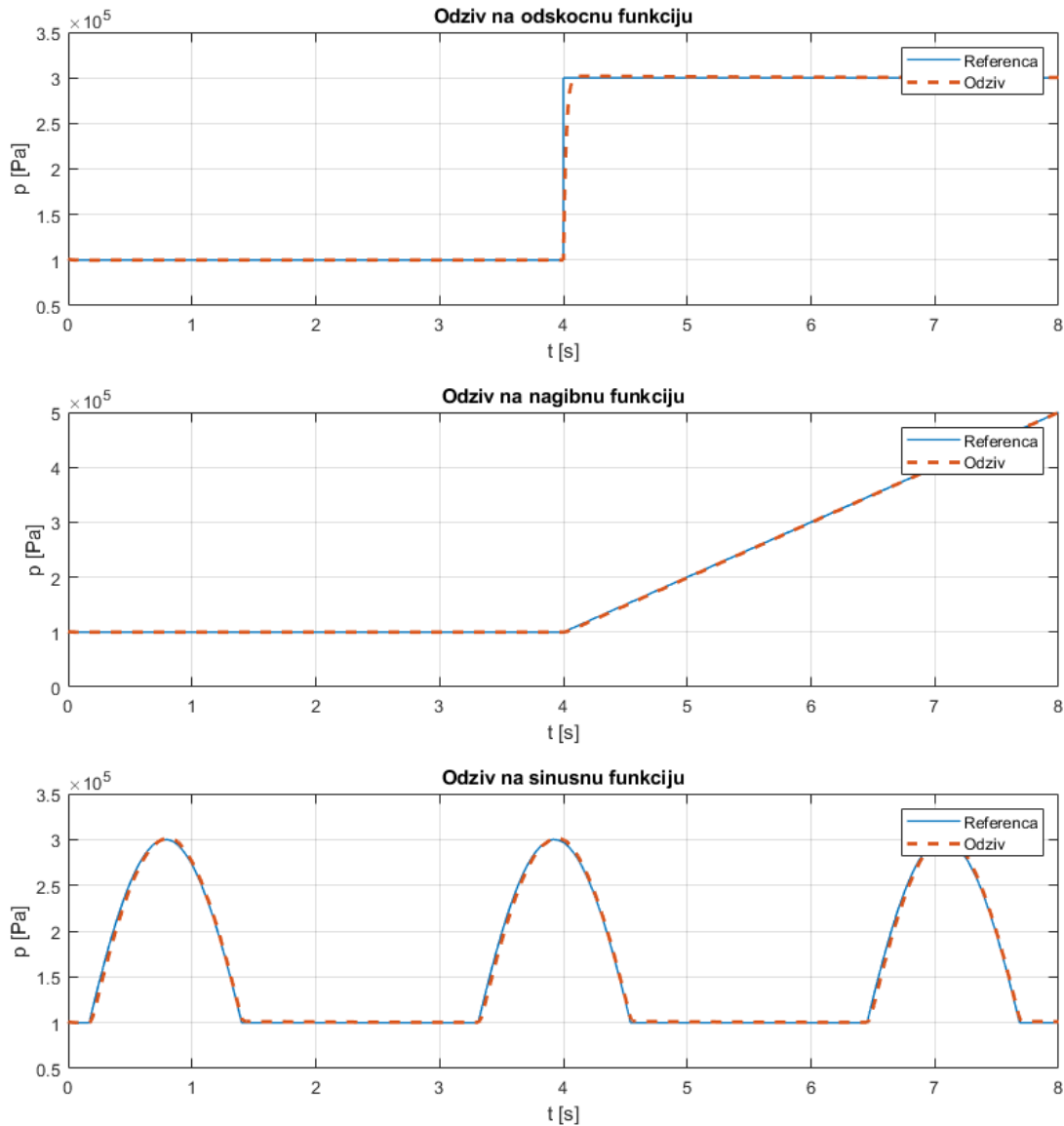

Slika 10. Odzivi modela proporcionalnog tlačnog ventila

### 3.2.3. Model dvoradnog cilindra

Model dvoradnog cilindra nije dostupan kao standardna komponenta unutar biblioteke, no unutar primjera programskog paketa izveden je kao model sastavljen od osnovnih komponenti, s mogućnošću učitavanja u biblioteku [4]. Dinamika i ponašanje izvedenog modela odgovara očekivanom ponašanju na različite pobude te je isti korišten u simulacijskom modelu. Za ispravno funkcioniranje modela potrebno je definirati veze u termalnoj domeni kao bi se mogle

analizirati pojave vezane uz prijelaz topline. Analiza i reguliranje termalnih pojava nije tema ovog rada, sve termalne veze nužne sustavu povezane su s blokom savršenog izolatora čime se onemogućuje protok topline kroz zadane blokove.

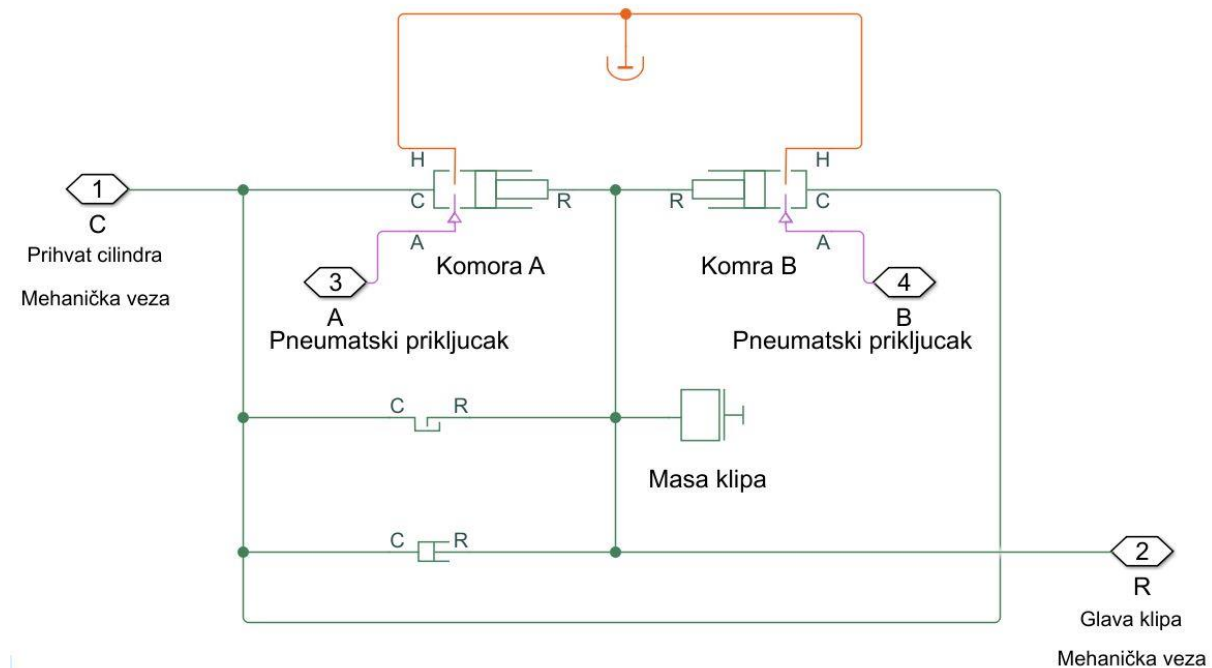

Slika 11. Model dvoradnog cilindra

### 3.3. Simulacijski model umaralice

Prema shemi [Slika 6.] izvodi se spajanje modela komponenti koji su ranije opisani u funkcionalnu cjelinu. Ispitni uzorak prikazan je dinamikom MDS sustava kako bi se simulirala elastična svojstva materijala i gubici unutar samog ispitnog uzorka. Na njegovu mehaničku vezu spaja se senzor sile. Putem povratne veze mjerenja sile zatvara se regulacijski krug. Regulator kruga je PID regulator, koji je zbog jednostavnosti, stabilnosti i robusnosti jedan od najčešćih izbora u regulacijskim krugovima. Odabirom odgovarajućih parametara dobivamo stabilan sustav koji vjerno slijedi zadanu referencu.

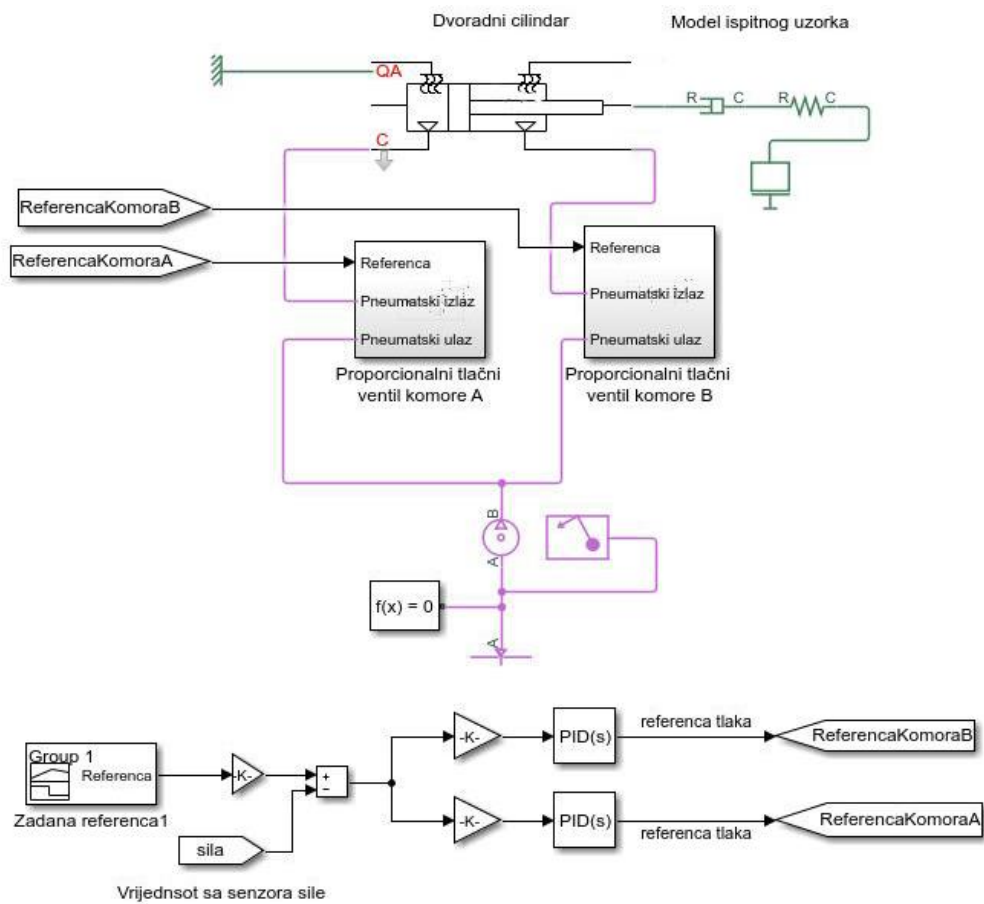

**Slika 12. Model sustava umaralice**

Sustav pobuđujemo standardnim pobudnim funkcijama koje su korištene i ranije prilikom ispitivanja rada proporcionalnog tlačnog regulatora. Iz slike [Slika 13.] vidljivo je da se sustav s odskočnom pobudnom funkcijom ponaša u skladu s očekivanjima. Prijelazna pojava sustava je vrlo kratka te brzo sustiže zadanu referencu, ne postoji trajno regulacijsko odstupanje.

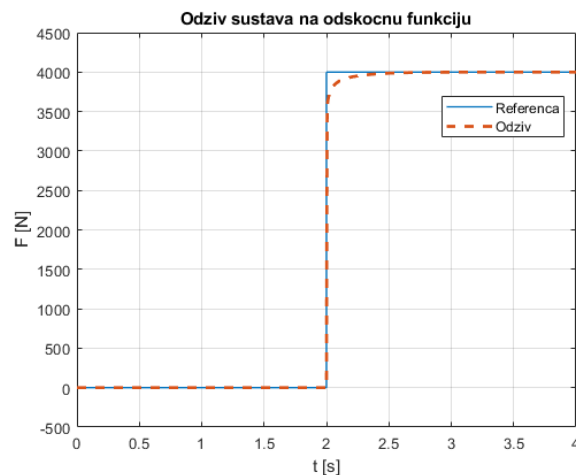

**Slika 13. Odziv sustava na odskočnu funkciju**



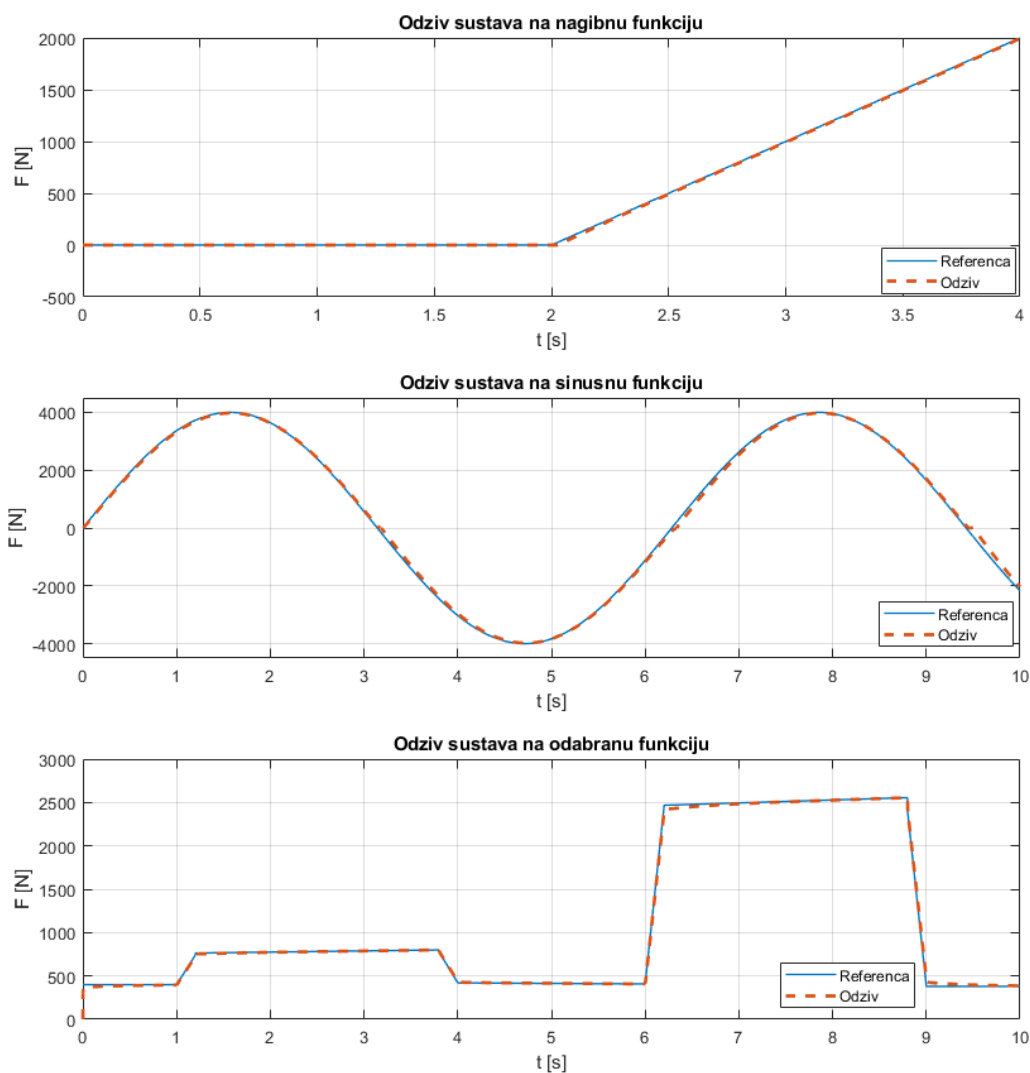

**Slika 14. Odziv sustava na zadane pobudne funkcije**

Iz simuliranja ostalih pobudnih funkcija [Slika 14.] vidljivo je da se model ponaša stabilno i vjerno slijedi zadane reference. Prijelazna pojava je vrlo kratka te ne postoji trajno regulacijsko odstupanje. Odabiranim parametrima regulatora postignut je odziv bez prebačaja na zadanu referencu, zbog same metodologije ispitivanja opisane u drugom poglavlju koja može biti vrlo blizu granice proporcionalnosti i granice elastičnosti materijala. Prelaskom preko tih vrijednosti ulazimo u plastično područje materijala, što ne zadovoljava osnovne karakteristike sustava umaralice.

## 4. Projektiranje sustava

### 4.1. Projektiranje nosive konstrukcije sustava

Model nosive konstrukcije sustava projektiran je od standardnih aluminijskih profila. Glavne prednosti takvih profila su visoka modularnost i veliki izbor profila, upravo zbog oblika koji omogućavaju spajanje više profila pod različitim kutovima koristeći kutne spojnik. Na profile se postavljaju različiti nosači, električne vodove potrebne za rad sastava moguće je voditi kroz profile čime ti vodovi postaju dodatno izolirani od radne okoline stroja, čime sustav postaje sigurnijim i vizualno atraktivniji. Upravo veliki broj različitih tipova profila omogućava izbor optimalnog rješenja, a konstrukcija profila može izdržati vrlo velike sile. Profili su ekološki vrlo prihvatljivi, ukoliko se uzme u obzir da se dijelovi konstrukcija trebaju obraditi tehnologijom obrade odvajanja čestica poput glodanja spojnih mjesta, blanjanja i dubljenja kanalicama za vodiče. Tim postupcima uklanja se velika količina materijala uz veliki utrošak energije. Kod standardnih profila jedini postupak koji imamo je rezanje na zadanu duljinu. Zbog ranije navedenih razloga takvi profili u današnje vrijeme zauzimaju značajno mjesto u raznim područjima poput prehrambena prerađivačke industrije, medicine i sličnih.

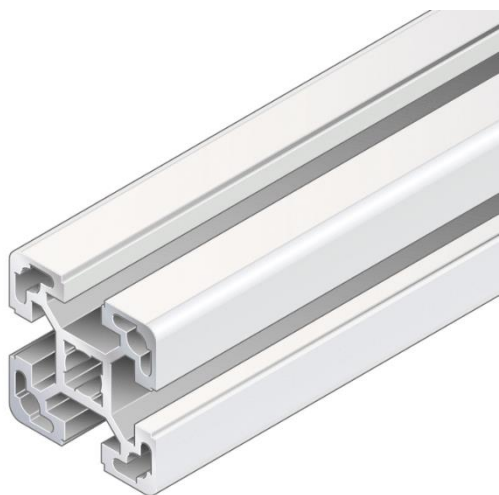

31393

Slika 16. Aluminijski profil [6]

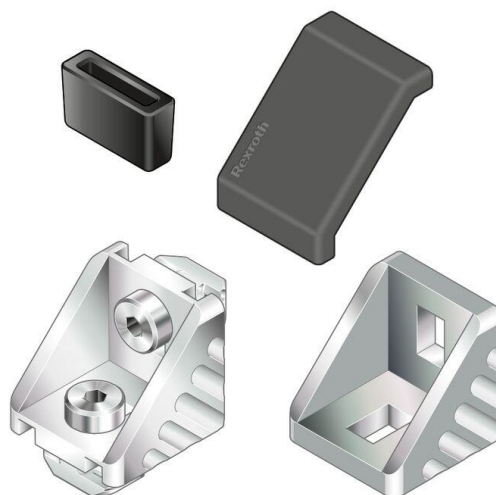

Slika 15. Kutni spojni element [6]

Odabran profil 80X80L optimalni je izbor s obzirom na robusnost i stabilnost, spojevi između profila osigurani su kutnim spojnim elementima. Gornji horizontalni profil služiti će kao nosač pneumatskog cilindra. On je pomičan po vertikalnoj osi, dopušta pozicioniranje u novi položaj i zatezanjem vijaka, osigurava traženi položaj pneumatskog aktuatora.

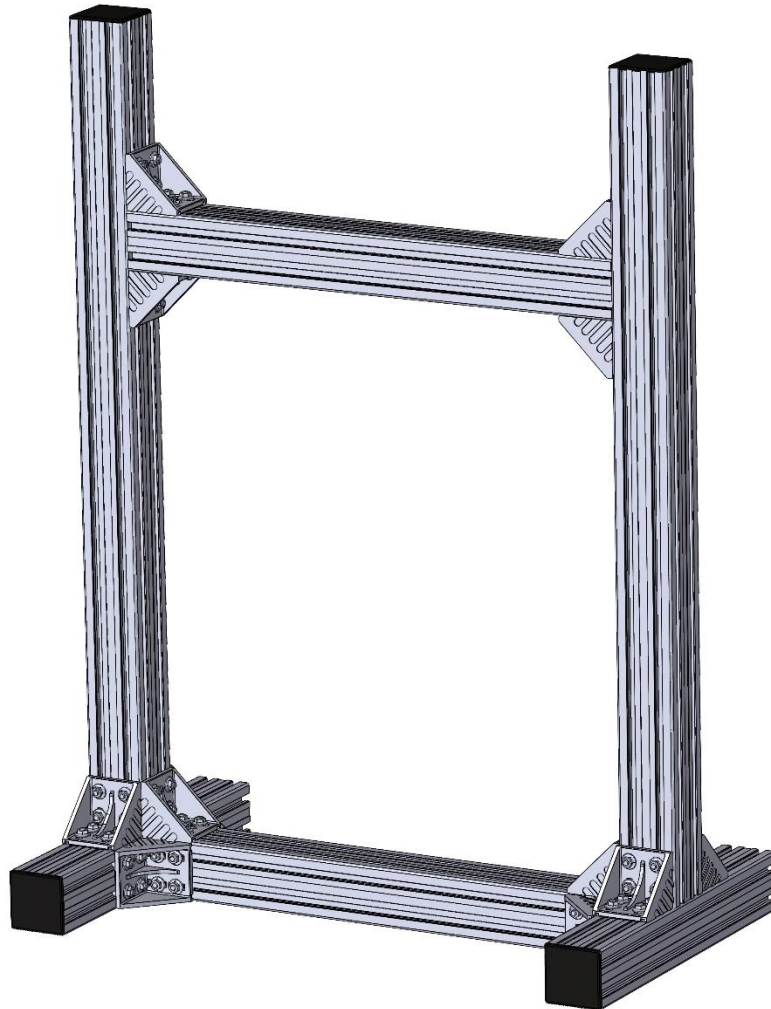

**Slika 17. 3D model nosive konstrukcije sustava**

## 4.2. Projektiranje pneumatskog dijela sustava

Prema simulacijskom modelu sustava umaralice [Slika 12.] odabiremo pneumatske komponente koje zadovoljavaju karakteristike sustava. Proizvođač pneumatskih komponenti je tvrtka SMC, koja je izabrana zbog trajnosti, provjerene kvalitete i dobre dobavljalivosti.

### 4.2.1. Pneumatski cilindar

Iz zahtjeva za ostvarivanje sile do 10 000 N i korištenje standardnih industrijskih komponenti koje koriste tlakove do 9 bara određujemo potreban promjer klipa pneumatskog cilindra.

$$p = \frac{F}{A} \quad (1)$$

$$A = \frac{d^2 \pi}{4} \quad (2)$$

Uvrštavanjem (2) u (1) i izlučivanjem promjera  $d$  dobivamo:

$$d_i = \sqrt{\frac{4 F}{p \pi}} \quad (3)$$

$$d_i = \sqrt{\frac{4 * 10\,000}{9 * 10^5 * \pi}} = 118.94 \text{ mm}$$

Prema izračunatoj vrijednosti promjera  $d_i$  iz kataloga odabiremo prvi veći promjer klipa cilindra koji iznosi  $d = 125$  mm. Do ovog podatka mogli smo doći direktno iz kataloga proizvođača, u tablici koja povezuje teorijsku silu cilindra s promjerom klipa i radnim tlakom [Slika 18.].

Teoretska sila cilindra [N]

Promjer klipa [mm]	Promjer klipnjače [mm]	Kretanje klipnjače	Tlak [MPa]									
			0,1	0,2	0,3	0,4	0,5	0,6	0,7	0,8	0,9	1,0
100	30	van	785	1.571	2.356	3.142	3.927	4.712	5.498	6.283	7.069	7.854
		unutra	715	1.429	2.144	2.859	3.574	4.288	5.003	5.718	6.432	7.147
125	32	van	1.227	2.454	3.682	4.909	6.136	7.363	8.590	9.817	11.045	12.272
		unutra	1.147	2.294	3.440	4.587	5.734	6.881	8.027	9.174	10.321	11.468
160	40	van	2.011	4.021	6.032	8.042	10.053	12.064	14.074	16.085	18.096	20.106
		unutra	1.885	3.770	5.655	7.540	9.425	11.310	13.195	15.080	16.965	18.850

Slika 18. Teorijska sila cilindra [7]

Proizvođač nudi 4 osnovna modela cilindara:

- Glatki cilindar (eng. *Smooth cylinder*)
- Cilindar za niske brzine novi model (eng. *Low speed cylinder new model*)
- Cilindar za niske brzine (eng. *Low speed cylinder*)
- Standardni cilindar (eng. *Standard cylinder*)

Iz zajedničkog prikaza radnih područja osnovnih modela [Slika 19.] vidljivo je da male brzine klipa cilindra uz mali tlak u komorama je moguće postići isključivo glatkim i sporohodnim cilindrima nove generacije. Ta karakteristika bila je presudna pri odabiru cilindra, jer je u ispitivanjima potrebno ostvariti relativno male sile koje su direktno povezane s tlakom u komorama pri sporim promjenama reference. Odabran je glatki cilindar zbog ograničenog promjera klipnjače sporohodnih cilindara nove generacije.

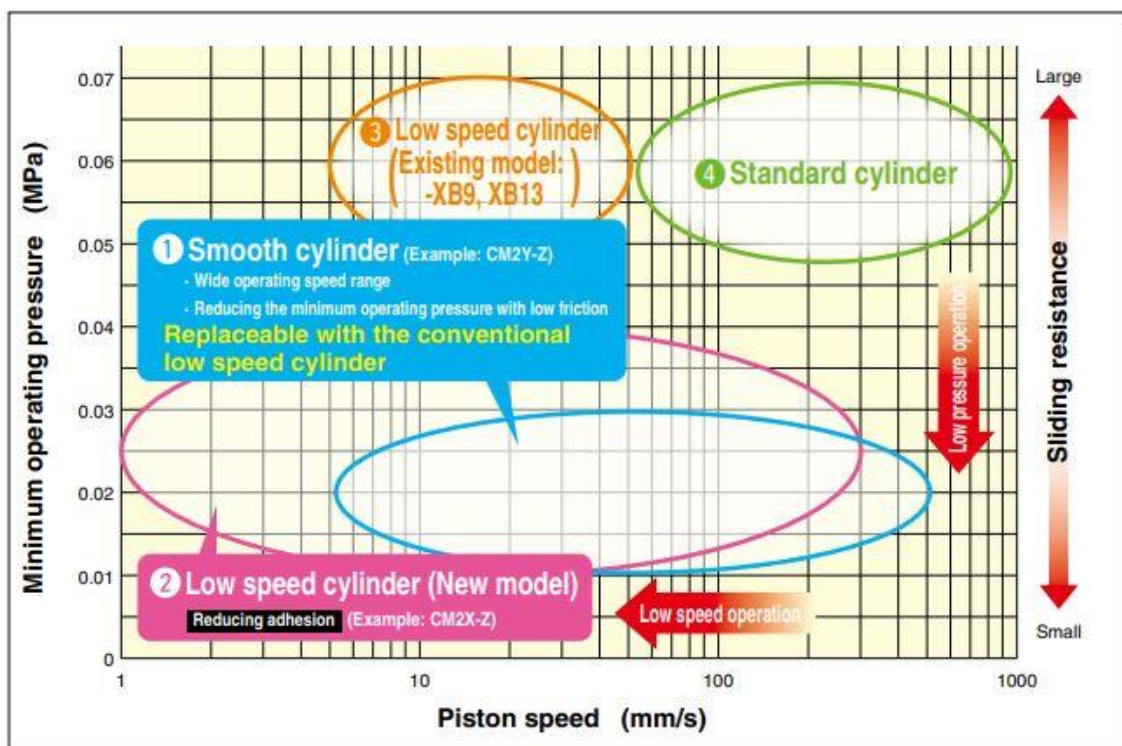

Slika 19. Područje rada modela cilindara [7]

Spajanje cilindra na konstrukciju izvedeno je preko dvije standardne prirubnice cilindra. Jedna je vijcima spojena za cilindar, a druga centrirana iznad profila, a zatim su obje prirubnice povezane vijcima.



**Slika 20. Pneumatski cilindar**

#### **4.2.2. Proporcionalni tlačni regulator**

Za reguliranje tlaka u komori cilindra koristi se proporcionalni tlačni regulator. Odabrani model ITV2050-312N3 s pneumatske strane sadrži 3 spoja. Na prvi ulaz dolazi vod s kompresora, drugi izlaz iz regulatora spaja se s cilindrom, a treći izlaz predstavlja vod za rasterećenje na koji se spaja prigušnik buke. Upravljanje regulatorom vrši se pomoću strujnih ili naponskih signala. U industriji se češće koriste strujni signali zbog manjih smetnji, takva konfiguracija zahtjeva još dodatne pretvornike, budući da industrijska računala u standardnim izvedbama najčešće imaju naponski upravljive izlaze.



**Slika 21. ITV- proporcionalni tlačni regulator [7]**

Regulator se napaja standardnim industrijskim naponom od 24V, upravljački naponski signal je u rasponu od 0 do 10 V. Regulator je u normalnom stanju potpuno otvoren. Prilikom dovođenja upravljačkog signala izlaz tlaka iz regulatora može poprimiti vrijednost od 0.005 do 0.9 MPa. Regulator tlaka u sebi sadrži manometar koji mjeri tlak izlaznog zraka, njegovim spajanjem vrši se provjera i po potrebi regulacija izlaznog tlaka. Vidljivo je iz slike [Slika 22.] da je karakteristika tlačnog regulatora linearna unutar odstupanja od  $\pm 1\%$ , postoji vrlo mala (zanemariva) petlja histereze ispod 0.5%. Ponovljivost signala je gotovo idealna te odstupanje iznosi do  $\pm 0,5\%$ .

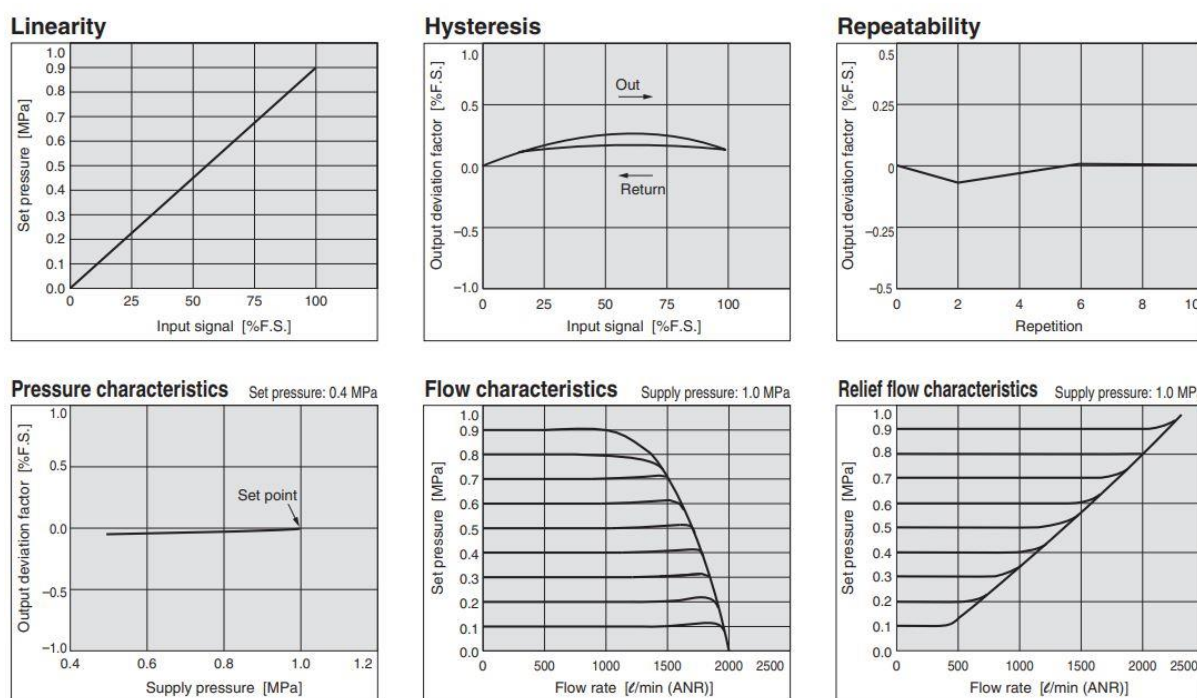

Slika 22. Karakteristika ITV 205X serije [7]

#### 4.2.3. Pripremna grupa

Na pneumatski ulaz u sustav postavljena je standardna pripremna grupa koja se sastoji od ručnog razvodnika 3/2 za puštanje zraka u sustav, regulatora i filtera. Prema tehničkoj dokumentaciji proizvođača nije potrebno provoditi zauljivanje. Izlaz iz pripreme grupe kontroliran je s naponski upravljivim 3/2 razvodnikom koji omogućuje protok zraka u sustav prilikom ispitivanja. Uloga tlačne sklopke je da svojim signalom daje informaciju upravljačkom računalu postoji li stlačeni zrak na izlazu iz pripreme grupe. Ova informacija je od izuzetne važnosti prilikom rada s proporcionalnim regulatorima tipa ITV, jer prilikom rada bez stlačenog zraka na ulazu u regulator može doći do trajnog oštećenja.

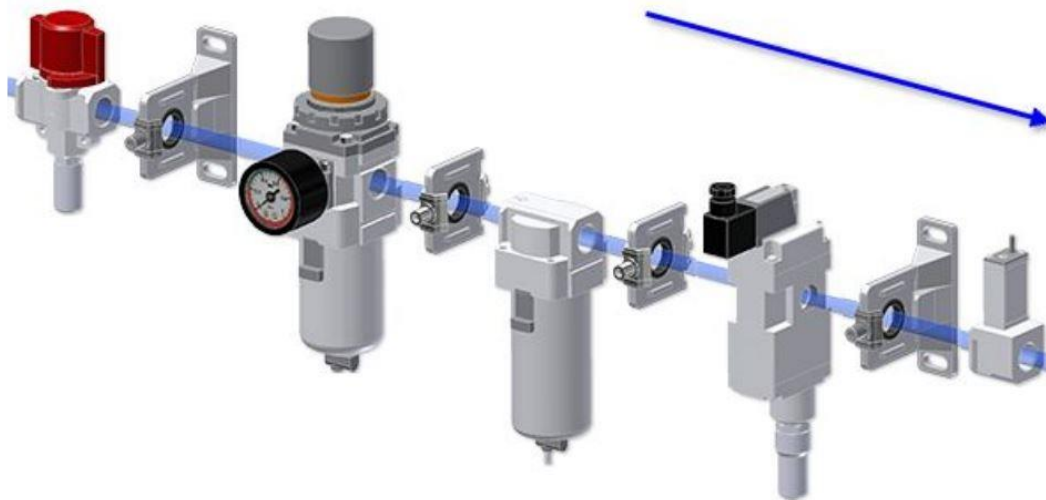

Slika 23. 3D model pripreme grupe [7]

#### 4.2.4. Ostale pneumatske komponente

Na priključke komora cilindra dodani su prigušno nepovratni ventili, zbog mogućnosti podešavanja protoka te osiguravanje u slučaju iznenadnog pomaka klipnjače cilindra u stranu suprotnu od regulirane. Manometri spojeni na komore cilindra omogućuju direktno očitavanje tlaka u njima. Cijeli sustav spojen je s cijevima od poliuretana promjera 10 mm, a sustav manometara cijevima promjera 6 mm.



Slika 24. Prigušno nepovratni ventili [7]



#### 4.2.5. Pneumatska shema sustava

Na shemi [Slika 25.] povezujemo ranije opisane komponente u funkcionalnu cjelinu.

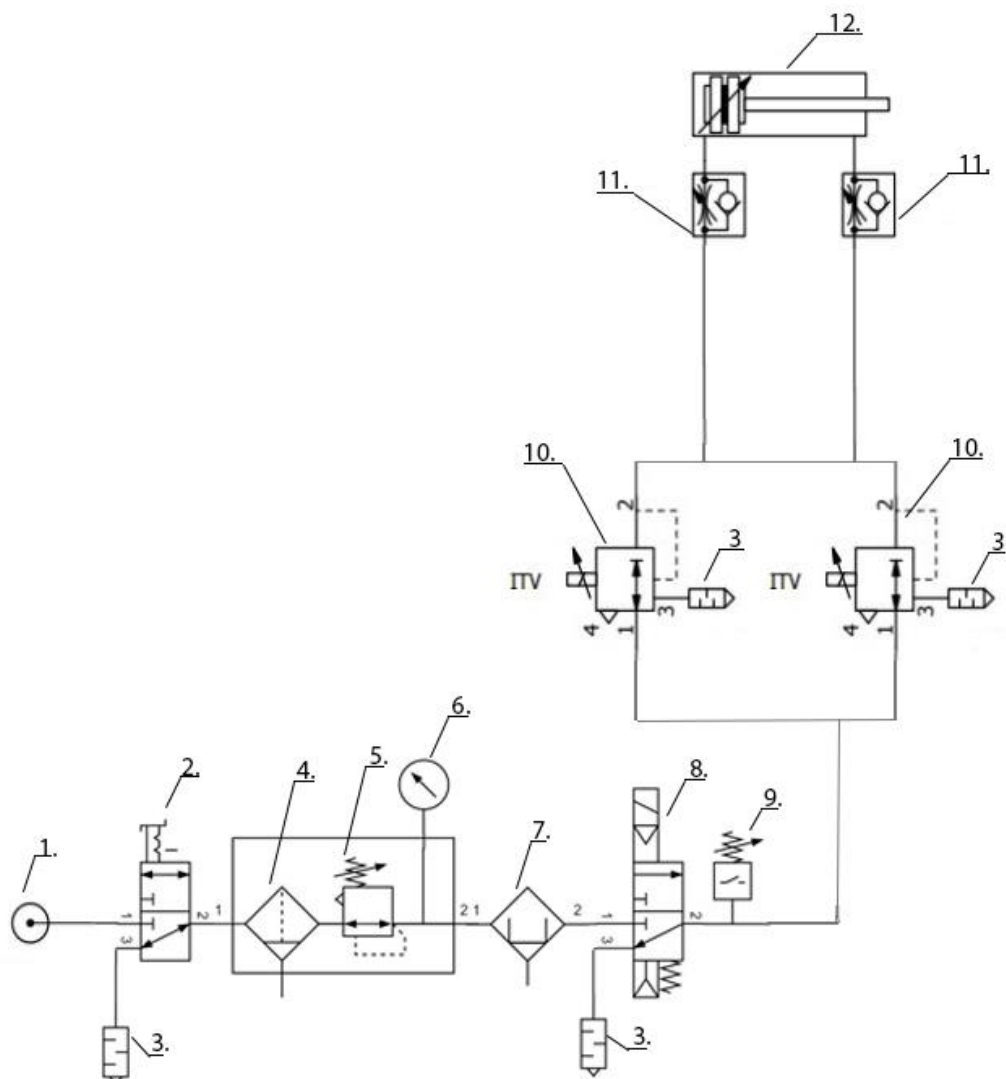

Slika 25. Shema pneumatskog kruga

- |                        |   |
|------------------------|---|
| 1. Kompresor           | 7. Mikro filter                         |
| 2. Ručni razvodnik 3/2 | 8. Elektromagnetski pilot razvodnik 3/2 |
| 3. Prigušnik buke      | 9. Tlačna sklopka                       |
| 4. Filter glavnog voda | 10. Proporcionalni tlačni regulator     |
| 5. Regulator tlaka     | 11. Prigušno nepovratni ventil          |
| 6. Manometar           | 12. Dvoradni cilindar                   |

#### 4.2.6. 3D model projektiranog pneumatskog sustava

Na slici [Slika 26.] prikazan je model nosive konstrukcije s ugrađenim pneumatskim sustavom.

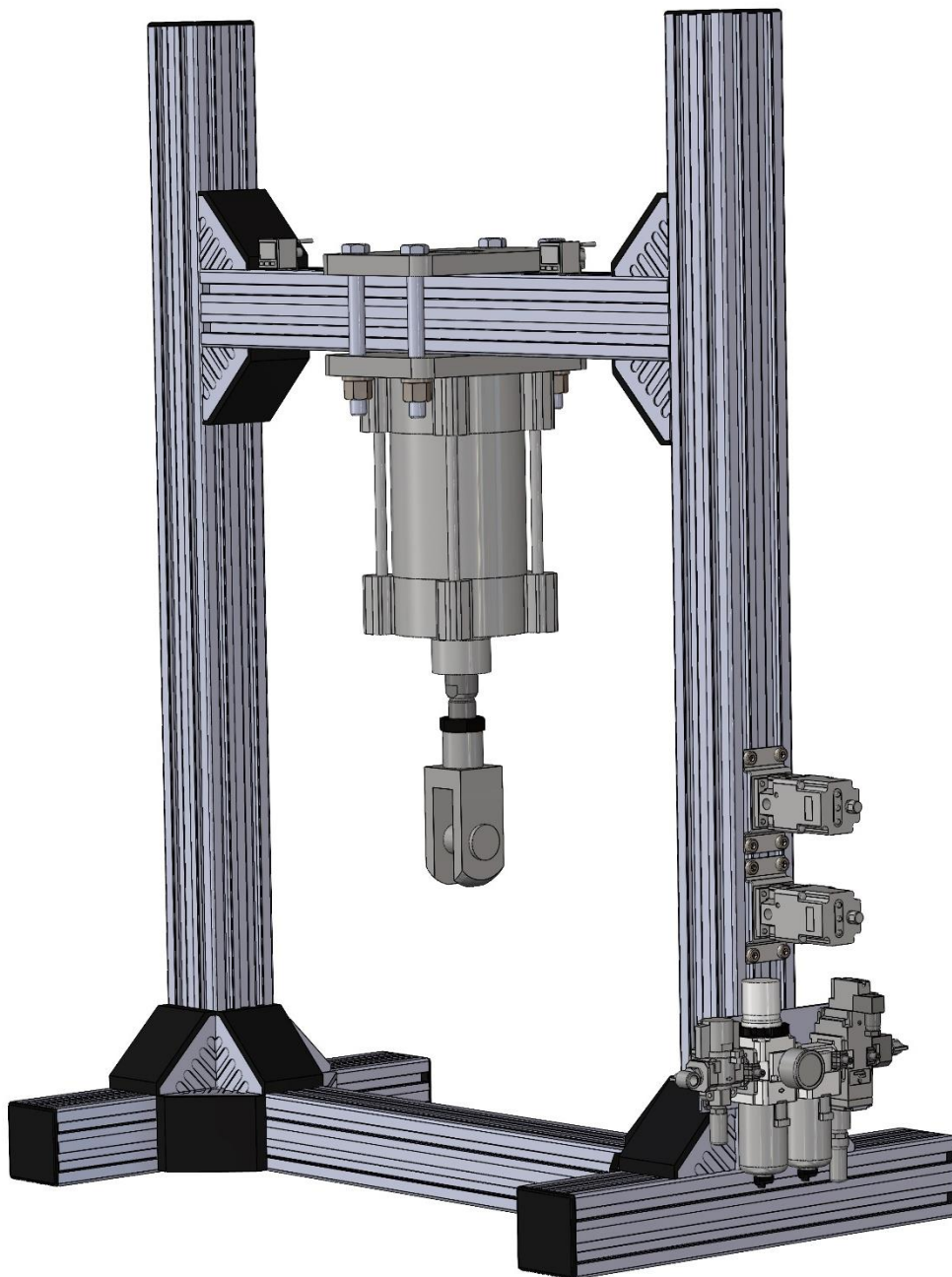

Slika 26. Projektirani 3D model s pneumatskim sustavom

### 4.3. Projektiranje električnog dijela sustava

#### 4.3.1. Upravljačka jedinica

Upravljačka jedinica zadužena je za upravljanje svih komponenti sustava, omogućava prikaz mjerenih podataka, njihovu obradu i pohranu. Zbog velikog broja operacija koje mora istovremeno obaviti razvijene su posebne upravljačke jedinice koje se programiraju u posebnim programskim jezicima. Industrijska računala, odnosno u praksi poznatija pod nazivom PLC (programabilni logički kontroler), sustavi su namijenjeni za rad u industrijskom okolišu kojeg karakteriziraju povišene elektro-magnetske smetnje, vlažnost, prašina, vibracije i slično. Omogućavaju direktno priključivanje senzora i aktuatora, a ta karakteristika usko je povezana s prethodnom za rad u industrijskom okolišu. Težnja je smanjiti broj dodatnih modula koji se moraju ugraditi između upravljačke jedinice i aktuatora ili senzora, zbog jednostavnosti ugradnje, njihovog održavanja te smanjenje mjesta mogućih kvarova. Cijeli operacijski sustav razvijen je s ciljem da se boolova logika može optimalno obrađivati. Upravljački sustavi i njihovi dodaci sličnih su dimenzija, konektori namijenjeni za spajanje uvijek su optimirani tako da njihovo spajanje bude izvedeno na jednostavan i kvalitetan način, takva izvedba podsjeća na samo ugrađivanje kartica. Jedno industrijsko računalo nije dovoljno za upravljanje i automatiziranje cijelog procesa te je zato važan način na koji uređaji međusobno komuniciraju. Razvijeni su standardni načini komunikacija poput Profibus, Industrial Ethernet i Multi-Point Interface – Siemens (MPI) kako bi sustavi bili što robusniji i jednostavniji za povezivanje.

Controllino je industrijsko računalo koje većinu svojih karakteristika dijeli sa standardnim PLC-om. Jedna od glavnih razlika upravo je način programiranja, budući da je uređaj u potpunosti kompatibilan s Arduino programskim okruženjem. Standardni načini programiranja PLC-a su blok dijagrami, Ladder dijagrami i Statment List. Kvaliteta i pouzdanost PLC-a dovela je do toga da većina industrijskih postrojenja koristi upravo ove uređaje, no zbog svoje specifičnosti programiranja, fiksiranih vremena ciklusa, zaključavanja dobavljača i drugih ograničenja razvijen je sustav, kao što je Controllino. Tvrtka Arduino razvija vlastiti hardver i softver otvorenog koda, njihovi proizvodi koriste različite mikrokontrolere, s različitim setovima ulazno-izlaznih jedinica, dodacima za proširivanje i mrežnim svojstvima. Vidljivo je da su oba pristupa vrlo slična s različitim radnim okruženjem. Arduino koristi vlastiti programski jezik koji je vrlo sličan C++, moguće je programiranje pomoću Pythona ili nekog

drugog jezika visoke razine. Program napisan u programskom jeziku putem prevoditelja (eng. *compiler*) pretvara se u binarni kod, prenosi i izvršava na mikrokontroleru.

#### 4.3.2. Karakteristike odabrane upravljačke jedinice

Upravljačka jedinica sustava je Controllino Maxi Power Automation, a odabrana je zbog zadovoljavajućeg broja ulazno izlaznih pinova, mogućnosti regulacije analognih izlaza te mogućnosti prihvata signala sa senzora. Iz dokumentacije je vidljivo da svi analogni i digitalni ulazi imaju djelitelje napona te je moguće direktno spajanje senzora standardnog industrijskog napona od 24V. Digitalni izlazi imaju visoki izlazni napon od 24V, dok je radni napon mikrokontrolera ATmega 2560 5V, digitalni izlazi galvanski su odvojeni te mogu raditi na standardnim industrijskim naponima. Svi ulazno-izlazni konektori posjeduju ESD zaštitu iz čega je vidljivo da se radi o industrijskom računalu koje kombinira prednosti otvorenog koda i načina programiranja sa standardima i sigurnosti standardnih PLC-ova.



Slika 27. Controllino Maxi Power Automation [8]

### 4.3.3. Senzor sile

Senzor sile daje podatke o primjenjenoj sili na klip cilindra. Glavni zahtjev koji je postavljen za izbor senzora su rad u tlačnom i vlačnom području te visoka klasa točnosti. Odabrani senzor oznake HBM Z30A omogućuje precizna mjerenja klase točnosti 00 po ISO 376, ima mjerni opseg od 50 N do 10kN. Uz navedeno osnovne karakteristike ovog senzora su zaštita od preopterećenja, TEDS (eng. *Transducer Electronic Data Sheet*) i dugotrajnost. Ostale karakteristike i klase točnosti dane su u prilogu.



Slika 28. HBM Z30A [9]

Osnovni princip rada senzora sile je tenzometarska traka, koja pod djelovanjem sile mijenja iznos otpora. Trake su spojene u Wheatstoneov most. To je spoj četiri promjenjiva otpornika, u ovom slučaju tenzometarskih traka čiji se ukupni izlaz mijenja ovisno o njihovim vrijednostima.

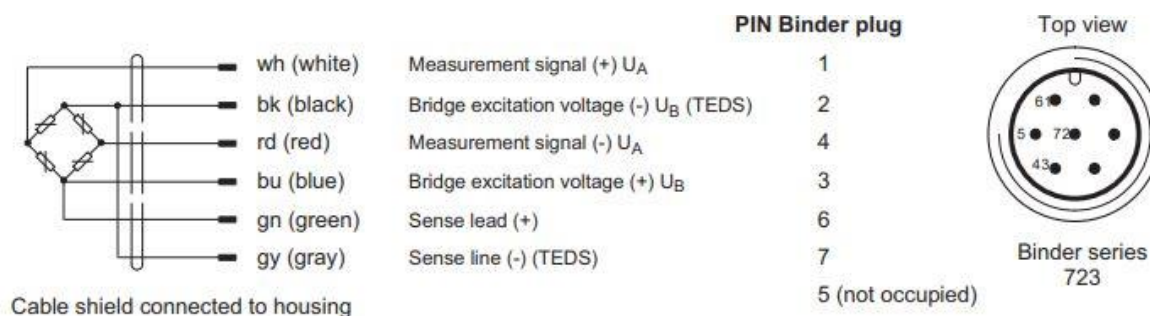

Slika 29. Shema spoja senzora [9]

#### 4.3.4. Mjerno pojačalo

Izlaz senzora sile je vrijednost otpora, a za njegovo očitavanje potrebno je mjerno pojačalo kako bi se podaci mogli očitati s dovoljnom točnošću. Uz senzor odabrano je 1-kanalno pojačalo jednake klase točnosti od istog proizvođača oznake HBM-BM 40.



Slika 30. Mjerno pojačalo BM 40 [9]

Glavne prednosti ovog pojačala su mogućnost spajanja različitih spojeva tenzometarskih traka uz standardne industrijske komunikacijske protokole. Posjeduje i jedan analogni naponski i jedan analogni strujni izlazni signal. Sve postavke poput opcija filtriranja signala i vremena uzrokovanja moguće je podesiti putem web preglednika.

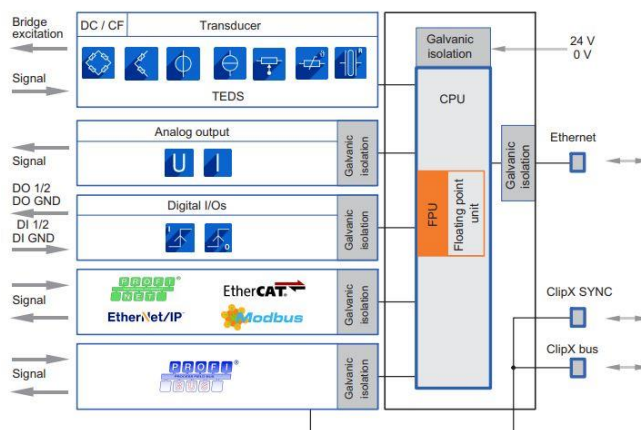

Slika 31. Blok dijagram senzora [9]

#### 4.3.5. HMI (eng. Human Machine Interface)

Uređaj za komunikaciju između sustava i operatera je LCD ekran dijagonale 9", radno okruženje projektiranog sustava su laboratorijski uvjeti, pa nisu potrebni uređaji industrijske kvalitete. Odabrana veličina zaslona biti će dostatna za jednostavan unos potrebnih parametara i prikaz grafova mjernih podataka sa senzora. HMI sustav SK-90DT proizvođača 4DSYSTEMS omogućava jednostavnu komunikaciju i razmjenu podataka s upravljačkom jedinicom.

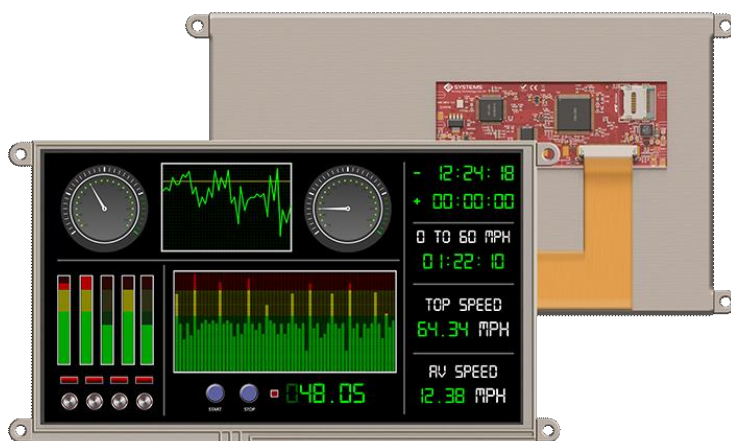

Slika 32. HMI 4DSYSTEMS SK90-DT [10]

#### 4.3.6. Ostale elektroničke komponente

Uključivanje sustava vrši se pomoću grebenaste sklopke koja spaja fazni i nul vod mreže na izvor napajanja koji ima ulogu pretvaranja izmjenične struje u istosmjernu te smanjenje napona mreže na standardnih industrijskih 24V. Sigurnosna sklopka dodana je kao zaštitni uređaj u krug. Prilikom pritiskanja sigurnosne sklopke sve pneumatske komponente ostaju bez napajanja, na taj način zatvara se dovod zraka u sustav te pneumatski dio kruga trenutno prestaje raditi. Sve komponente spojene su i povezane na električni ormar. Na njega su uz ranije navedene komponente također pričvršćena tipkala i signalne led diode.

#### 4.4. 3D model projektiranog sustava

Spajanjem električnog kruga na model projektiranog sustava, dobiven je konačni model sustava.

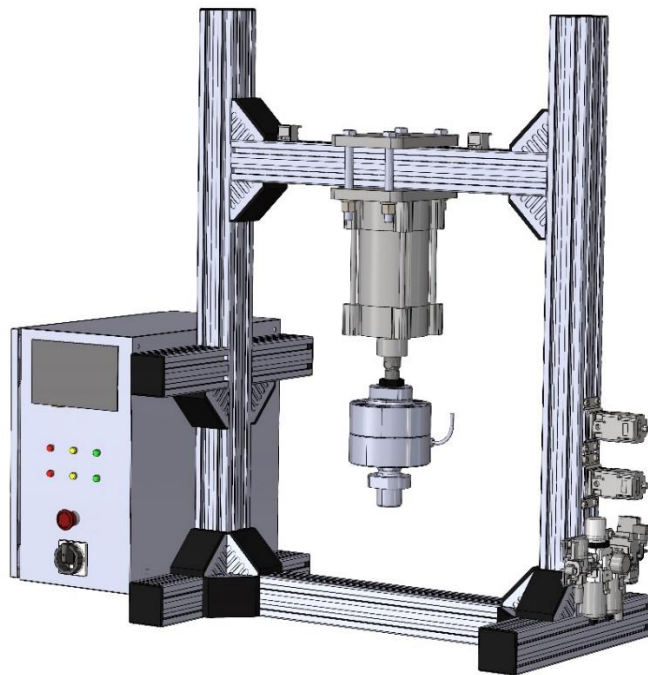

Slika 33. 3D model projektiranog sustava pogled 1.

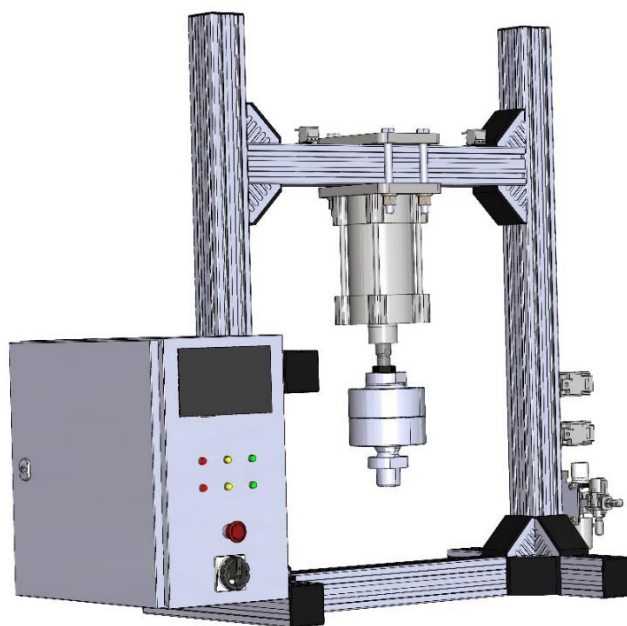

Slika 34. 3D model projektiranog sustava pogled 2.



## 5. Izrada eksperimentalnog postava

Prema projektiranom modelu sustava, izvršena je narudžba svih potrebnih komponenti, potom njihova obrada i spajanje u funkcionalnu cjelinu.

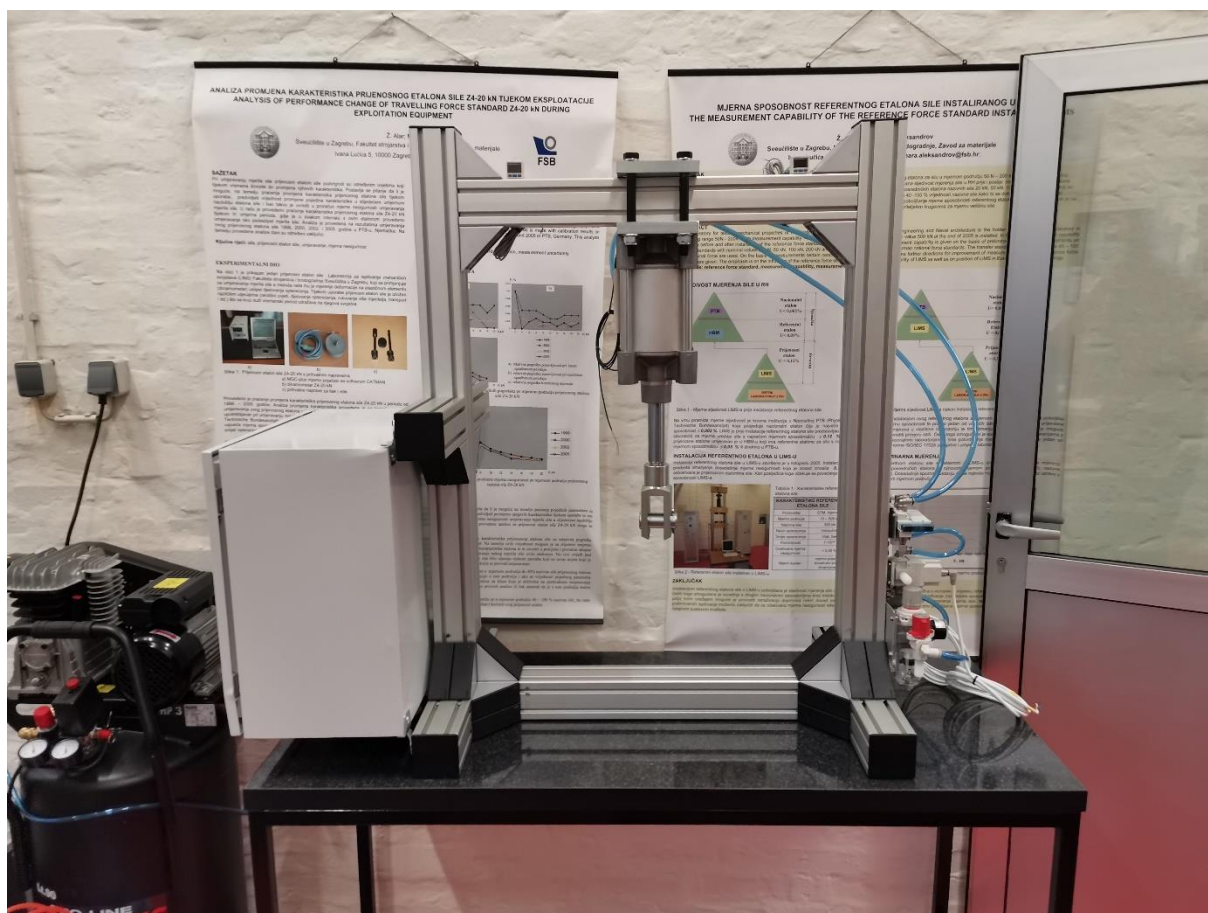

Slika 35. Eksperimentalni postav sustava

## 6. Zaključak

Podaci o dinamičkoj izdržljivosti materijala vrlo su bitni za proračun i konstruiranje. Kontinuirani istraživački rad na ovom području doveo je do razvoja novih metoda i načina ispitivanja s ciljem točnijeg proračuna i prepoznavanja umora materijala. To vodi ka smanjenju loma strojeva i konstrukcija, a posljedično i boljoj zaštiti ljudskih života. U današnjem vremenu kada se sve više koriste novi tipovi kompozitnih i polimernih materijala potrebno je uložiti dodatni napor u istraživanje pojava srodnih umoru materijala. Zbog složenih načina upravljanja dinamičkih ispitnih uređaja postoji relativno mali broj sličnih uređaja na tržištu. Projektirani sustav predstavlja pneumatski sustav za ispitivanje dinamičke izdržljivosti materijala, posjeduje sve karakteristike potrebne za ispitivanje umora novih tipova materijala i standardnih konstrukcijskih materijala. Zbog svoje modularnosti i otvorenosti omogućuje provođenje različitih vrsta statičkih i dinamičkih ispitivanja. Svojim dimenzijama pogodan je za stolnu primjenu u laboratorijskom okruženju.

Izrađeni eksperimentalni postav omogućuje provedbu ispitivanja, te daljnji znanstveno istraživački rad na novim načinima ispitivanja različitih tipova materijala. Upravo je to glavna motivacija za izradu ovog rada. Doprinijeti provedbi dinamičkih ispitivanja materijala s ciljem smanjenja havarija i bolje zaštite ljudskih života.

---

## LITERATURA

- [1] Franz M.: Mehanička svojstva materijala, Fakultet strojarstva i brodogradnje, Zagreb, 1998.
- [2] Ćorić D., Alar Ž.: Odabrana poglavlja iz mehaničkih svojstava materijala-predavanja, Fakultet strojarstva i brodogradnje, Zagreb, 2016.
- [3] Halasz B.: Uvod u termodinamiku, Fakultet strojarstva i brodogradnje, Zagreb, 2015.
- [4] Simscape pneumatski model dvoradnog cilinda:  
<https://www.mathworks.com/help/physmod/simscape/ug/pneumatic-actuation-circuit.html> Datum pristupa: 12.11.2020.
- [5] Način rada programskog paketa Matlab Simscape:  
<https://www.mathworks.com/products/simscape.html> Datum pristupa: 02.10.2020.
- [6] Bosch Rexroth: katalog <https://www.boschrexroth.com/> Datum pristupa: 10.02.2021.
- [7] SMC: katalog <https://www.smc.eu/> Datum pristupa: 12.12.2020.
- [8] Controllino: katalog <https://www.controllino.com/> Datum pristupa: 20.11.2020.
- [9] HBM: katalog <https://www.hbm.com/> Datum pristupa: 10.02.2021.
- [10] 4D Systems: katalog <https://4dsystems.com.au/> Datum pristupa: 10.02.2021.
- [11] Šitum, Ž., Predavanja iz kolegija Pneumatika i hidraulika, 2018
- [12] Petrić, J., Automatska regulacija: uvod u analizu i sintezu, Fakultet strojarstva i brodogradnje, Zagreb; 2012

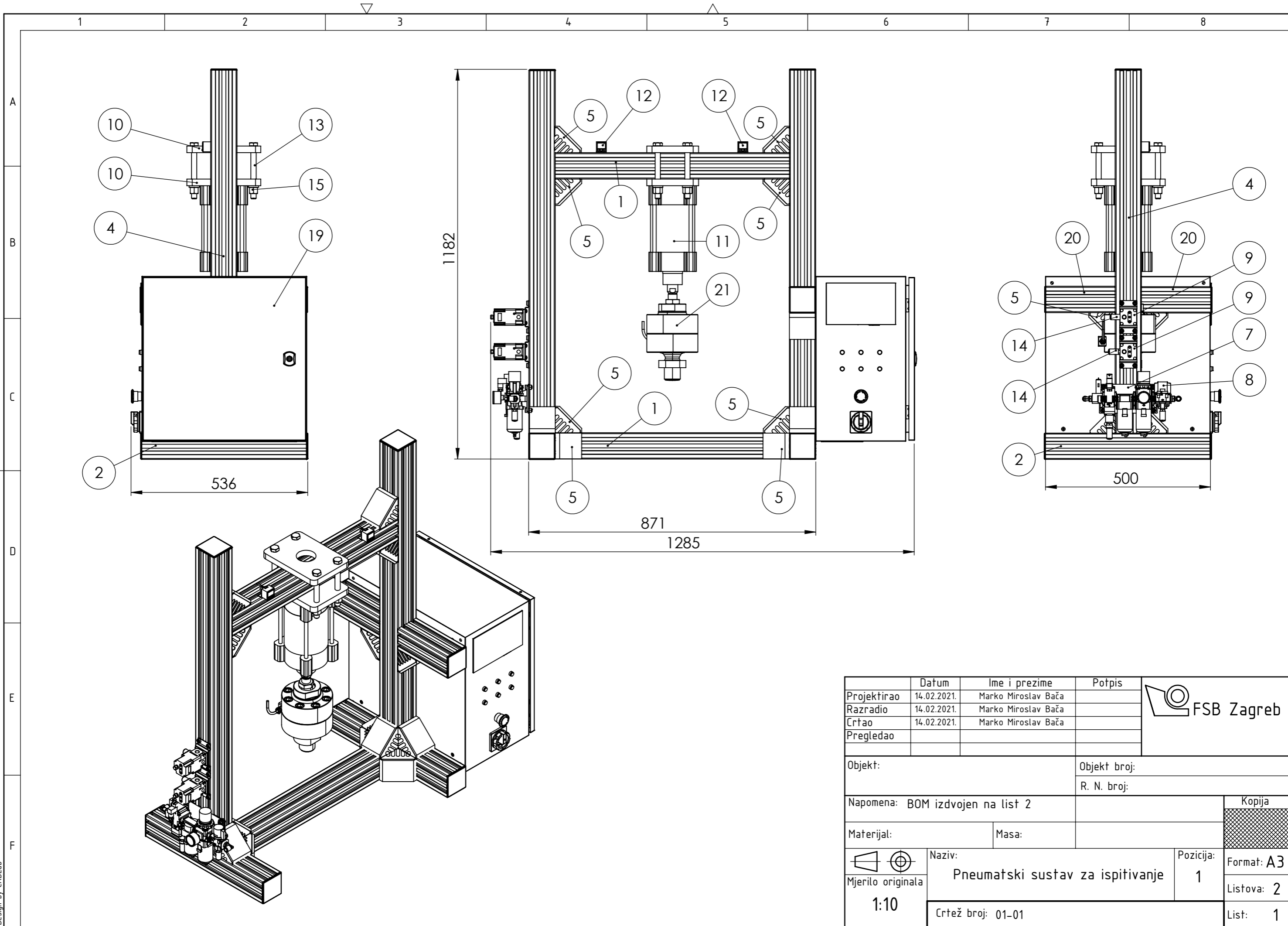

## **PRILOZI**

- I. CD-R disc
- II. Tehnička dokumentacija
- III. Osnovni podaci pneumatskog cilindra – C96YDB125-100
- IV. Osnovni podaci proporcionalnog tlačnog regulatora – ITV 2050-312N3
- V. Lista podataka senzor sile - HBM Z30A
- VI. Lista podataka mjernog pojačala – HBM-BM40
- VII. Lista podataka upravljačke jedinice Controllino
- VIII. Lista podataka HMI sustava - SK90-DT

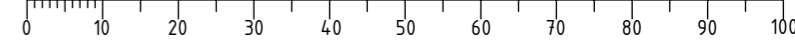

	Datum	Ime i prezime	Potpis	
Projektirao	14.02.2021.	Marko Miroslav Bača		
Razradio	14.02.2021.	Marko Miroslav Bača		
Crtao	14.02.2021.	Marko Miroslav Bača		
Pregledao				
Objekt:			Objekt broj:	
			R. N. broj:	
Napomena: BOM izdvojen na list 2				Kopija
Materijal:		Masa:		
 Mjerilo originala 1:10	Naziv: Pneumatski sustav za ispitivanje		Pozicija: 1	Format: A3
Crtež broj: 01-01			Listova: 2	List: 1



19	Sklop električnog ormarića	1				
18	Matica M8	4	DIN 934			
17	Vijak M8x16	4	DIN 912			
16	Vijak M8x12	8	DIN 912			
15	Samokočna matica M16	4	DIN 985			
14	Prigušnik buke	2	AN20-02		SMC	
13	Vijak M16x160	4	DIN 931	10.9 Fe		
12	Manometar	2			SMC	
11	Pneumatski cilindar	1	C96YDB125-100		SMC	
10	Prirubnica cilindra	2	F5125		SMC	
9	Proporcionalni regulator	2	ITV2050-312BN3		SMC	
8	Pripremna grupa	1			SMC	
7	Ploča	1			SMC	
6	Završna ploča kutnog nosača	12			Bosch Rexroth	
5	Kutni nosač	16		Aluminij	Bosch Rexroth	
4	Aluminijski profil	2	80x80L x1100	Aluminij	Bosch Rexroth	
3	Završna ploča profila	8			Bosch Rexroth	
2	Aluminijski profil	2	80x80L x500	Aluminij	Bosch Rexroth	
1	Aluminijski profil	2	80x80L x710	Aluminij	Bosch Rexroth	
Poz.	Naziv dijela	Kom.	Crtez broj Norma	Materijal	Sirove dimenzije Proizvođač	Masa
	Datum	Ime i prezime		Potpis		
Projektirao	14.02.2021.	Marko Miroslav Bača				
Razradio	14.02.2021.	Marko Miroslav Bača		FSB Zagreb		
Crtao	14.02.2021.	Marko Miroslav Bača				
Pregledao						
Objekt:				Objekt broj:		
				R. N. broj:		
Napomena:				Kopija		
						
Materijal:		Masa:				
		Naziv:		Pozicija:	Format: A4	
Mjerilo originala		BOM sklopnog crteža		1	Listova: 1	
Crtez broj: 01-01				List: 2		

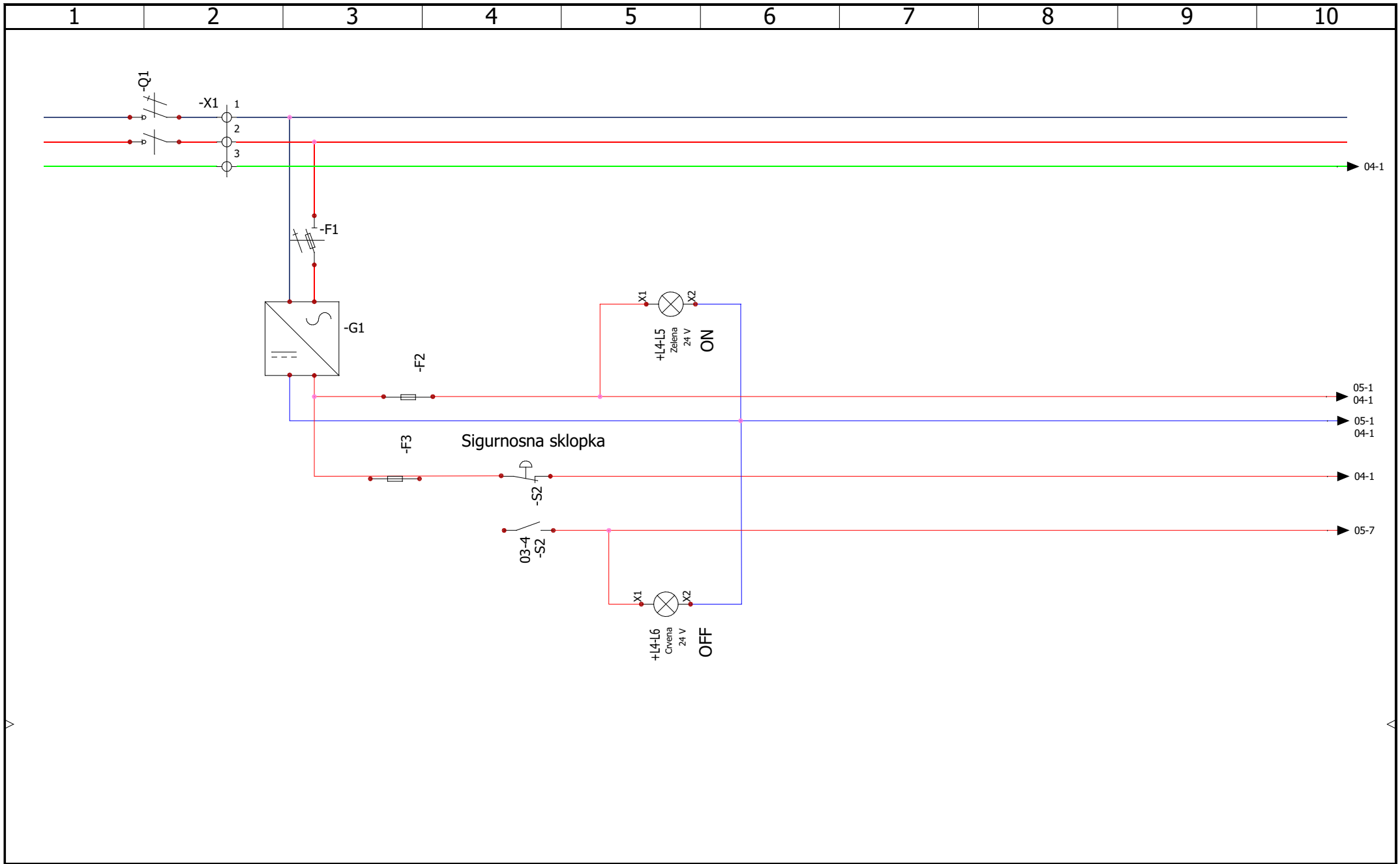

FSB  
Ivana Lučića 5  
10 000 Zagreb

Električne sheme spajanja  
-Napajanje

CONTRACT:

LOCATION:

+L1

01-02

				REVISION
				0
0	16/02/2021	Marko M. Bača		
REV.	DATE	NAME	CHANGES	SCHEME
				03
User data 1			User data 2	

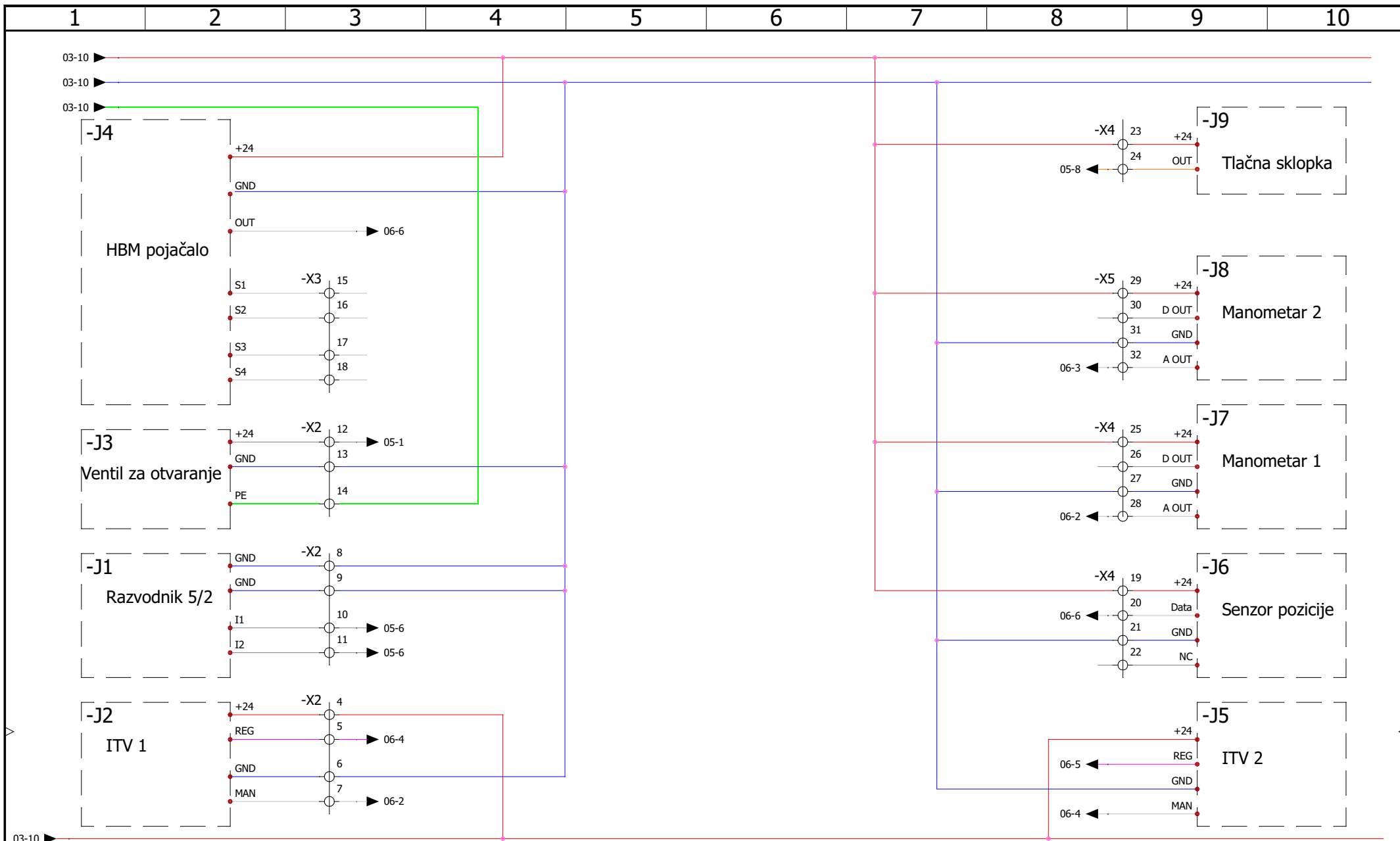

FSB  
Ivana Lučića 5  
10 000 Zagreb

Električne sheme spajanja  
- Ulazno izlazni sklop

CONTRACT:

LOCATION: +L1

01-02

				REVISION
0	16/02/2021	Marko M. Bača		0
REV.	DATE	NAME	CHANGES	SCHEME
				04
User data 1			User data 2	



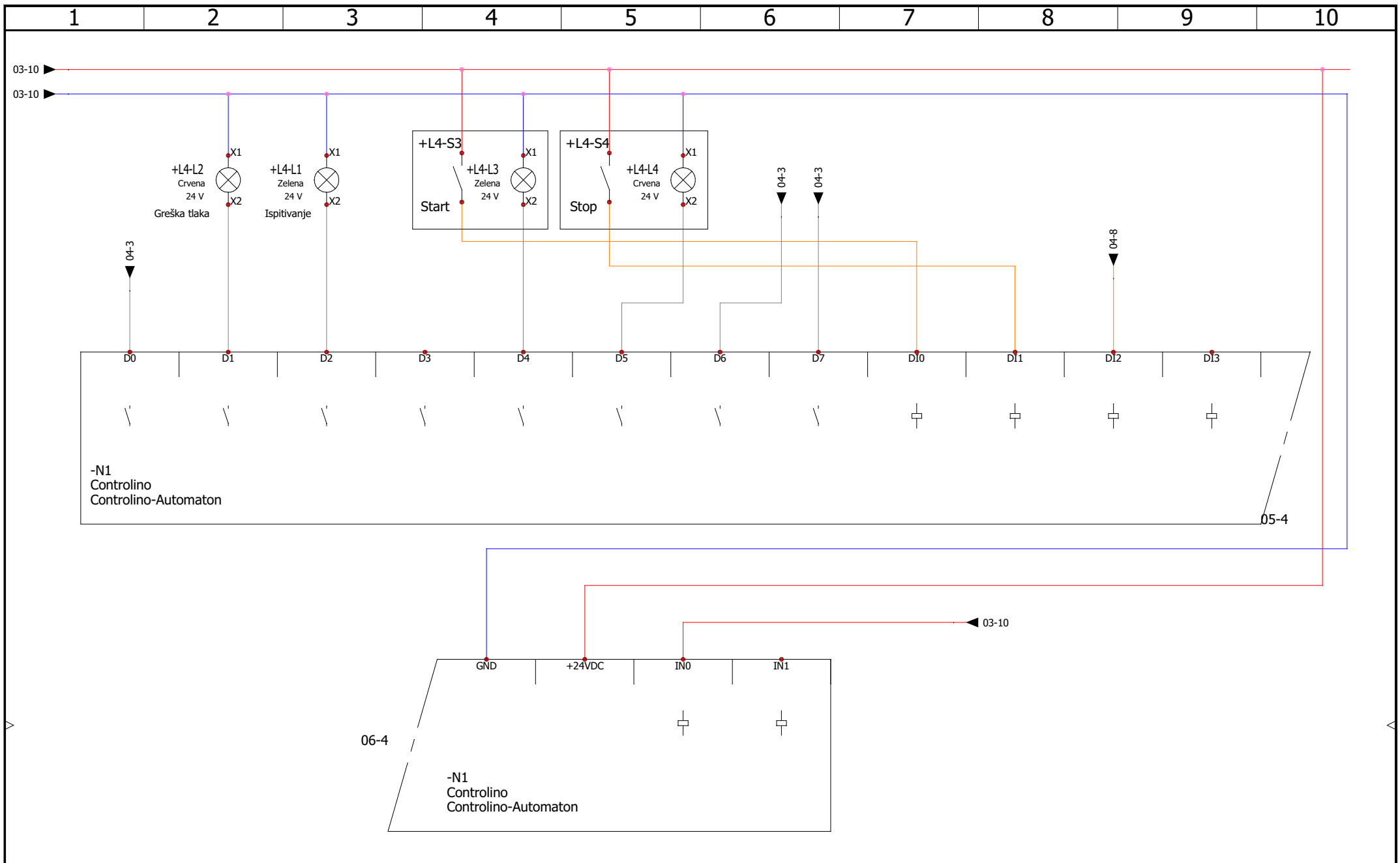

FSB  
Ivana Lučića 5  
10 000 Zagreb

### Električne sheme spajanja -PLC digitalni ulazi/izlazi

CONTRACT:

LOCATION: +L1

01-02

				REVISION
				0
0	16/02/2021	Marko M. Bača		
REV.	DATE	NAME	CHANGES	SCHEME
				05
User data 1			User data 2	

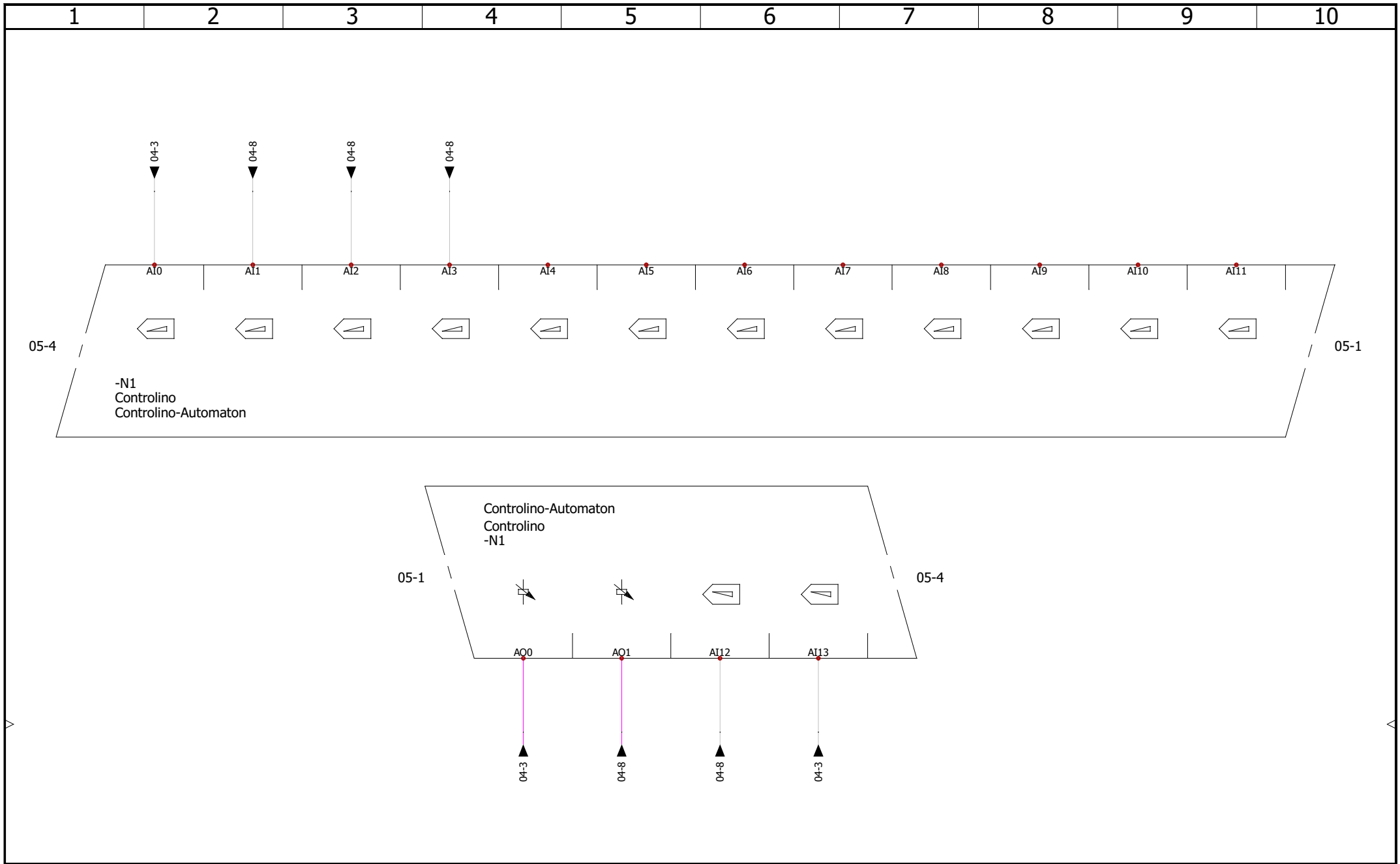

FSB  
Ivana Lučića 5  
10 000 Zagreb

Električne sheme spajanja  
-PLC analogni ulazi/izlazi

CONTRACT:

LOCATION:

+L1

01-02

				REVISION
				0
0	16/02/2021	Marko M. Bača		
REV.	DATE	NAME	CHANGES	SCHEME
				06
User data 1			User data 2	

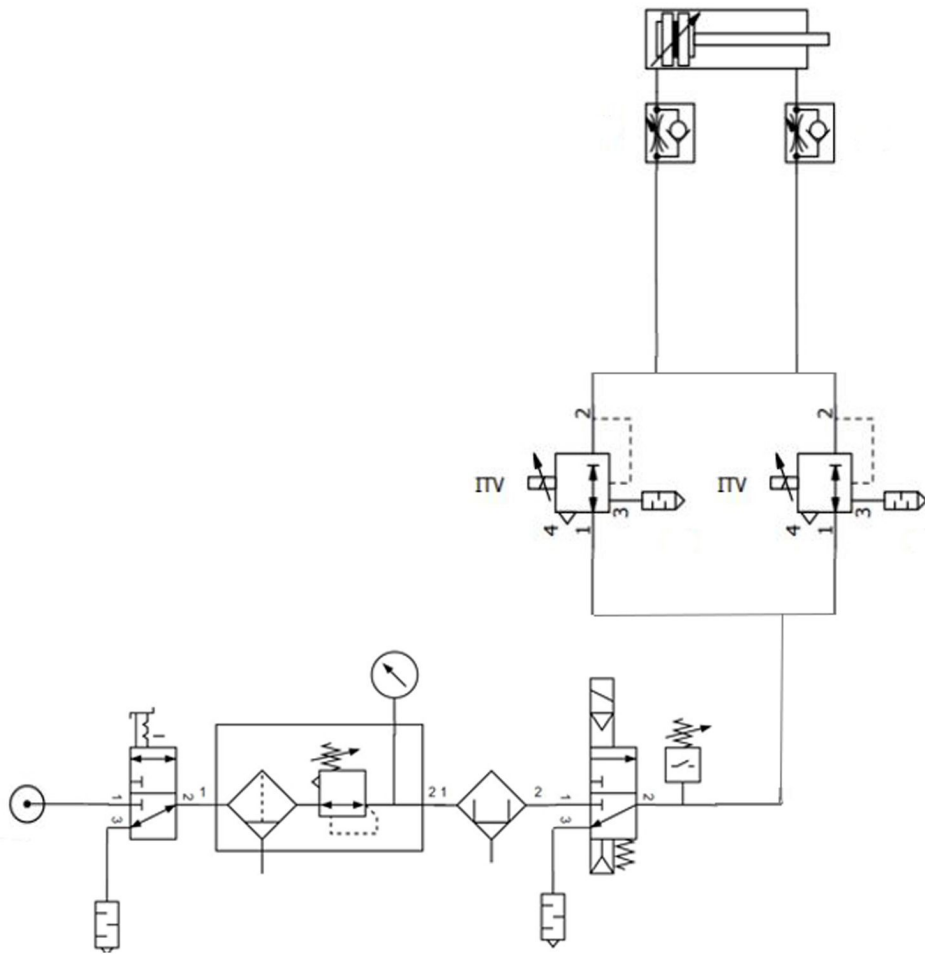

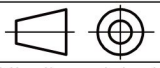
	Datum	Ime i prezime	Potpis	
Projektirao	14.02.2021.	Marko Miroslav Bača		
Razradio	14.02.2021.	Marko Miroslav Bača		
Crtao	14.02.2021.	Marko Miroslav Bača		
Pregledao				
Objekt:			Objekt broj:	
			R. N. broj:	
Napomena:			Kopija	
Materijal:			Masa:	
 Mjerilo originala	Naziv:		Pozicija:	Format: A4
	Pneumatska shema sustava		1	Listova: 1
Crtež broj: 01-03				List: 1

**Designed with a low sliding resistance of the piston, this air cylinder is ideal for applications such as contact pressure control, which requires smooth movements at low pressure.**

**Low sliding resistance**  
Min. operating pressure -0.01 MPa

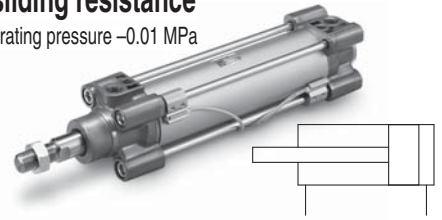

**Sliding resistance** Bi-directional low-friction operation possible.

Pressure can be controlled regardless of its direction.

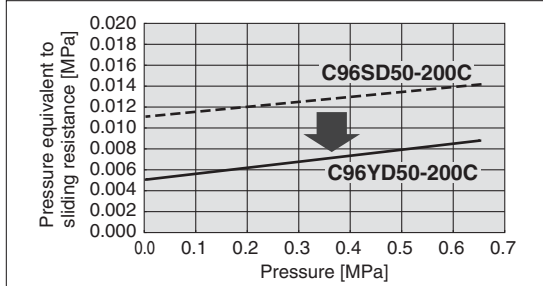

### Application Example

Smooth cylinder combined with precision regulator (e.g. Series IR)

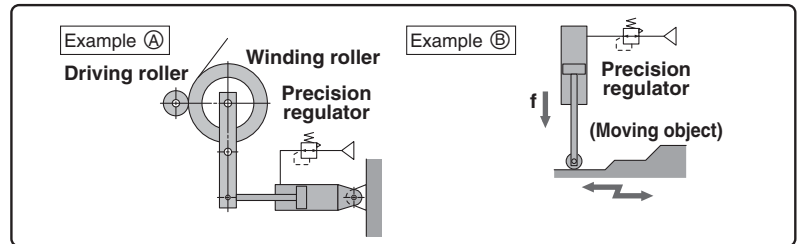

**Made to Order**  
(For details, refer to pages 32 to 41.)

Symbol	Specifications
-XA□	Change of rod end shape
-XC14	Change of trunnion bracket mounting position
-XC7	Tie-rod, tie-rod nut, etc. made of stainless steel
-XC10	Dual stroke cylinder/Double rod type
-XC65	Made of stainless steel (Combination of -XC7 and -XC68)
-XC68	Made of stainless steel (with hard chrome plated piston rod)

Refer to pages 23 to 27 for cylinders with auto switches.

- Auto switch proper mounting position (detection at stroke end) and its mounting height
- Minimum stroke for auto switch mounting
- Auto switch mounting brackets/Part no.
- Operating range

**Dimensions are the same as standard type. For details, refer to pages 7 to 9.**

### Replacement Parts/Seal Kit

Bore size [mm]	Kit no.	Contents
32	C96Y32-PS	Rod seal 1 pc. Piston seal 1 pc. Cylinder tube gasket 2 pcs. Grease pack (10 g) 1 pc.
40	C96Y40-PS	
50	C96Y50-PS	
63	C96Y63-PS	
80	C96Y80-PS	
100	C96Y100-PS	
125	C96Y125-PS	

\* Seal kits consist of items shown above, and can be ordered by using the seal kit number corresponding to each bore size.

\* Only use the grease recommended by SMC. Order using the following part numbers when only maintenance grease is needed.

Volume	Part no.
5 g	GR-L-005
10 g	GR-L-010
150 g	GR-L-150

### Specifications

Bore size [mm]	32	40	50	63	80	100	125
<b>Action</b>	Double acting						
<b>Fluid</b>	Air						
<b>Proof pressure</b>	1.05 MPa						
<b>Maximum operating pressure</b>	0.7 MPa						
<b>Minimum operating pressure</b>	0.02 MPa		0.01 MPa				
<b>Ambient and fluid temperature</b>	Without auto switch: -10 to 70° C (No freezing) With auto switch: -10 to 60° C (No freezing)						
<b>Lubrication</b>	Not required (Non-lube)						
<b>Operating piston speed</b>	5 to 500 mm/s						
<b>Allowable stroke tolerance</b>	Up to 500 stroke: $^{+2}_0$ , 501 to 1000 stroke: $^{+2.4}_0$						
<b>Cushion</b>	Bumper						
<b>Port size</b>	G1/8	G1/4	G1/4	G3/8	G3/8	G1/2	G1/2
<b>Mounting</b>	Basic, Axial foot, Rod flange, Head flange, Single clevis, Double clevis, Centre trunnion						
<b>Allowable leakage rate</b>	0.5 l/min (ANR)						

### Maximum Strokes

Bore size [mm]	Maximum stroke*
32	800
40	800
50	1000
63	1000
80	1000
100	1000
125	1000

Intermediate strokes are available.

\* Please consult with SMC for longer strokes.

### Accessories

Mounting		Basic	Foot	Rod flange	Head flange	Single clevis	Double clevis	Centre trunnion
Standard	Rod end nut	●	●	●	●	●	●	●
	Clevis pin	—	—	—	—	—	●	—
Option	Rod end	●	●	●	●	●	●	●
	Rod clevis	●	●	●	●	●	●	●
	Rod boot	—	—	—	—	—	—	—

\* Do not use a rod end (or floating joint) together with a single clevis with a ball joint (or clevis pivot bracket with a ball joint).

\* Refer to pages 10 to 14 for dimensions and part numbers of the accessories.



# Smooth Cylinders Specific Product Precautions 1

Be sure to read this before handling. Refer to the back cover for Safety Instructions. For Actuator and Auto Switch Precautions, refer to “Handling Precautions for SMC Products” and the Operation Manual on SMC website, <http://www.smc.eu>

## Recommended Pneumatic Circuit

Refer to the diagrams below when controlling speed with the smooth cylinder.

### Warning

#### Horizontal Operation (Speed control)

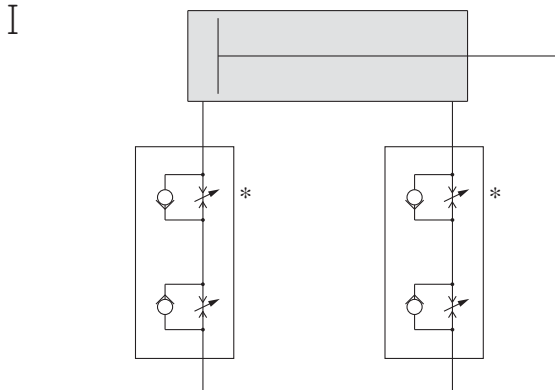

#### Dual speed controller

Speed is controlled by meter-out circuit. Using concurrently the meter-in circuit can alleviate the stick-slip. More stable low speed operation can be achieved than meter-in circuit alone.

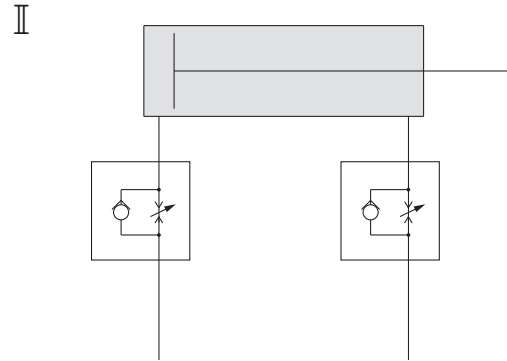

#### Meter-in speed controller

Meter-in speed controllers can reduce lurching while controlling the speed. The two adjustment needles facilitate adjustment.

#### Vertical Operation (Speed control)

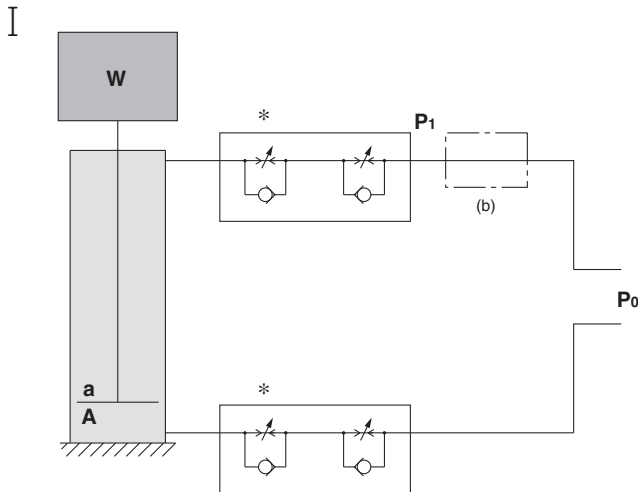

- (1) Speed is controlled by meter-out circuit. Using concurrently the meter-in circuit can alleviate the stick-slip.\*
- (2) Depending on the size of the load, installing a regulator with check valve at position (b) can reduce lurching during descent and operation delay during ascent.  
As a guide,  
when  $W + P_0a > P_0A$ ,  
adjust  $P_1$  to make  $W + P_1a = P_0A$ .

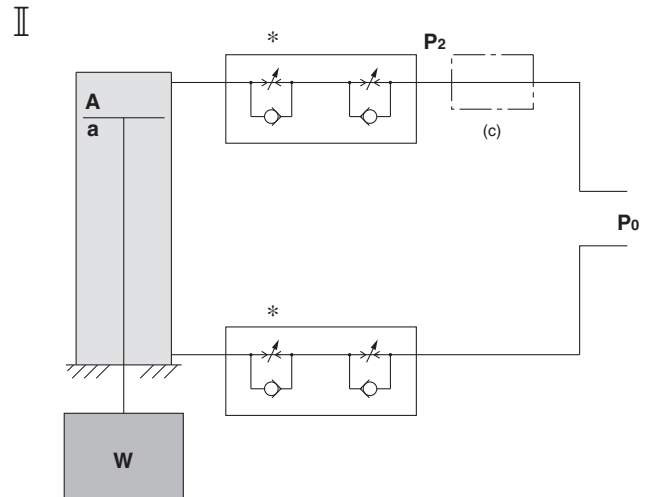

- (1) Speed is controlled by meter-out circuit. Using concurrently the meter-in circuit can alleviate the stick-slip.\*
- (2) Installing a regulator with check valve at position (c) can reduce lurching during descent and operation delay during ascent.  
As a guide,  
adjust  $P_2$  to make  $W + P_2A = P_0a$ .

W: Load [N] P<sub>0</sub>: Operating pressure [MPa] P<sub>1</sub>, P<sub>2</sub>: Reduced pressure [MPa] a: Rod side piston area [mm<sup>2</sup>] A: Head side piston area [mm<sup>2</sup>]

# Electro-Pneumatic Regulator *Series ITV1000/2000/3000*

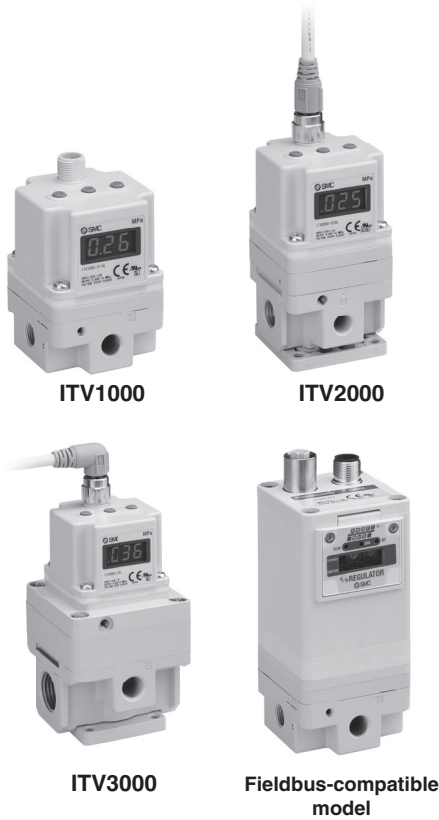

## JIS Symbol

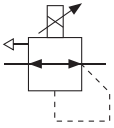

Rated pressure

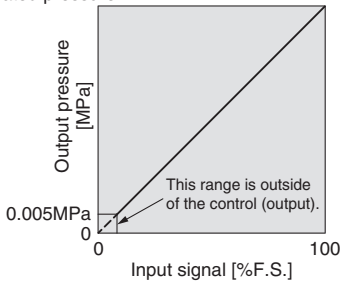

Figure 1. Input/output characteristics chart

## Communication Specifications (CC, DE, PR, RC)

## Standard Specifications

Model	ITV101□ <sup>Note 10</sup>	ITV103□ <sup>Note 10</sup>	ITV105□ <sup>Note 10</sup>
	ITV201□	ITV203□	ITV205□
	ITV301□	ITV303□	ITV305□
Minimum supply pressure	Set pressure +0.1 MPa		
Maximum supply pressure	0.2 MPa	1.0 MPa	
Set pressure range <sup>Note 1)</sup>	0.005 to 0.1 MPa	0.005 to 0.5 MPa	0.005 to 0.9 MPa
Power supply	Voltage	24 VDC ±10%, 12 to 15 VDC	
	Current consumption	Power supply voltage 24 VDC type: 0.12 A or less <sup>Note 8)</sup> Power supply voltage 12 to 15 VDC type: 0.18 A or less	
Input signal	Current type <sup>Note 2)</sup>	4 to 20 mA DC, 0 to 20 mA DC (Sink type)	
	Voltage type	0 to 5 VDC, 0 to 10 VDC	
	Preset input	4 points (Negative common), 16 points (No common polarity)	
Input impedance	Digital input	10 bit (parallel)	
	Current type	250 Ω or less <sup>Note 6)</sup>	
	Voltage type	Approx. 6.5 kΩ	
	Preset input	Power supply voltage 24 VDC type: Approx. 4.7 kΩ; Power supply voltage 12 VDC type: Approx. 2.0 kΩ	
Output signal <sup>Note 3)</sup> (monitor output)	Digital input	Approx. 4.7 kΩ	
	Analogue output	1 to 5 VDC (Output impedance: Approximately 1 kΩ) 4 to 20 mA DC (Sink type) (Load impedance: 250Ω or less) Output accuracy within ±6% (Full span)	
Switch output	NPN open collector output: Max. 30 V, 80 mA PNP open collector output: Max. 80 mA		
Linearity	Within ±1% (Full span)		
Hysteresis	Within 0.5% (Full span)		
Repeatability	Within ±0.5% (Full span)		
Sensitivity	Within 0.2% (Full span)		
Temperature characteristics	Within ±0.12% (Full span)/°C		
Output pressure display <sup>Note 4)</sup>	Accuracy	±2%F.S. ±1 digit	
	Minimum unit	MPa: 0.001, kgf/cm <sup>2</sup> : 0.01, bar: 0.01, psi: 0.1 <sup>Note 5)</sup> , kPa: 1	
Ambient and fluid temperature	0 to 50°C (No condensation)		
Enclosure	IP65		
Weight <sup>Note 9)</sup>	ITV10□□	Approx. 250 g (without options)	
	ITV20□□	Approx. 350 g (without options)	
	ITV30□□	Approx. 645 g (without options)	

Note 1) Please refer to Figure 1 for the relationship between set pressure and input. Because the maximum set pressure differs for each pressure display, refer to page 45.

Note 2) 2-wire type 4 to 20 mA DC is not available. Power supply voltage (24 VDC or 12 to 15 VDC) is required.

Note 3) Select either analogue output or switch output.

Further, when switch output is selected, select either NPN output or PNP output.

Note 4) Adjustment of numerical values such as the zero/span adjustment or preset input type is set based on the minimum units for output pressure display (e.g. 0.01 to 0.50 MPa). Note that the unit cannot be changed.

Note 5) The minimum unit for 0.9 MPa (130 psi) types is 1 psi.

Note 6) Value for the state with no over current circuit included. If an allowance is provided for an over current circuit, the input impedance varies depending on the input current. This is 350 Ω or less for an input current of 20 mA DC.

Note 7) The above characteristics are confined to the static state. When air is consumed on the output side, the pressure may fluctuate.

Note 8) For communication models, the maximum current consumption is 0.16 A or less.

Note 9) For communication models, add roughly 80 g to the weight (100 g for the PROFIBUS DP).

Note 10) The ITV1000 series is a Grease-free specification (Wetted parts).

Model	ITV□□□0-CC	ITV□□□0-DE	ITV□□□0-PR	ITV□□□0-RC
Protocol	CC-Link	DeviceNet™	PROFIBUS DP	RS-232C
Version <sup>Note 1)</sup>	Ver 1.10	Volume 1 (Edition 3.8), Volume 3 (edition 1.5)	DP-V0	—
Communication speed	156 k/625 k 2.5 M/5 M/10 M bps	125 k/250 k/500 k bps	9.6 k/19.2 k/45.45 k 93.75 k/187.5 k/500 k 1.5 M/3 M/6 M/12 M bps	9.6 kbps
Configuration file <sup>Note 2)</sup>	—	EDS	GSD	—
I/O occupation area (input/output data)	4 word/4 word, 32 bit/32 bit (per station, remote device station)	16 bit/16 bit	16 bit/16 bit	—
Communication data resolution	12 bit (4096 resolution)	12 bit (4096 resolution)	12 bit (4096 resolution)	10 bit (1024 resolution)
Fail safe	HOLD <sup>Note 3)</sup> /CLEAR (Switch setting)	HOLD/CLEAR (Switch setting)	CLEAR	HOLD
Electric insulation <sup>Note 4)</sup>	No	No	Yes	No
Terminating resistor	—	—	Built into the product (Switch setting)	—

Note 1) Note that version information is subject to change.

Note 2) Configuration files can be downloaded from the SMC's website: <http://www.smcworld.com>

Note 3) The output HOLD value when a CC-Link communications error occurs can be set based on the bit area data.

Note 4) The insulation between the electrical signal of the communication system and ITV power supply.

# Series ITV1000/2000/3000

## Series ITV101

### Linearity

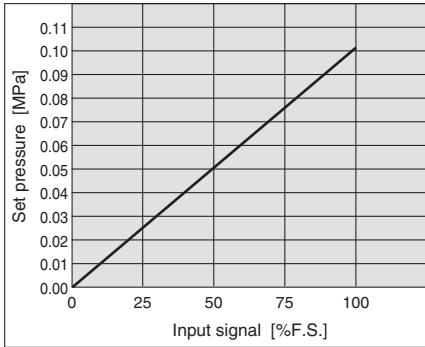

### Hysteresis

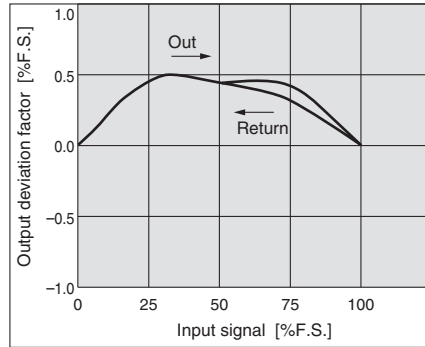

### Repeatability

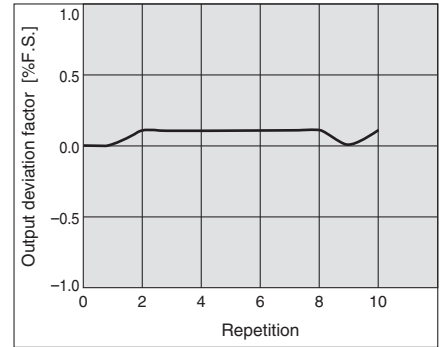

### Pressure characteristics Set pressure: 0.05 MPa

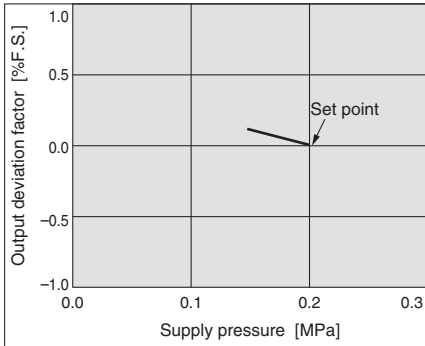

### Flow characteristics Supply pressure: 0.2 MPa

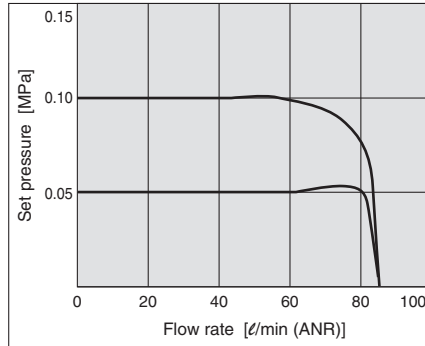

### Relief flow characteristics Supply pressure: 0.2 MPa

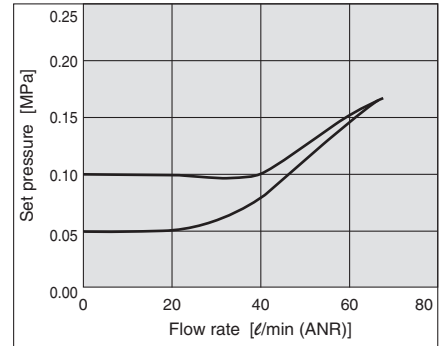

## Series ITV201

### Linearity

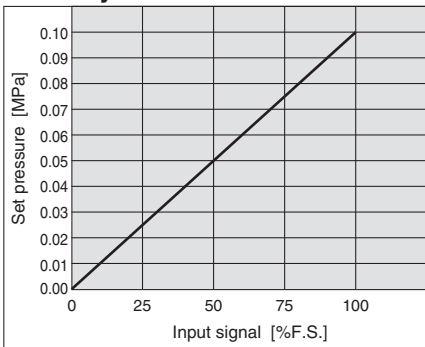

### Hysteresis

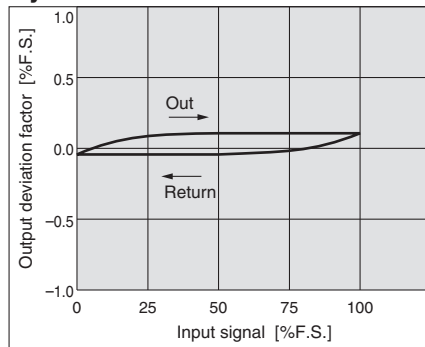

### Repeatability

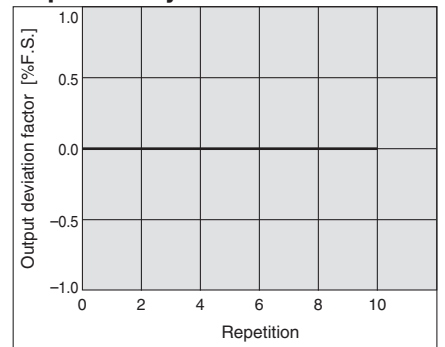

### Pressure characteristics Set pressure: 0.05 MPa

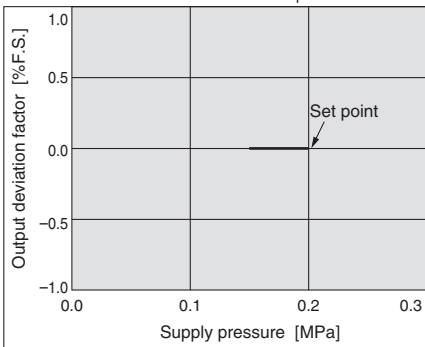

### Flow characteristics Supply pressure: 0.2 MPa

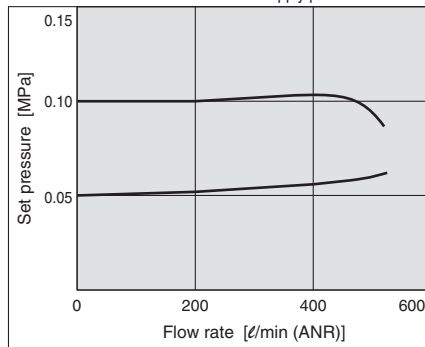

### Relief flow characteristics Supply pressure: 0.2 MPa

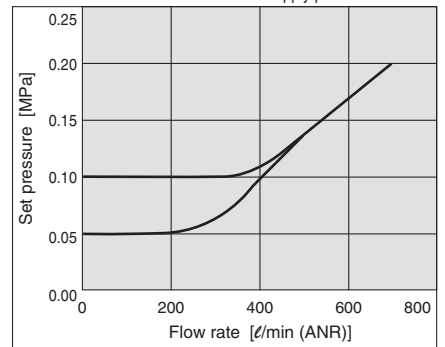

# Series ITV1000/2000/3000

## Series ITV103

### Linearity

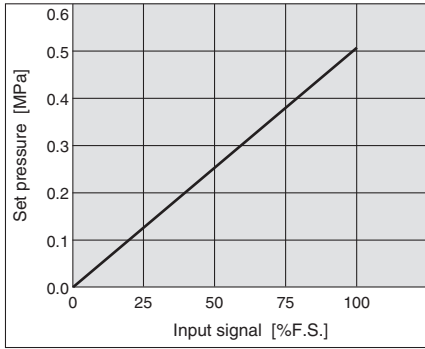

### Hysteresis

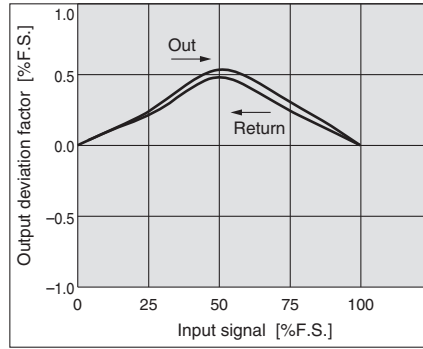

### Repeatability

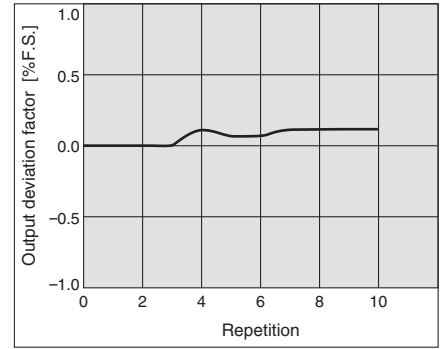

### Pressure characteristics Set pressure: 0.2 MPa

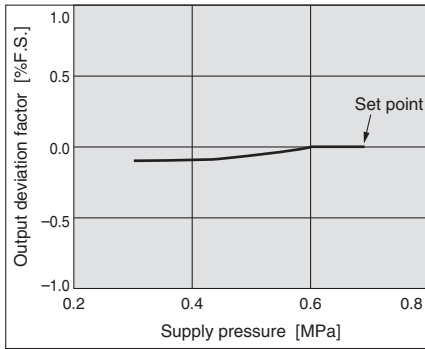

### Flow characteristics Supply pressure: 0.7 MPa

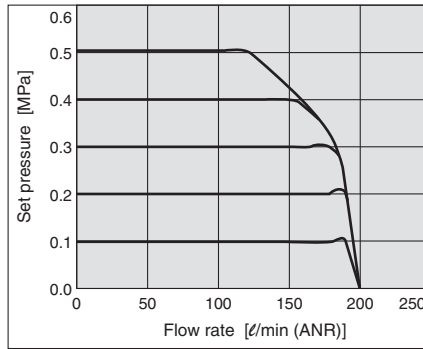

### Relief flow characteristics Supply pressure: 0.7 MPa

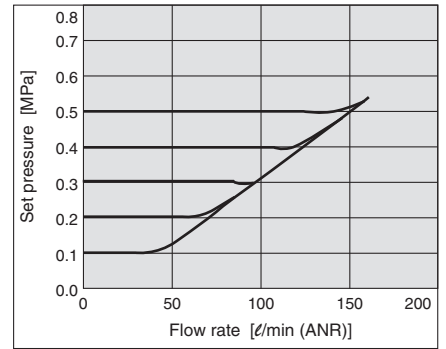

## Series ITV203

### Linearity

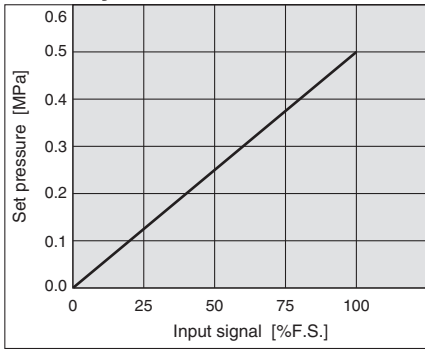

### Hysteresis

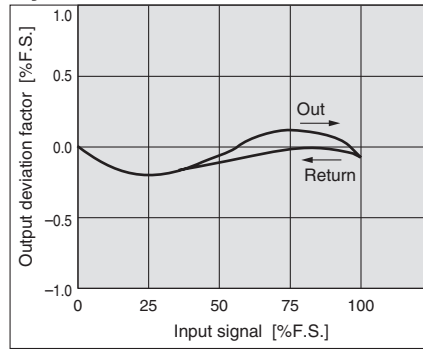

### Repeatability

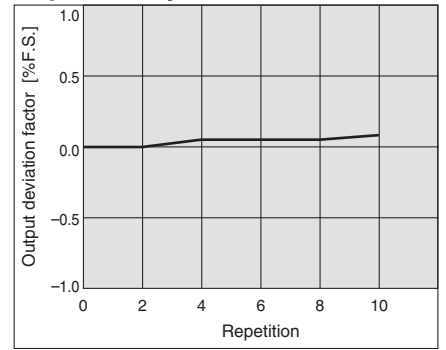

### Pressure characteristics Set pressure: 0.2 MPa

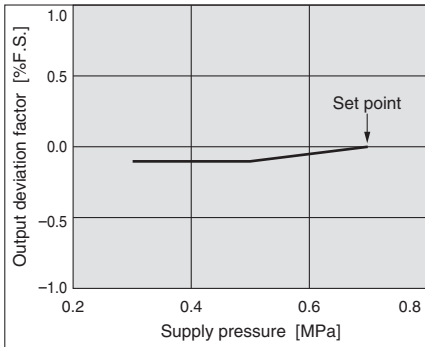

### Flow characteristics Supply pressure: 0.7 MPa

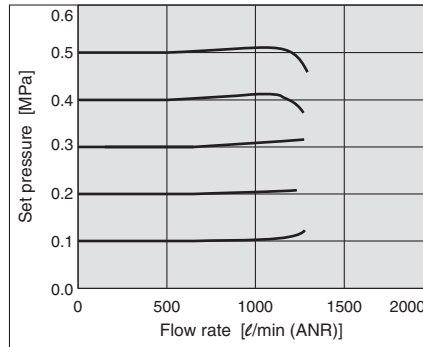

### Relief flow characteristics Supply pressure: 0.7 MPa

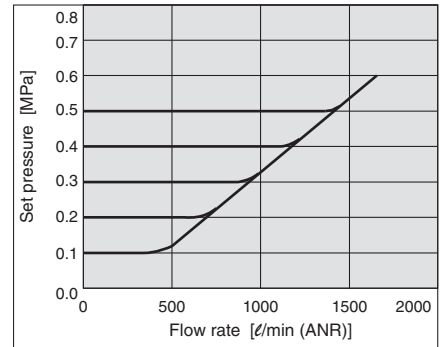



# Series ITV1000/2000/3000

## Series ITV105

### Linearity

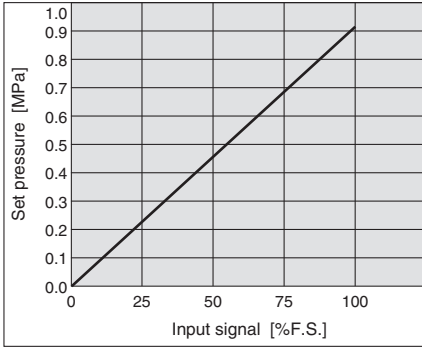

### Hysteresis

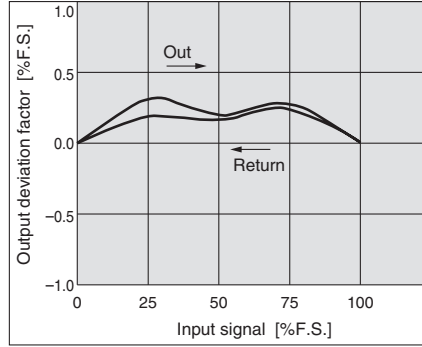

### Repeatability

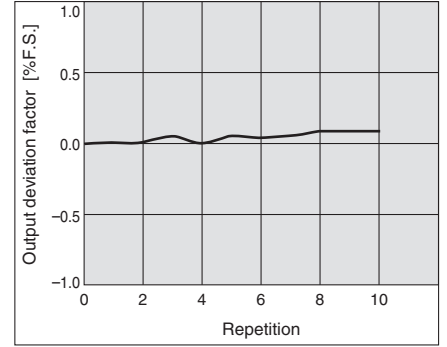

### Pressure characteristics Set pressure: 0.4 MPa

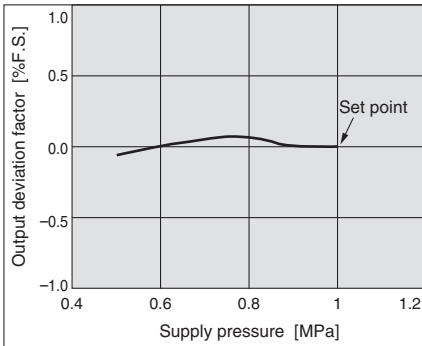

### Flow characteristics Supply pressure: 1.0 MPa

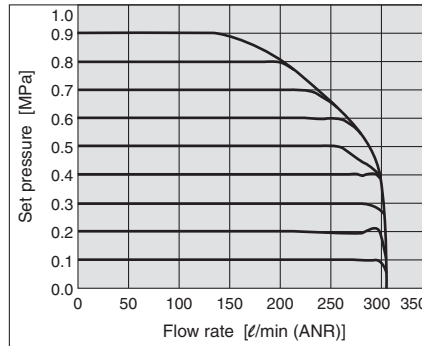

### Relief flow characteristics Supply pressure: 1.0 MPa

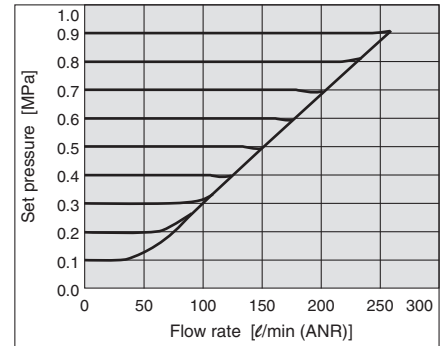

## Series ITV205

### Linearity

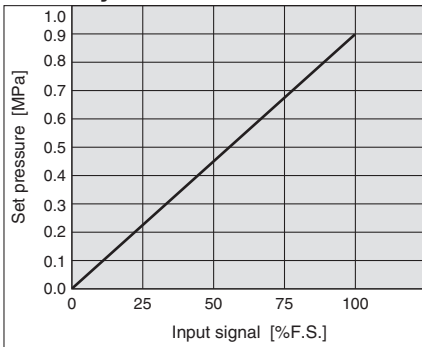

### Hysteresis

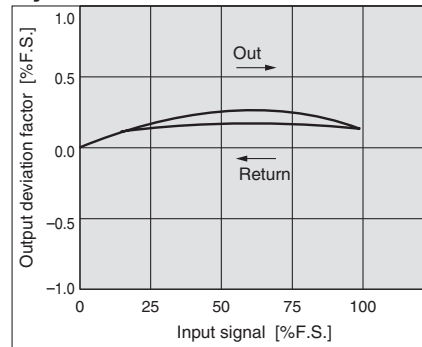

### Repeatability

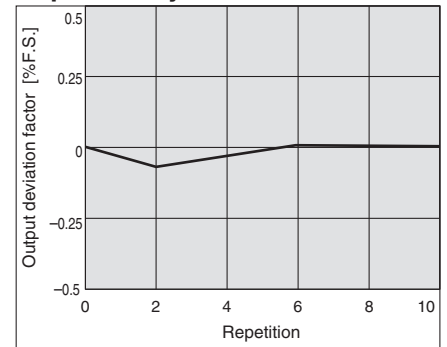

### Pressure characteristics Set pressure: 0.4 MPa

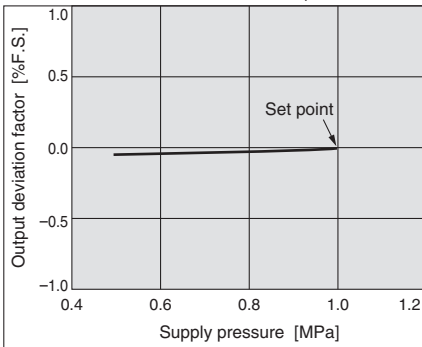

### Flow characteristics Supply pressure: 1.0 MPa

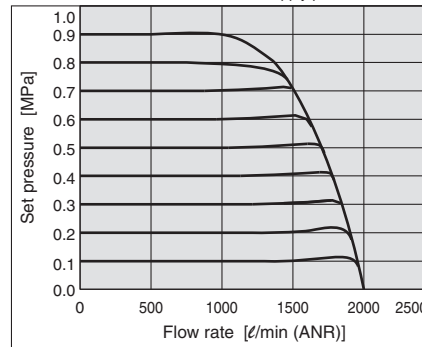

### Relief flow characteristics Supply pressure: 1.0 MPa

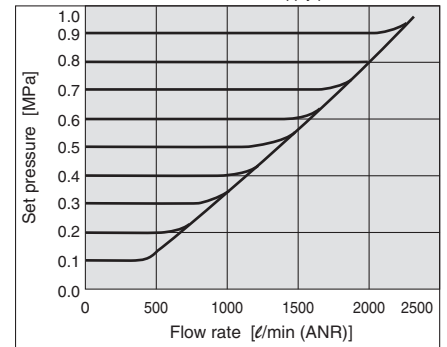

# Series ITV1000/2000/3000

## Dimensions

ITV20□□

Flat bracket

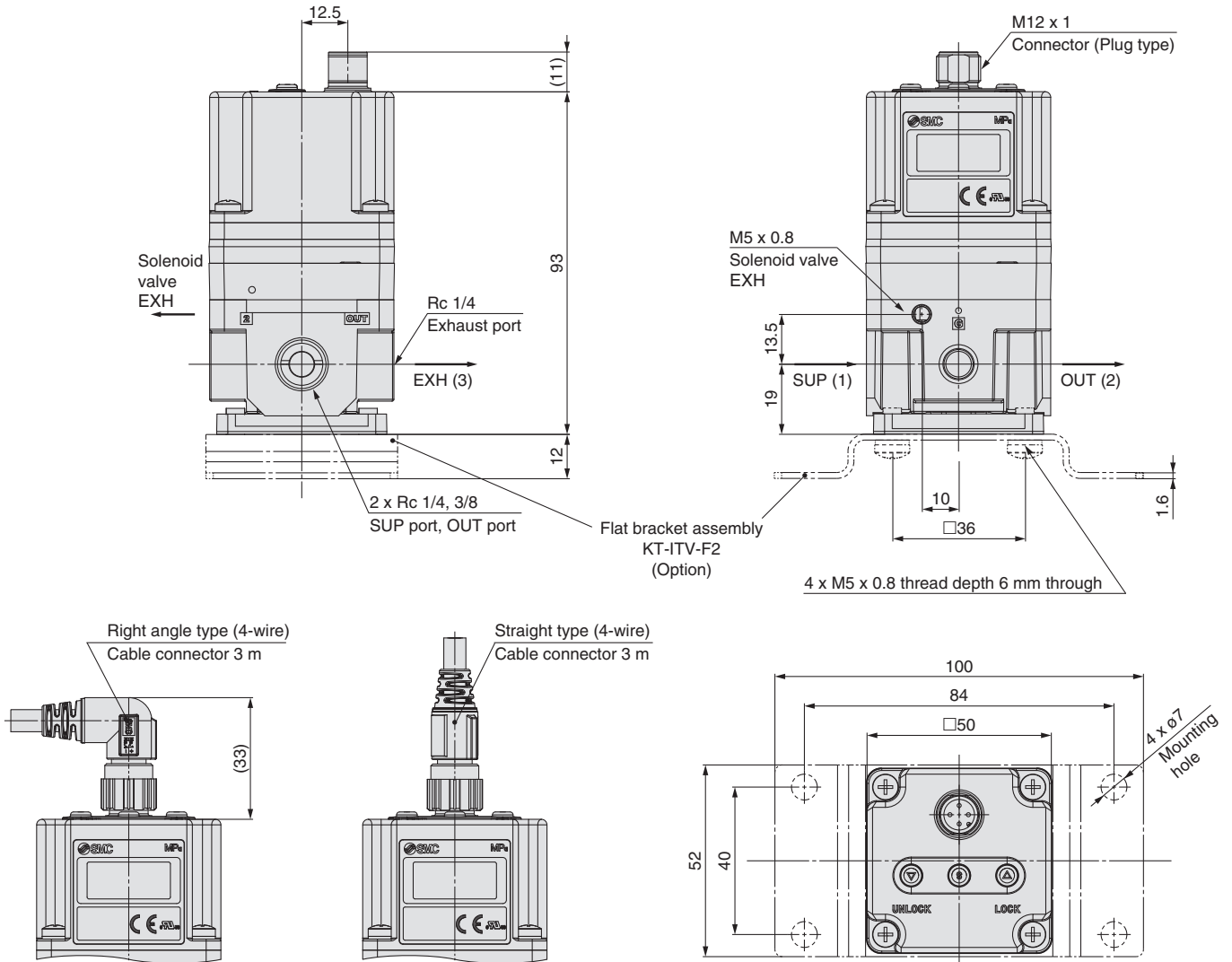

Note) Do not attempt to rotate, as the cable connector does not turn.

L-bracket

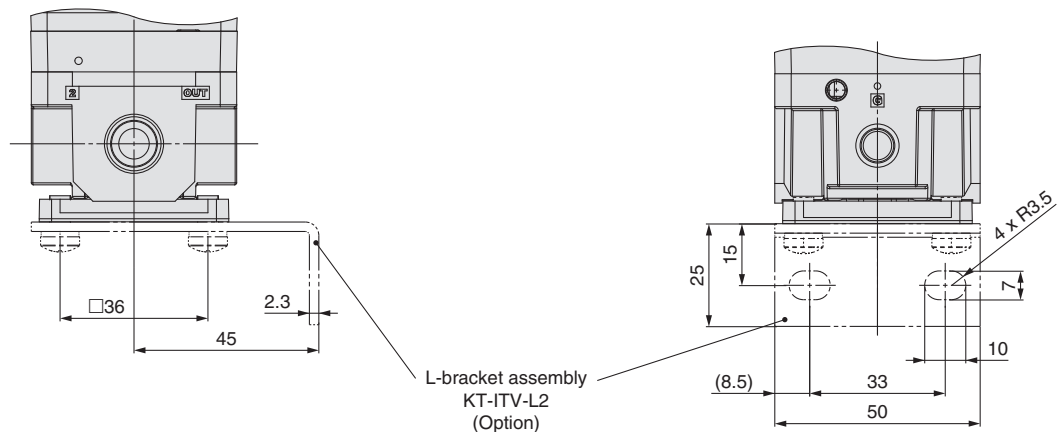

# Made to Order Specifications 3

Please contact SMC for detailed dimensions, specifications and lead times.



## 7 High-Speed Response Time Type

Pressure response with no load is approx. 0.1 sec.

**ITV 2 0 1 0 - 0 1 [ ] 2 [ ] S [ ] - X88**

**Model**

1	1000 type
2	2000 type

**Pressure range**

1	0.1 MPa
3	0.5 MPa
5	0.9 MPa

**Power supply voltage**

0	24 VDC
1	12 to 15 VDC

**Input signal**

0	Current type 4 to 20 mA DC (Sink type)
1	Current type 0 to 20 mA DC (Sink type)
2	Voltage type 0 to 5 VDC
3	Voltage type 0 to 10 VDC

**Monitor output**

1	Analogue output 1 to 5 VDC
2	Switch output/NPN output
3	Switch output/PNP output
4	Analogue output 4 to 20 mA DC (sink type)

**Thread type**

—	Rc
N	NPT
T	NPTF
F	G

**Pressure display unit**

—	MPa
2*	kgf/cm <sup>2</sup>
3	bar
4*	psi
5	kPa

\* Under Japan's new Measurement Act, this is only for overseas sales (SI units are to be used inside Japan).

**Cable connector type**

S	Straight type 3 m
L	Right angle type 3 m
N	Without cable connector

**Bracket**

—	Without bracket
B	Flat bracket
C	L-bracket

**Port size**

1	1/8 (1000 type)
2	1/4 (1000, 2000 type)
3	3/8 (2000 type)

## 8 Manifold Specifications (Except Series ITV3000)

2 through 8 station manifold.

### How to Order Manifolds

**IITV20 - [ ] 02 - 5**

ITV1000, 2000

**Connection thread type**

—	Rc
N	NPT
F	NPTF

**Stations**

2	2 stations
...	...
8	8 stations

**OUT port size**

02	1/4
03	3/8

### How to Order Manifold Mounted

ITV 1 0 [ ] [ ] - [ ] [ ] 1 [ ] [ ] - X26  
 ITV 2 0 [ ] [ ] - [ ] [ ] 2 [ ] [ ] - X26

- Note 1) [ ] in part number is the same model no. for the standard products.
- Note 2) For communication models, consult SMC for availability.
- Note 3) The thread type is Rc only.
- Note 4) For Series ITV1000, the port size is 1/8 only.
- Note 5) For Series ITV2000, the port size is 1/4 only.
- Note 6) The bracket accessory can not be selected.
- Note 7) Not applicable to Series ITV3000

IITV20-02-3 .....1 set (3 station manifold base part no.)  
 \*ITV1030-311S-X26 .....1 set (Electro-pneumatic regulator part no.) Note 2)  
 \*P398020-13 .....1 set (Blanking plate assembly part no.)  
 \*ITV2050-212S-X26 .....1 set (Electro-pneumatic regulator part no.) Note 2)

→ The \* is the symbol for mounting. Add the \* symbol at the beginning of part numbers for electro-pneumatic regulators, etc. to be mounted on the base.

Note) Refer to the table below for possible mixed combination.

Model	ITV101[ ]	ITV103[ ]	ITV105[ ]	ITV201[ ]	ITV203[ ]	ITV205[ ]
ITV101[ ]	●	—	—	●	—	—
ITV103[ ]	—	●	●	—	●	●
ITV105[ ]	—	●	●	—	●	●
ITV201[ ]	●	—	—	●	—	—
ITV203[ ]	—	●	●	—	●	●
ITV205[ ]	—	●	●	—	●	●

### How to Order Manifold Assemblies

#### Example

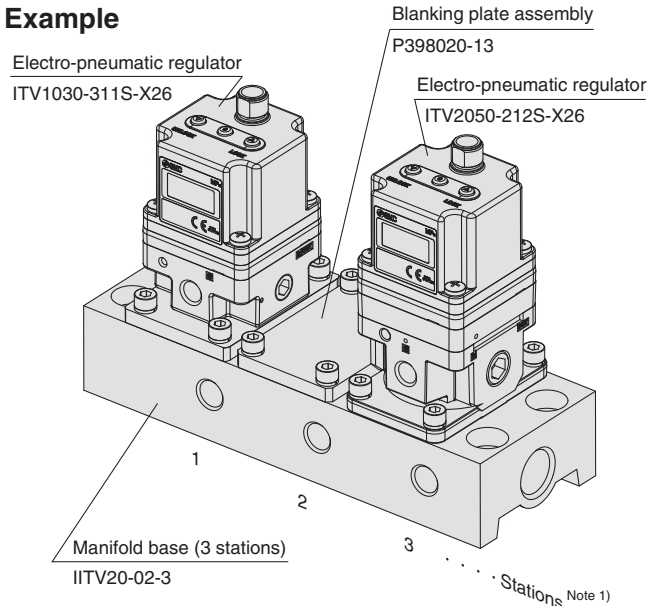

- Note 1) Electro-pneumatic regulators are counted starting from station 1 on the left side with the OUT ports in front.
- Note 2) The port size for mounted electro-pneumatic regulators is Rc 1/8 (ITV1000), Rc 1/4 (ITV2000) only.
- Note 3) When there is a large number of stations, use piping with the largest possible inside diameter for the supply side, such as steel piping.
- Note 4) The use of the straight type cable connector is recommended. To mount right angle type, be certain to check that no possible interference occurs.
- Note 5) When mounting a blanking plate and the regulator with different pressure set, please inform SMC of the order of a manifold station beside a purchase order.



# Series ITV0000/1000/2000/3000 Specific Product Precautions 1

Be sure to read before handling. Refer to back page for Safety Instructions, "Handling Precautions for SMC Products" (M-E03-3) for Common Precautions.

## Series ITV0000/009 □ Precautions

### Air Supply

#### ⚠ Caution

1. Install an air filter near this product on the supply side. Select a filtration degree of 5 μm or less.
2. Compressed air containing large amounts of drainage can cause malfunction of this product and other pneumatic equipment. As a countermeasure, install an aftercooler, air dryer or Drain Catch, etc.
3. If large amounts of carbon dust are generated by the compressor, it can accumulate inside this product and cause malfunction.

For details on the above compressed air quality, refer to SMC's "Air Preparation Systems".

### Wiring

#### ⚠ Caution

Connect the cable to the connector on the body with the wiring arranged as shown below. Proceed carefully, as incorrect wiring can cause damage.

Further, use DC power with sufficient capacity and a low ripple.

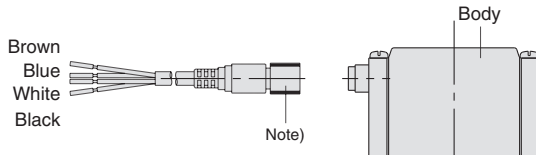

Terminal No.	1	2	3	4
Lead wire colour	Brown	White	Blue	Black
Wiring	Power	Signal	COM	Monitor

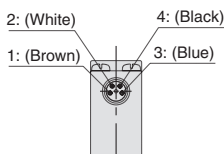

Note) A right angle type cable is also available. The entry direction for the right angle type connector is to downwards (SUP port side). Never turn the connector as it is not designed to turn. Using force to turn the connector will damage the connector coupling.

#### Wiring Diagrams

##### Current signal type

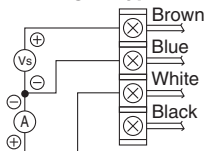

Vs: Power Supply 24 VDC ±10%  
12 to 15 VDC  
A : Input signals 4 to 20 mA DC  
0 to 20 mA DC

##### Voltage signal type

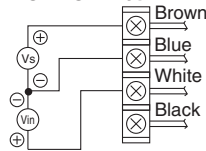

Vs : Power Supply 24 VDC ±10%  
12 to 15 VDC  
Vin: Input signals 0 to 5 VDC  
0 to 10 VDC

#### Monitor output wiring diagram

##### Analogue output, voltage type

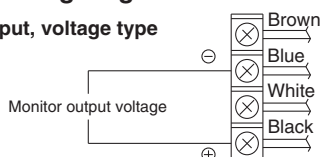

### Handling

#### ⚠ Caution

1. Do not use a lubricator on the supply side of this product, as this can cause malfunction. When lubrication of terminal equipment is necessary, connect a lubricator on the output side of this equipment.
2. If electric power is shut off while pressure is being applied, pressure will be retained on the output side.  
However, this output pressure is held only temporarily and is not guaranteed. If exhausting of this pressure is desired, shut off the power after reducing the set pressure, and discharge the air using a residual pressure exhaust valve, etc.
3. If power to this product is cut off due to a power failure, etc. when it is in a controlled state, output pressure will be retained temporarily. Handle carefully when operating with output pressure released to the atmosphere, as air will continue to flow out.
4. If supply pressure to this product is interrupted while the power is still on, the internal solenoid valve will continue to operate and a humming noise may be generated.  
Since the life of the product may be shortened, shut off the power supply also when supply pressure is shut off.
5. This product is adjusted for each specification at the time of shipment from the factory. Avoid careless disassembly or removal of parts, as this can lead to malfunction.
6. The optional cable connector is a 4 wire type. When the monitor output ( output or switch output) is not being used, keep it from touching the other wires as this can cause malfunction.
7. Please note that the right angle cable does not rotate and is limited to only one entry direction.
8. Take the following steps to avoid malfunction due to noise.
  - 1) Remove power supply noise during operation by installing a line filter, etc. in the AC power line.
  - 2) For avoiding the influence of noise or static electricity, install this product and its wiring as far as possible from strong electric fields such as those of motors and power lines, etc.
  - 3) Be sure to implement protective measures against load surge for induction loads (solenoid valves, relays, etc.).
9. The product characteristics are confined to the static state. When air is consumed on the output side, and especially used in the system with large leakage, pressure cannot approach the set pressure and the service life is drastically shortened with a humming noise of the solenoid valve.
10. For details on the handling of this product, refer to the instruction manual which is included with the product.
11. In locations where the body is exposed to water, dust, etc., there is a possibility that moisture or dust could enter the body through the breathing hole.  
Mount a fitting and tube (M-3AU-3 fitting and TIU01m-mm tube recommended) onto the breathing hole and run the tube to a location not exposed to moisture or dust, etc.

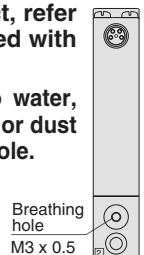

12. If this product will be used in a sealed environment, such as inside an inspection box, a ventilation fan should be installed to ensure adequate ventilation as this product can generate heat in some operating conditions.  
When the power is turned on, a noise may be generated as a means of checking the operating condition of the solenoid valve. This noise is normal and does not indicate a fault.



# Series ITV0000/1000/2000/3000 Specific Product Precautions 4

Be sure to read before handling. Refer to back page for Safety Instructions, "Handling Precautions for SMC Products" (M-E03-3) for Common Precautions.

## Series ITV1000/2000/3000/209 □ Precautions

### Wiring

#### Caution

Connect the cable to the connector on the body with the wiring arranged as shown below. Proceed carefully, as incorrect wiring can cause damage. Further, use DC power with sufficient capacity and a low ripple.

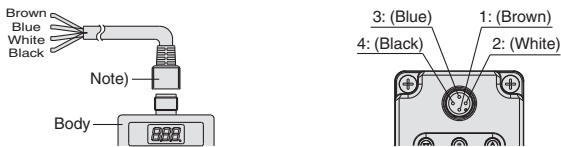

#### Current Signal Type Voltage Signal Type

1	Brown	Power supply
2	White	Input signal
3	Blue	GND (COMMON)
4	Black	Monitor output

#### Preset Input Type

1	Brown	Power supply
2	White	Input signal 1
3	Blue	GND (COMMON)
4	Black	Input signal 2

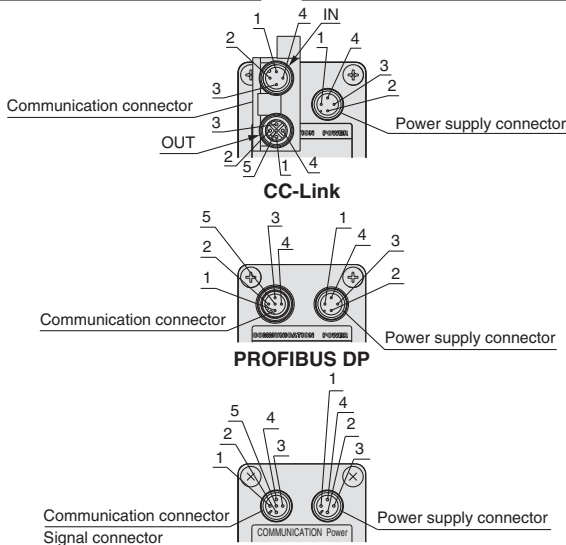

#### DeviceNet™, RS-232C, 16 points preset

Pin No.	IN/OUT communication connector				Signal connector
	CC-Link	DeviceNet™	PROFIBUS DP	RS-232C	16 points preset
1	SLD [-]	DRAIN [-]	No connection	No connection	Input signal 1 [Brown]
2	DB [White]	V+ [Red]	RxD/TxD-N [Green]	TxD [White]	Input signal 2 [White]
3	DG [Yellow]	V- [Black]	No connection	RxD [Blue]	Input signal 3 [Blue]
4	DA [Blue]	CAN_H [White]	RxD/TxD-P [Red]	GND [Black]	Input signal 4 [Black]
5	No connection	CAN_L [Blue]	No connection	No connection	Common [Grey]

Pin No.	Power supply connector				
	CC-Link	DeviceNet™	PROFIBUS DP	RS-232C	16 points preset
1 [Brown]	Vcc	Vcc	Vcc	Vcc	Vcc
2 [White]	FG	Can not connect	FG	No connection	No connection
3 [Blue]	GND	GND	GND	GND	GND
4 [Black]	No connection	Can not connect	No connection	FG	Monitor output

Note 1) The indicated wire colours are when a cable connector made by SMC is used.  
 Note 2) The cable is also available in a right angle type. (Communication cable: straight type only)  
 A right angle type connector is attached facing left (towards the SUP port). On communication models, the connector faces backwards (towards the EXH port). Do not attempt to rotate, as the connector does not turn.

■ **Trademark Information**  
 DeviceNet™ is a trademark of ODVA.

**Knock-down connectors** \* Order separately.

Part number	CC-Link compatibility		DeviceNet™ compatibility		PROFIBUS DP compatibility			
	Plug	Socket	Plug	Socket	Terminal Plug	Plug	Socket	
	PCA-1557617	PCA-1557620	PCA-1557659	PCA-1557662	PCA-1557675	PCA-1557701	PCA-1557714	PCA-1557727

#### Wiring diagram

##### Current signal type

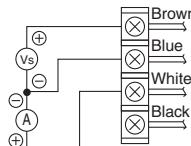

Vs : Power supply 24 VDC  
 12 to 15 VDC  
 A : Input signal 4 to 20 mA DC  
 0 to 20 mA DC

##### Voltage signal type

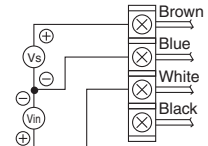

Vs : Power supply 24 VDC  
 12 to 15 VDC  
 Vin : Input signal 0 to 5 VDC  
 0 to 10 VDC

##### 4 points preset input type

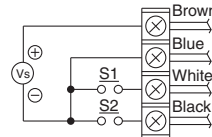

Vs : Power supply 24 VDC  
 12 to 15 VDC  
 (Negative common)

##### 16 points preset input type

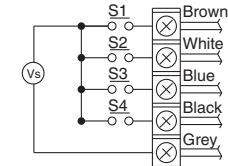

Vs : Power supply 24 VDC (No polarity)

One of the preset pressures P1 through P4 is selected by the ON/OFF combination of S1 and S2.

S1	OFF	ON	OFF	ON	OFF	ON	OFF	ON	OFF	ON
S2	OFF	OFF	ON	ON	OFF	ON	OFF	ON	OFF	ON
S3	OFF	OFF	OFF	OFF	ON	ON	OFF	ON	OFF	ON
S4	OFF	OFF	OFF	OFF	OFF	ON	OFF	ON	OFF	ON
Preset pressure	P01	P02	P03	P04	P05	...	P14	P15	P16	

\* For safety reasons, it is recommended that one of the preset pressures be set to 0 MPa.

\* Preset pressures are set based on the minimum unit for output display.

MPa	kgf/cm <sup>2</sup>	bar	psi	kPa
0.001	0.01	0.01	0.1	1

· Note that this is 1 psi for 130 psi types.

##### 10 bit digital input type

Wire Colour	Signal name
Pink-Black 2	Power supply (24 VDC)
Green-Black 2	Power supply (GND)
Blue	Signal Common (No Polarity)
Blue-Black 2	MSB 10 bit
Grey-Black 1	9 bit
Orange-Black 1	8 bit
Green-Black 1	7 bit
Pink-Black 1	6 bit
Blue-Black 1	5 bit
Grey	4 bit
Orange	3 bit
Green	2 bit
Pink	LSB 1 bit

Note) The wire colour is shown for when an option cable is used.

# Z30A

## Force transducers

### Special features

- Tensile/compressive force transducer with maximum accuracy
- Nominal (rated) forces 50 N... 10 kN
- Class 00 with DKD calibration certificate to ISO 376
- High long-term stability
- Overload protection at nominal (rated) force  $\leq 1000$  N
- TEDS (Transducer Electronic Data Sheet)

Data sheet



Z30A/50 N ... 1000 N

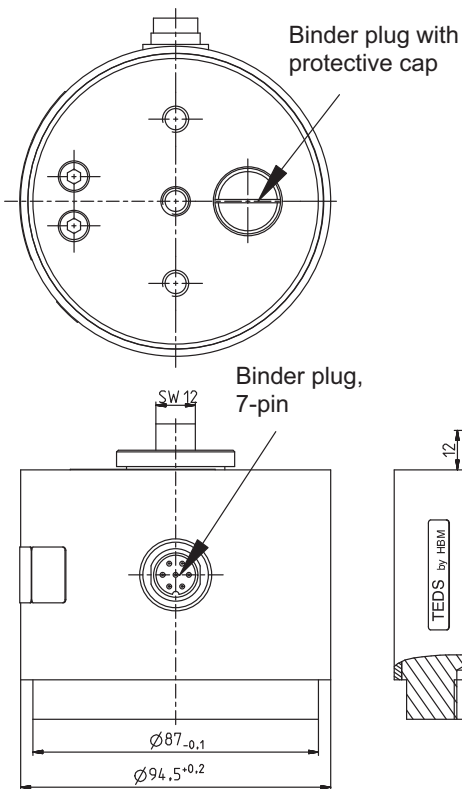

Z30A/2 kN ... 10 kN

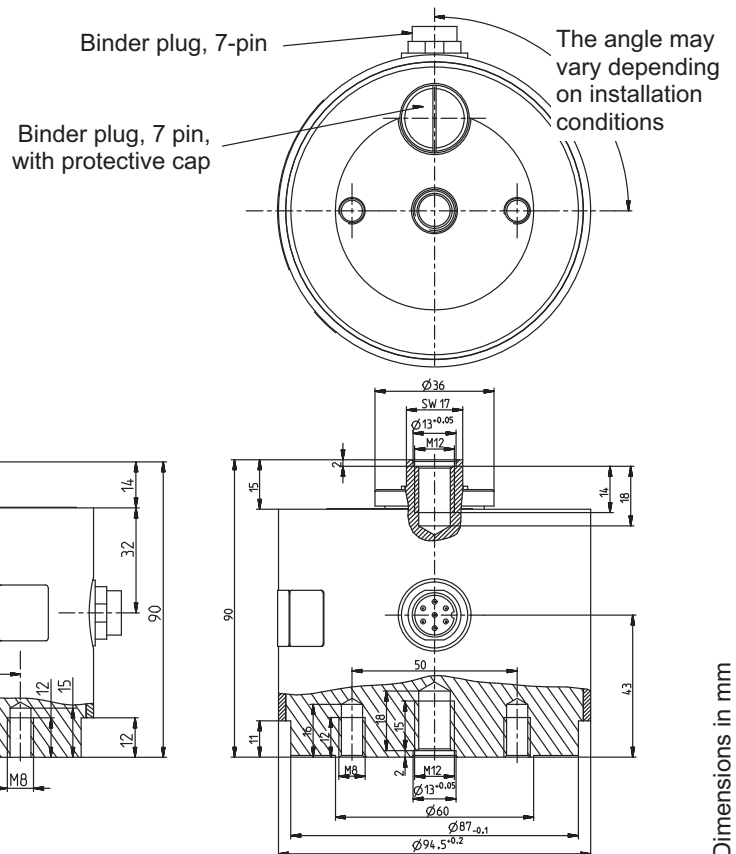

# Specifications

Nominal (rated) force	$F_{nom}$	N	50	100	200	500	1000			
		kN						2	5	10
<b>Accuracy values per ISO376</b>										
Accuracy information in accordance with ISO376 in the force range of 20 % to 100 %			00 <sup>1)</sup>							
Rel. reproducibility and repeatability errors (0.2 $F_{nom}$ to $F_{nom}$ ) For a constant mounting position	b'	%	<±0.02							
For a changing mounting position	b		<±0.04							
Rel. deviation from the fitting curve (0.2 $F_{nom}$ to $F_{nom}$ )	$f_c$		<±0.02							
Rel. zero error (zero signal return)	$f_o$		<±0.008							
Rel. reversibility error (0.2 $F_{nom}$ to $F_{nom}$ )	v		<±0.06							
Rel. Non-linearity	$d_{lin}$		<±0.03							
Temperature coefficient of sensitivity	$TC_S$		% / 10K	<±0.02						
Temperature coefficient of zero signal	$TC_0$	<±0.02								
Rel. creep over 30 mins.	$d_{crF+E}$	%	<±0.03							
Effect of lateral forces (lateral force 10% $F_{nom}$ )	$d_Q$	%	<±0.03							
Effect of eccentricity per mm	$d_E$		< 0.03							
<b>Rated electrical output</b>										
Nominal (rated) output	$C_{nom}$	mV/V	2							
Rel. sensitivity error (pressure)	$d_c$	%	<±0.1							
Rel. rated output variation (tension/compression)	$d_{zd}$	%	<±0.1							
Rel. zero signal deviation	$d_{s,o}$	mV/V	<±0.2	<±0.1						
Input resistance	$R_e$	Ω	>345				>690			
Output resistance	$R_a$		300 ... 500				600 ... 800			
Insulation resistance	$R_{is}$		>5·10 <sup>9</sup>							
Reference excitation voltage	$U_{ref}$	V	5							
Operating range of the excitation voltage	$B_{U,G}$		0.5 ... 12							
<b>Temperature</b>										
Reference temperature	$t_{ref}$	°C	+22							
Nominal (rated) temperature range	$B_{t,nom}$		+10 ... +40							
Operating temperature range	$B_{t,G}$		-10 ... +70							
Storage temperature range	$B_{t,S}$		-25 ... +85							
<b>Characteristic mechanical quantities</b>										
Max. operating force	$F_G$	%	120				150			
Force limit	$F_L$		150							
Breaking force	$F_B$		250							
Static lateral force limit	$F_Q$		100	75	35	100	90	40		
Torque limit	$M_G$	N·m	1.5	3	5	5	5	80		
Nominal (rated) displacement	$S_{nom}$	mm	< 0.4				approx. 0.2			
Fundamental frequency	$f_G$	kHz	0.2	0.3	0.5	0.9	1.1	1.1	1.1	1.25
Rel. permissible oscillation stress	$F_{rb}$	%	70							
<b>General information</b>										
Degree of protection in accordance with EN 60529			IP50							
Plug connection, 6-wire configuration			Binder series 723, radial and axial housing plug							
Transducer identification			TEDS, per IEEE 1451.4							
Weight		kg	approx. 0.9				approx. 2.3			

<sup>1)</sup> Classification only guaranteed in conjunction with a DKD calibration certificate to ISO 376.

## Force transducer ordering numbers

Ordering code	Nominal (rated) force							Unit	
	1-Z30A/...	50	100	200	500	1000			
						2	5	10	kN

Ordering example: 1-Z30A/2kN

## Accessories (not included in the scope of supply)

### Force application parts for tensile loading

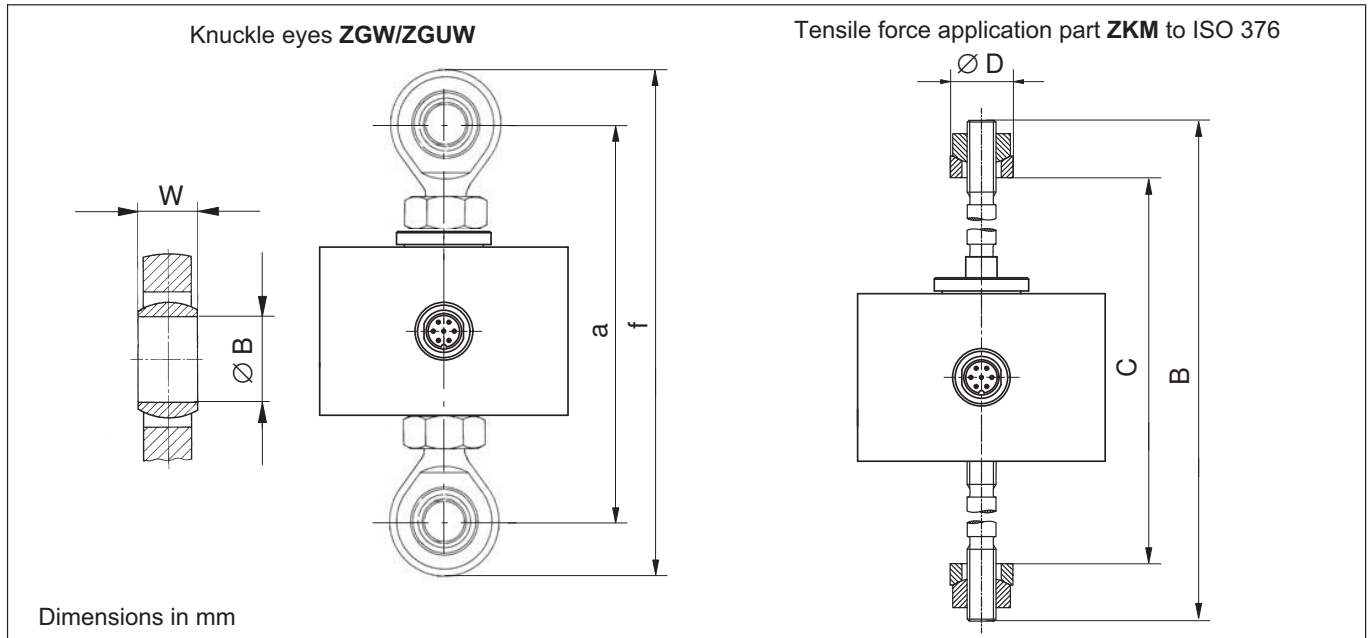

Type	ZKM Ordering number	B	C		Ø D
			min	max	
Z30A/2kN-10kN	1-Z30/10kN/ZKM	229	250	312	35 <sup>-0.120.</sup> <sub>-0.280</sub>

Type	Upper/lower knuckle eye Ordering number	a	f	W	Ø B
Z30A/50N-1000N	1-U1R/200kg/ZGW	138	170	12	8 <sup>H7</sup>
Z30A/2kN-10kN	1-U2A/1t/ZGUW	169	201	16	12 <sup>H7</sup>

### Load button for compressive loading

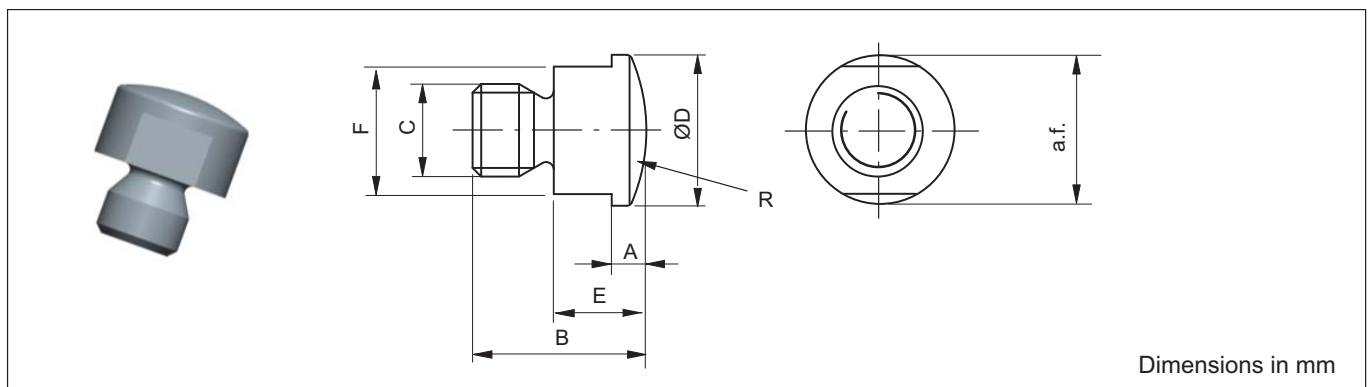

Type	Load button Ordering number	A	B	C	Ø D <sup>-0.05.</sup> <sub>-0.10</sub>	E	F	R	a.f.
Z30A/50N-1000N	1-U1R/200kg/ZL	3	15	M8	13	8	11	16	11
Z30A/2kN-10kN	3-9202.0140	3	20	M12	20	9	17	40	17



### Thrust piece EDO4/EDO3 for precision measurements

always use together with the load button for compressive loads

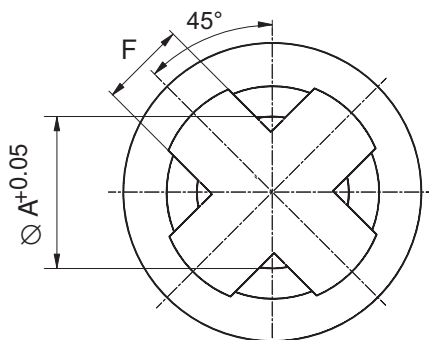

View from below

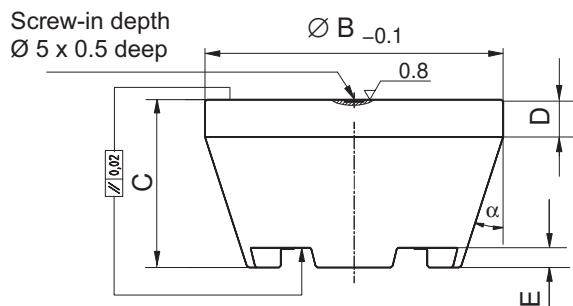

Dimensions in mm

Type	Thrust piece Ordering number	Weight (kg)	Ø A	Ø B	C	D	E	F	α
Z30A/50N-1000N	1-EDO3/1kN	approx. 0.2	13.2	37	22	6	3	8	18°
Z30A/2kN-10kN	1-EDO4/50kN	0.34	20.2	48	29	8	5	12	18°

### Pin assignment of plug and connection cable KAB139A-6

<p>Cable shield connected to housing</p>	wh (white)	Measurement signal (+) U <sub>A</sub>	1	<p>Binder series 723</p>
	bk (black)	Bridge excitation voltage (-) U <sub>B</sub> (TEDS)	2	
	rd (red)	Measurement signal (-) U <sub>A</sub>	4	
	bu (blue)	Bridge excitation voltage (+) U <sub>B</sub>	3	
	gn (green)	Sense lead (+)	6	
	gy (gray)	Sense line (-) (TEDS)	7	



Shipping case for 4 Z30A force transducers and accessories, ordering number: 1-Z30/BOX

Dimensions: 440 x 320 x 147

### Cables/plugs

Ordering number	
1-KAB139A-6	Connection cable Kab139A-6, 6 m, with binder female cable connector and free ends
K-CAB-F	Cable, configurable with different plugs and lengths

Subject to modifications.  
All product descriptions are for general information only. They are not to be understood as a guarantee of quality or durability.

**Hottinger Brüel & Kjaer GmbH**  
Im Tiefen See 45 · 64293 Darmstadt · Germany  
Tel. +49 6151 803-0 · Fax +49 6151 803-9100  
Email: info@hbm.com · www.hbm.com

measure and predict with confidence



## BM40, BM40PB, BM40IE Industrial amplifier

### Special features

- Freely configurable measurement channel with TEDS channel parameterization
- Connection of 7 transducer technologies with 19.2 kHz sample rate
- Accuracy class up to 0.01 with 32-bit A/D conversion
- 4 digital I/Os and 1 analog output (voltage/current reversible)
- Modular connectivity for up to 6 modules by ClipX bus with transfer of measured values
- Internal calculation channels (Smart functions)
- OPC UA, PPMP protocol, PROFINET® (IRT/RT), EtherCAT®, EtherNet/IP™, PROFIBUS® (DPV1), Modbus TCP
- Simple operation via integrated web server with 3 levels of user guidance
- Rugged and compact metal housing for attachment to DIN rail



### Block diagram

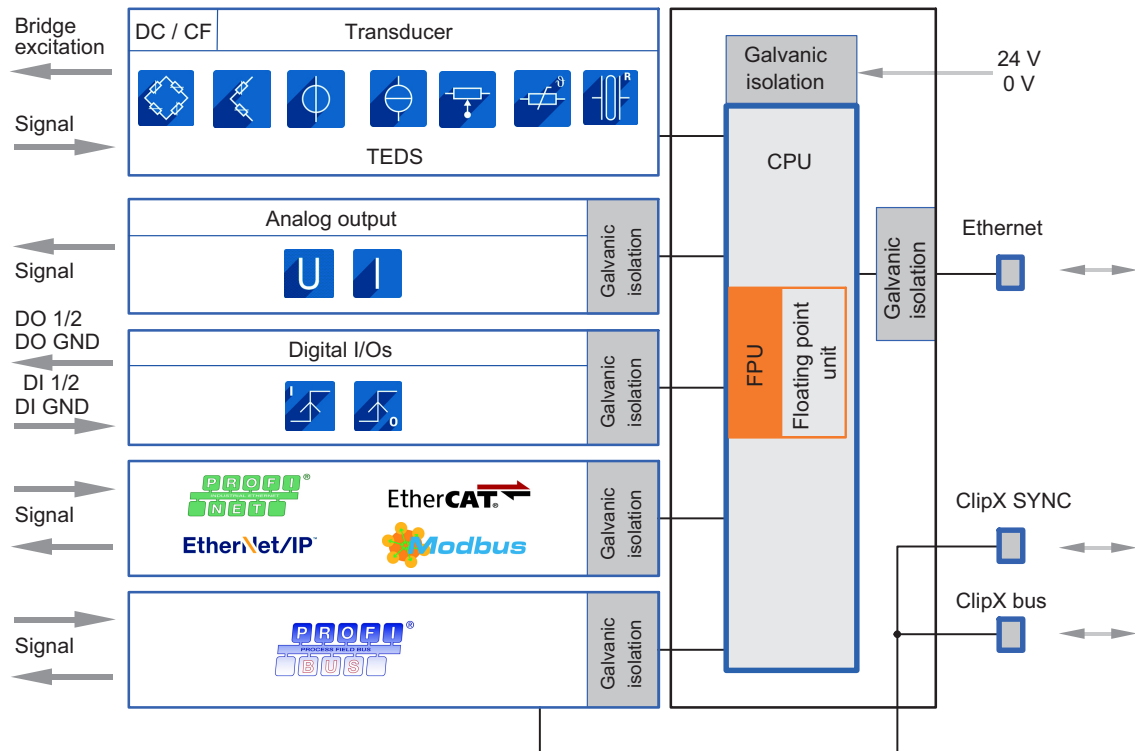

## Specifications for ClipX

General specifications		BM40, BM40PB, BM40IE
Measurement input	Number	1, galvanically isolated to supply
Transducer technologies		Full and half bridge strain gages, piezoresistive sensors (voltage-fed), potentiometric transducers, resistance thermometers (Pt100), electric voltage ( $\pm 10$ V), electric current ( $\pm 20$ mA)
A/D conversion	bit	32, delta-sigma converter
Sample rate	S/s	19200
Signal bandwidth (-3 dB)	Hz	Direct voltage sensor excitation (DC): 3800 Hz when filter off Carrier frequency sensor excitation (CF): 200 Hz
Active low-pass filter	Hz	Bessel or Butterworth 6th order, IIR DC: 0.02 ... 3000; filter OFF (3800) CF: 0.02 ... 200
Transducer identification		TEDS, IEEE 1451.4
Supported variants		Zero-wire TEDS and 1-Wire TEDS
TEDS module spacing, max.	m	100
Supply voltage range	V <sub>DC</sub>	10 ... 30 (nominal (rated) voltage 24 V)
Supply voltage interruption (based on PLC standard DIN EN 61131-2)		
24 V (-10 %)	ms	10
12 V (-10 %)	ms	1
Power consumption at 24 V supply voltage, max.	W	5
Galvanic isolation	V	60
		Between power supply, sensor input, ClipX bus, analog output, all digital inputs and outputs, as well as fieldbuses apart from PROFIBUS
Fuses		None
Automatic current limiter		For all input and output signals
Short-circuit resistance		Input/output signals, synchronization and fieldbus are short-circuit proof and coding elements can be used to safeguard the connector plugs, so they are not transposed.
Ethernet (data link)		10Base-T / 100Base-TX
Protocol/addressing		TCP/IP (direct IP address or DHCP)
Plug connection		RJ45, 8-pin
Cable type		Standard LAN, CAT5, SFTP
Max. cable length to device	m	100
ClipX bus (data transfer)		
Number of devices, max.		6
Data transfer		1 data value (measured value, calculated value, etc.) with status
Transmission speed	kHz	1, with automatic synchronization
Protocol / addressing		RS485, node 1 ... 6
Cabling		Wires, twisted in pairs and shielded
Distance between 2 modules, max.	cm	30

## Specifications for ClipX (continued)

<p><b>Real time calculation in device</b></p> <p>Calculated Channels Update rate Functions</p>	<p>Number ms</p>	<p>6 1 Matrix calculation (2x2 ... 6x6), 4:1 multiplexer, Tolerance window, Peak with capture, Trigger, Checkweigher, Floating mean value/RMS, Physical work, Bessel and Butterworth filters (IIR), FIR filter, Algebra (+ - * /), Counter, Differentiator, Coordinates transformation (Cartesian ↔ polar), PID controller, Logical function (AND, OR, NAND, NOR, XOR, XNOR, NOT), Signal generator, Pulse-width measurement, Timer, Standstill recognition</p>
<p><b>Peak-value memory</b></p> <p>Number Reference level Response time, typical</p>	<p>μs</p>	<p>3 Min, Max or Peak-to-Peak All measurement signals, all calculation channels, data from ClipX bus, fieldbus and Ethernet, analog output 52</p>
<p><b>Limit switches</b></p> <p>Number Reference level Function Response time, typical</p>	<p>μs</p>	<p>4 All measurement signals, all calculation channels, data from ClipX bus, fieldbus and Ethernet, analog output Exceeding or falling below a level Inside/outside a tolerance band 300</p>
<p><b>Digital inputs</b></p> <p>Number Function Response time, typical</p>	<p>ms</p>	<p>2 Zero, Tare, Reset Limit Value, Digital output, Toggle Parameter Sets (bit-coded), Flags for Calculated Channels 1</p>
<p><b>Digital outputs</b></p> <p>Number Function Response time, typical</p>	<p>ms</p>	<p>2 Designed as high-side switches Limit value, digital input, measured value/system status, fieldbus flag, current parameter set number (bit-coded), calculation channel flags and Ethernet flags 1</p>
<p><b>Parameter Sets</b></p> <p>Number Device "cloning" Switching time</p>		<p>10 Sensor settings, measurement acquisition incl. computation channels, limit values, digital input/output settings, analog output settings. All the device settings can be saved in full to a PC as a backup and reloaded, either with or without Ethernet and fieldbus settings. &lt;100 ms plus settling time of low-pass filter; The measured value status is set to 'invalid' for 2.5 seconds so as to suppress transient responses.</p>

## Specifications for ClipX (continued)

<b>Internal device storage</b> Freely usable Data memory (FIFO)  Additional content	MByte	8  4,000 values of max. 6 signals, measured values, peak values, calculated values, values from fieldbus or Ethernet, from own ClipX or from other ClipX transmitted via ClipX bus.  Own calibration certificate, manufacturer's certificate 2.1 according to EN 10204, device description files for the fieldbuses (BM40IE only); Windows PC software ClipX-Data-Viewer (with scope and data storage function).
<b>Nominal (rated) temperature range</b>	°C	0 ... 50
<b>Storage temperature range</b>	°C	-25 ... +75
<b>Relative humidity</b>	%	5 ... 95 (non-condensing)
<b>Protection class</b> (height up to 2,000 m, degree of pollution 2)		III (as per EN 61140)
<b>Equipment protection level</b>		IP20 (according to EN 60529)
<b>Operating temperature range</b> (no condensation allowed/module not immune to water condensation)	°C	-20 ... +60
<b>Mechanical tests</b> (device off, according to PLC hardware standard EN61131-2) Oscillation (90 min. in each direction)	g	2 (20 m/s <sup>2</sup> ); 8.4 ... 200 Hz (constant acceleration); 5 ... 8.4 Hz (constant amplitude 14 mm)
Impact (3 times in each direction)	g	35 (350 m/s <sup>2</sup> ); sinusoidal; impact duration 6 ms
<b>EMC requirements</b>		Compliance with group 1, class B according to EN 55011 (Emissions). Compliance with criterion B for ESD and surge according to EN 61326-1 (Immunity).
<b>Proof of quality</b>		Manufacturer's certificate 2.1 according to EN 10204 and the HBM factory calibration certificate are stored in the device and can be downloaded from <a href="https://www.hbm.com/ClipX">https://www.hbm.com/ClipX</a> .
<b>Long-term stability</b>		All devices are pre-aged in an oven run to improve long-term stability.
<b>Dimensions, (H x W x D),</b> including DIN rail mounting material	mm	100 x 25 x 118
<b>Weight,</b> , approx.	g	360

<b>Strain gage full bridge</b>		<b>BM40, BM40PB, BM40IE</b>
<b>Accuracy class</b>		0.01
<b>Transducers that can be connected</b>		Full bridge strain gages
<b>Transducer impedance</b>	Ω	80 ... 5000
<b>Measurement ranges (at 5 V bridge excitation)</b>	mV/V	2.5 or 5, reversible
<b>Bridge excitation voltage</b>	V	5 (± 10 %), direct voltage (DC) or carrier frequency (CF) 1200 Hz reversible
<b>Signal bandwidth (-3 dB)</b>	Hz	DC: 0 ... 3800 CF: 0 ... 200
<b>Permissible cable length between ClipX and transducer</b>	m	< 100
<b>Transducer identification</b>		TEDS, IEEE 1451.4; optionally 1-wire technology with separate TEDS module or HBM zero-wire technology with TEDS module in the sense leads of the sensor

## Specifications for ClipX (continued)

<b>Noise (peak-to-peak) at 25 °C, excitation 5 V (DC), 350 Ohm-Full bridge</b>		
With 1 Hz Bessel filter	μV/V	0.04
With 10 Hz Bessel filter	μV/V	0.12
With 100 Hz Bessel filter	μV/V	0.4
With 1 kHz Bessel filter	μV/V	1.2
<b>Noise (peak-to-peak) at 25 °C, excitation 5 V (CF), 350 Ohm-Full bridge</b>		
With 1 Hz Bessel filter	μV/V	0.05
With 10 Hz Bessel filter	μV/V	0.16
With 100 Hz Bessel filter	μV/V	0.5
With 200 Hz Bessel filter	μV/V	0.8
<b>Non-linearity</b>	%	0.005 of full scale value
<b>Zero drift (5 V excitation)</b>	%/10 K	0.01 of full scale value
<b>Full scale drift (5 V excitation)</b>	%/10 K	0.01 of measured value
<b>Full bridge strain gage with Zener barriers</b>		
<b>Accuracy class</b>		
at 80 Ω transducer impedance, 6-wire configuration, max. 100 m cable length and DC or CF		0.2
at 350 Ω transducer impedance, 6-wire configuration, max. 100 m cable length and DC or CF		< 0.05
at 350 Ω ... 5 kΩ transducer impedance, 6-wire configuration, max. 100 m cable length and DC		0.05
<b>Half bridge strain gage</b>		<b>BM40, BM40PB, BM40IE</b>
<b>Accuracy class</b>		0.1
<b>Transducers that can be connected</b>		Strain gage half bridges
<b>Transducer impedance</b>	Ω	80 ... 5000
<b>Measurement ranges (at 5 V bridge excitation)</b>	mV/V	2.5 or 5; reversible
<b>Bridge excitation voltage</b>	V	5 (± 10 %), direct voltage (DC) or carrier frequency (CF) 1200 Hz reversible
<b>Signal bandwidth (-3 dB)</b>	Hz	DC: 0 ... 3800 CF: 0 ... 200
<b>Permissible cable length between ClipX and transducer</b>	m	< 100
<b>Transducer identification</b>		TEDS, IEEE 1451.4; optionally 1-wire technology with separate TEDS module or HBM zero-wire technology with TEDS module in the sense leads of the sensor
<b>Noise (peak-to-peak) at 25 °C, excitation 5 V (DC), 350 Ohm-Half bridge</b>		
With 1 Hz Bessel filter	μV/V	0.08
With 10 Hz Bessel filter	μV/V	0.24
With 100 Hz Bessel filter	μV/V	0.8
With 1 kHz Bessel filter	μV/V	2.4
<b>Noise (peak-to-peak) at 25 °C, excitation 5 V (CF), 350 Ohm-Half bridge</b>		
With 1 Hz Bessel filter	μV/V	0.1
With 10 Hz Bessel filter	μV/V	0.32
With 100 Hz Bessel filter	μV/V	1
With 200 Hz Bessel filter	μV/V	1.6
<b>Non-linearity</b>	%	0.05 of full scale value
<b>Zero drift (5 V excitation)</b>	%/10 K	0.1 of full scale value
<b>Full scale drift (5 V excitation)</b>	%/10 K	0.1 of measured value

## Specifications for ClipX (continued)

### Dimensions

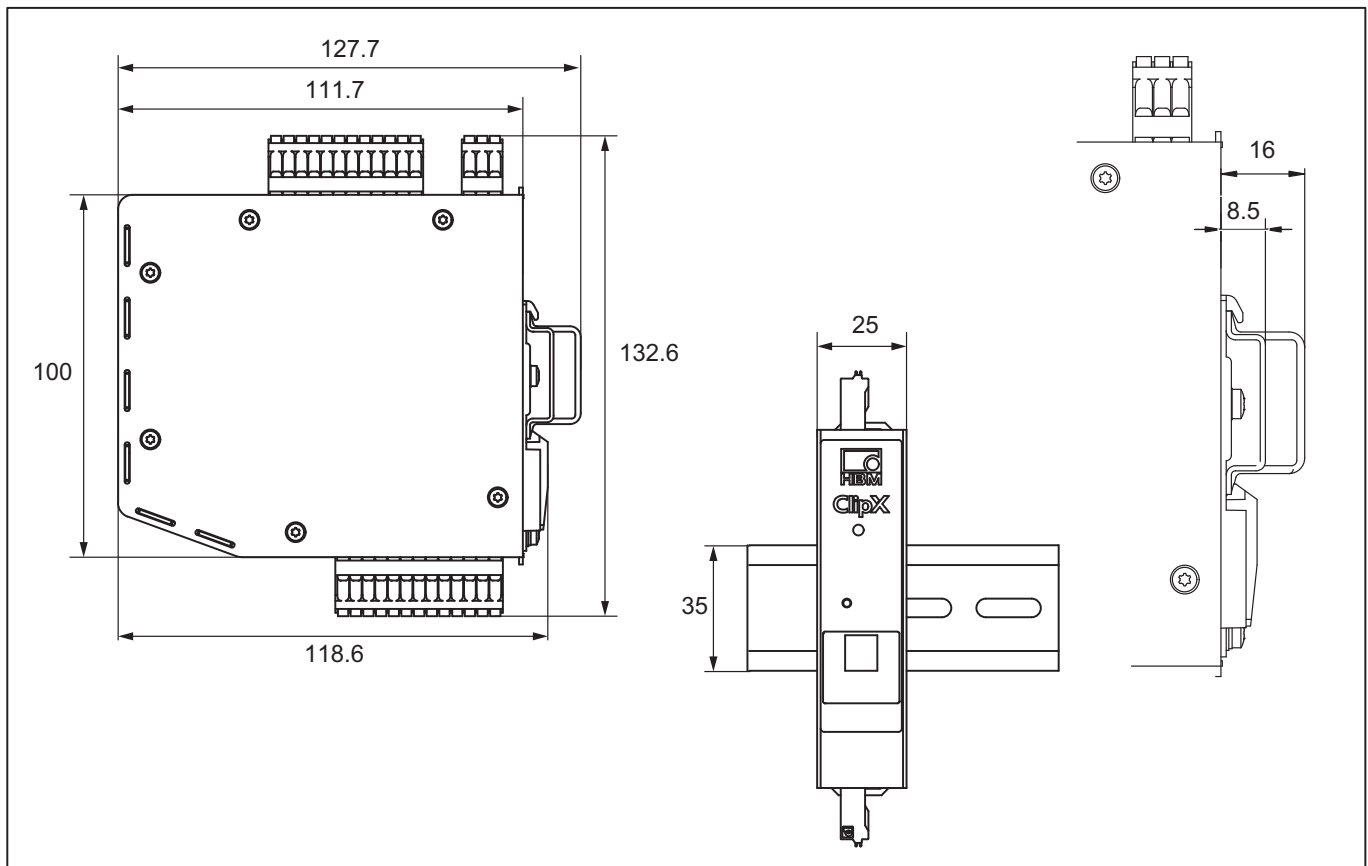

**Note:** ClipX devices can be manually fitted to the DIN rail and removed without the need for tools. To help with construction, ready-prepared ePLAN macros (no license required) and 3D STEP files are available free of charge at <https://www.hbm.com/ClipX>.

### Replacement parts

Accessories	Ordering number
<b>Ethernet cable</b> For direct operation of devices on a PC or laptop, length 2 m, type CAT-5+	1-KAB239-2
<b>ClipX plug set (3x push-in)</b> Three-piece plug terminal set for sensor connection, power supply and analog output, including coding pins	1-CON-S1019
<b>Shield connection clamp ME-SAS MINI - 2200456 from PHOENIX</b> Shield connection clamp for cable strain relief	1-CON-A1023

**Note:** A plug terminal set and a shield connection clamp are included with the delivery

Subject to modifications.  
 All product descriptions are for general information only. They are not to be understood as a guarantee of quality or durability.

**Hottinger Brüel & Kjaer GmbH**  
 Im Tiefen See 45 · 64293 Darmstadt · Germany  
 Tel. +49 6151 803-0 · Fax +49 6151 803-9100  
 Email: [info@hbm.com](mailto:info@hbm.com) · [www.hbm.com](http://www.hbm.com)

measure and predict with confidence



# DATASHEET

## CONTROLLINO MAXI AUTOMATION

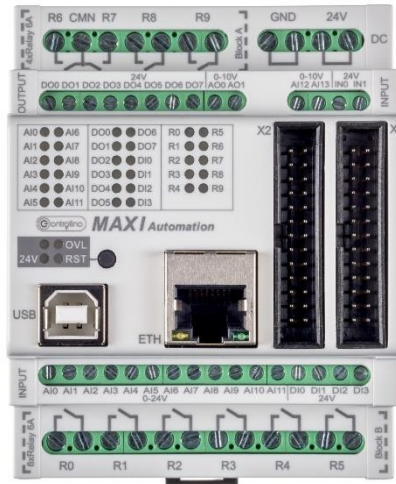

Controllino is an Arduino standard and Arduino software compatible PLC.

**Ordering information: Controllino Maxi Automation, Art.Nr: 100-101-00**

### General:

Standard	EN61010-1 EN61010-2-201 EN61131-2
Dimensions (W × H × D)	72x90x62 mm
Weight	240 g
Mounting	Top hat rail EN50022, 35 mm

### Environmental conditions, Indoor use only:

Operating ambient temperature	0 °C – 55 °C
Relative humidity – non-condensing	80 % for temp. up to 31 °C, decreasing linearly to 50 % relative humidity at 55 °C
Pollution Degree	PD2
Altitude	up to 2000 m AMSL
Vibration (5 ≤ f ≤ 9 Hz)	1,75 mm amplitude sinus 3,5 mm amplitude random
Vibration (9 ≤ f ≤ 150 Hz)	0,5 g acceleration sinus 1,0 g acceleration random
Transport and Storage	-20 °C – +70 °C 10 to 90 % no condensation Altitude 3000 m AMSL



Shock response	15 g, 11 ms half sinus all 3 axes
----------------	-----------------------------------

#### I/O:

Supply voltage	24 V
USB (Power for programming only)	USB-B, 2.0
Ethernet	RJ45, 10/100Mbps
Analog inputs	2x 0-10 V
Analog outputs	2x 0-10 V or 0-20 mA
Inputs, no galvanic insulation	18
Common analog/digital	12
Digital	4
Fixed digital, ext. Interrupt usable	2
Digital Outputs, no galvanic insulation	8
Relay outputs	10
PIN Header, no Galvanic insulation	
Logic level Input	12 parallel to terminal Inputs
Logic level Output	12 parallel to terminal Outputs
Communication	SPI, 2xUART, I2C, Reset
Internal Power	+3,3 V, +5 V, ARef, GND

#### Terminal capacities:

Relay Output, Power Input	2,5 mm <sup>2</sup> (24-12AWG)
Strip length	6-7 mm
Max. tightening torque	0,5 Nm
Digital, Analog Input Output	1,5 mm <sup>2</sup> (30-16AWG)
Strip length	5-6 mm
Max. tightening torque	0,2 Nm
Pin header connector	2x 26 Pin, Dual row, 2.54 pitch

#### Protection:

ESD HBM Class 0	Contact discharge: ±4 kV Air discharge: ±8 kV
Supply input over current protection	Internal Fuse 20 A (fast)
Relay Output	External Fuse required
Digital Output	Overload, short circuit, ESD
Signal Input	Overvoltage, ESD
Pin header connector	ESD
Current +5 V, +3,3 V	total 200 mA, resettable fuse

**Electrical characteristics:**

	Condition	Value
Supply voltage (Absolute Maximum)	24 V range	20,4 V – 30,0 V
Signal input low level	24 V range	0 V – 7,2 V
Signal input high level	24 V range	18 V – 26,4 V
Analog signal input	24 V range	0 V – 26,4 V
Signal input current	max. current	< 3 mA
Logic “0” level	@ pin header	0 V – 1,5 V
Logic “1” level	@ pin header	3 V – 5,5 V
Signal output low level	24 V range	0V – 4,8 V
Signal output high level		V <sub>in</sub> – 10 %
Signal output – PWM functionality	Duty cycle	15 % - 85 %
Relay output, Contact rating	Resistive Load	6 A 250 V AC / 30 V DC
Common Relay terminal	max. current	6 A
Galvanic insulation	coil to contact	3000 VAC 1 min
Relay ON in case of PWM functionality	Duty cycle	> 30 %

**LED signalization:**

Power LEDs coding input voltage out of range e.g. only USB powered	Color of power LED  24 V orange
input voltage 20.4 V – 30,0 V Input voltage < 5 V	24 V green LED off
Device in reset state	Reset LED yellow
Device in run state	Reset LED off
Signal input at high (logic 1) level	Corresponding LED green
Signal input at low (logic 0) level	Corresponding LED off
Signal input in use as analog input	Corresponding LED green on when input level reach high (logic 1) state
Signal/Relay output set to active	Corresponding LED green
Signal/Relay output set to inactive	Corresponding LED off

**Physical Dimensions:**

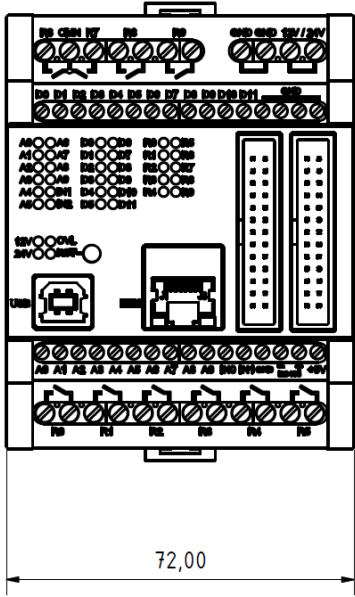
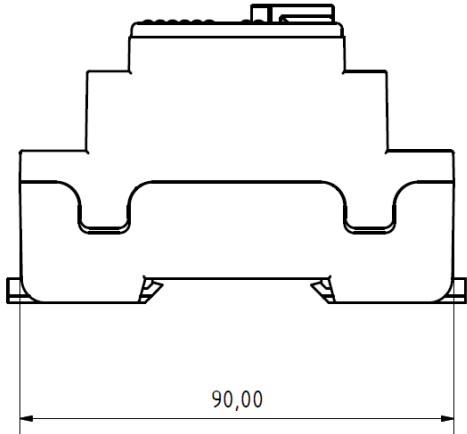
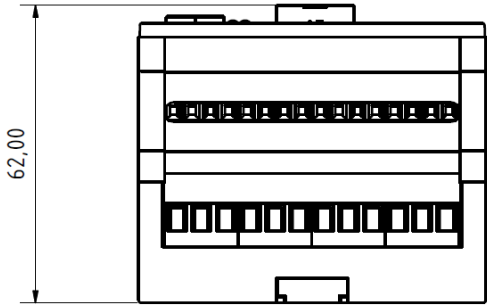



**4D SYSTEMS**  
TURNING TECHNOLOGY INTO ART

9.0" DIABLO16  
INTELLIGENT DISPLAY MODULE

# DATASHEET

DOCUMENT DATE: 11<sup>th</sup> NOVEMBER 2019  
DOCUMENT REVISION: 1.1

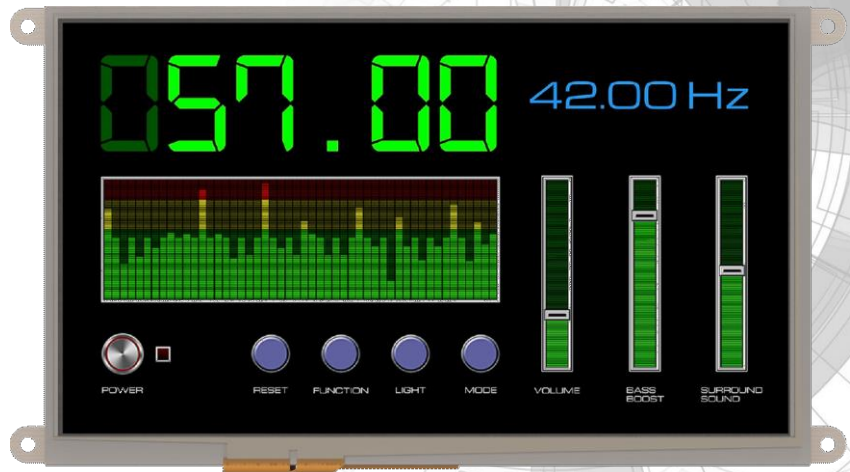

**uLCD-90DT** (Resistive Touch)  
**uLCD-90DCT** (Capacitive Touch)

Uncontrolled Copy when printed or downloaded.  
Please refer to the 4D Systems website for the latest  
Revision of this document

### 3. Hardware Overview

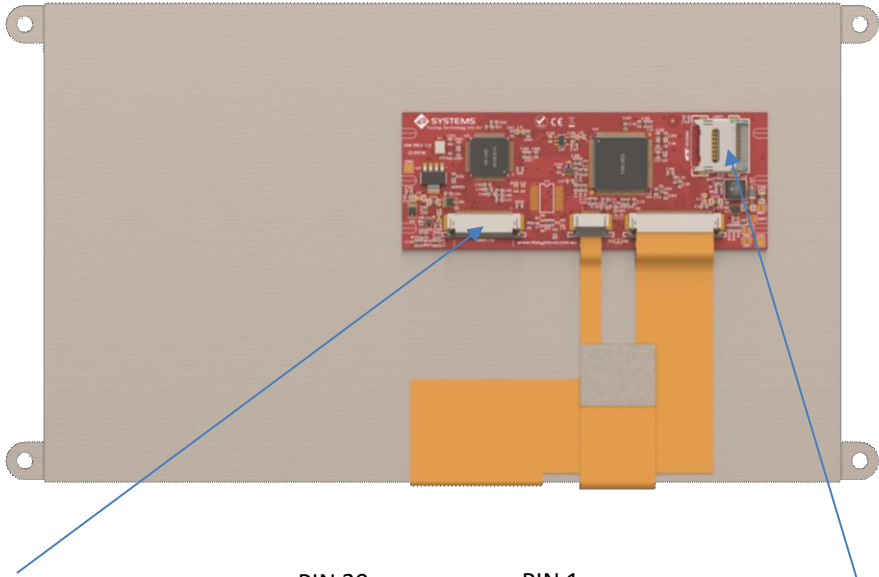

USER I/O – 30 way ZIF Socket  
 0.5mm pitch Upper Contact  
 15.5mm wide FPC Cable

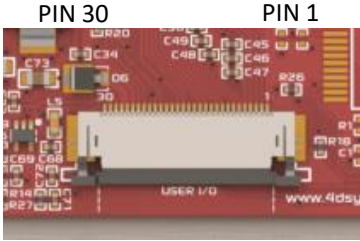

Latch Type microSD Socket

USER I/O – 30 Way FPC			
Pin	Symbol	I/O	Description
1	GND	P	Supply Ground
2	PA3	I/O/A	General Purpose I/O pin with Analog Capability. This pin has a range of 0-3.3V when used as an Analog Input, and is 3.3V tolerant only. Also used for Bus Read
3	PA2	I/O/A	General Purpose I/O pin with Analog Capability. This pin has a range of 0-3.3V when used as an Analog Input, and is 3.3V tolerant only. Also used for Bus Write
4	PA1	I/O/A	General Purpose I/O pin with Analog Capability. This pin has a range of 0-3.3V when used as an Analog Input, and is 3.3V tolerant only.
5	PA0	I/O/A	General Purpose I/O pin with Analog Capability. This pin has a range of 0-3.3V when used as an Analog Input, and is 3.3V tolerant only.
6	PA9	I/O	General Purpose Input/Output, 3.3V Level - 5V Tolerant
7	PA8	I/O	General Purpose Input/Output, 3.3V Level - 5V Tolerant
8	PA7	I/O	General Purpose Input/Output, 3.3V Level - 5V Tolerant
9	PA6	I/O	General Purpose Input/Output, 3.3V Level - 5V Tolerant
10	PA5	I/O	General Purpose Input/Output, 3.3V Level - 5V Tolerant
11	PA4	I/O	General Purpose Input/Output, 3.3V Level - 5V Tolerant
12	PA10	I/O	General Purpose Input/Output, 3.3V Level - 5V Tolerant
13	PA11	I/O	General Purpose Input/Output, 3.3V Level - 5V Tolerant
14	PA12	I/O	General Purpose Input/Output, 3.3V Level - 5V Tolerant
15	PA13	I/O	General Purpose Input/Output, 3.3V Level - 5V Tolerant
16	PA14	I/O	General Purpose Input/Output, 3.3V Tolerant only. Special I2C Pin.
17	PA15	I/O	General Purpose Input/Output, 3.3V Tolerant only. Special I2C Pin.
18	NC	-	Not Connected

Continued overleaf...

USER I/O – 30 Way FPC (continued)			
Pin	Symbol	I/O	Description
19	AUDIO_OUT	O	Audio Output, Filtered PWM, to feed into external amplifier
20	AUDENB	O	Audio Amplifier Enable, to enable/disable external amplifier
21	GND	P	Supply Ground
22	RESET	I	Master Reset signal. Internally pulled up to 3.3V via a 10K resistor. An active Low pulse greater than 2 micro-seconds will reset the module. If the module needs to be reset externally, only use open collector type circuits. This pin is not driven low by any internal conditions. The host should control this pin via one of its port pins using an open collector/drain arrangement.
23	RX0	I	Asynchronous Serial Receive pin, TTL level. Connect this pin to the Transmit (Tx) signal of other serial devices. Used in conjunction with the TX pin for programming this microLCD. This pin is tolerant up to 5.0V levels.
24	TX0	O	Asynchronous Serial Transmit pin, TTL level. Connect this pin to the Receive (Rx) signal of other serial devices. Used in conjunction with the RX pin for programming this microLCD. This pin is tolerant up to 5.0V levels.
25	GND	P	Supply Ground
26	5V IN	P	Main Voltage Supply +ve input pin. Reverse polarity protected. Range is 4.0V to 5.5V, nominal 5.0V.
27	5V IN	P	Main Voltage Supply +ve input pin. Reverse polarity protected. Range is 4.0V to 5.5V, nominal 5.0V.
28	NC	-	Not Connected
29	NC	-	Not Connected
30	GND	P	Supply Ground

I = Input, O = Output, P = Power



## 5. Module Features

The uLCD-90DT/CT displays are designed to accommodate most applications where a large physical size display module is required. Some of the main features of the module are listed below.

### 5.1. DIABLO16 Processor

The module is designed around the DIABLO16 Graphics Controller from 4D-Labs.



The DIABLO16 is a smart Controller and the interface to the TFT- LCD displays is almost plug-n-play.

All of the data and control signals are provided by the chip to interface directly to the display.

Powerful graphics, text, image, animation and countless more features are built right inside the chip.

The data sheet for the processor is available from the <http://www.4dsystems.com.au> website: **"DIABLO16 Processor Datasheet"**

### 5.2. Audio

Audio playback support in the DIABLO16 Processor enables this module to play audio WAV files stored in the micro-SD memory card. Filtered PWM audio is generated and made available on the AUDIO pin of the 30 way ZIF connector, ready to interface with an audio amplifier on your application board.

A simple instruction enables the user to play/pause/stop audio files while continuing the execution of the user application code, such as display updates, touch recognition, communications, etc. The audio system also allows real time pitch change of audio samples.

For a complete list of audio commands please refer to the separate document titled: **"DIABLO16 4DGL Internal Functions"**

### 5.3. SD/SDHC Memory Cards

The module supports micro-SD memory cards via the on-board latch type micro-SD connector. The memory card is used for all multimedia file retrieval such as images, animations and movie clips. The memory card can also be used as general purpose storage for data logging applications. Support is available for off-the-shelf micro-SD (< 4GB) and high capacity HC memory cards (4GB and above). Memory cards up to 32GB is size can be used, however it must be noted that only a portion of this can be utilised by the FAT16 file system. See section below for more details.



**Note:** A microSD card capable of SPI is a requirement for all 4D Systems' display modules powered by Goldelox, Picaso or Diablo16 Processors. If a non-SPI compatible card is used, it will simply fail to mount, or may cause intermittent issues resulting in lock ups and crashing of the application. Please refer to the 4D Systems website for microSD cards offered by 4D Systems.

### 5.4. FAT16

All 4D Systems display modules featuring 4D Labs processors use off-the-shelf standard SDHC/SD/micro-SD memory cards (SPI Compatible Only) with up to 4GB capacity usable with FAT16 formatting.

For any FAT file related operations, before the memory card can be used it must first be formatted correctly. Built into Workshop4 is a tool created by 4D, called RMPET (please refer to the Tools menu, in any Environment, inside the Workshop4 IDE). RMPET allows the User to easily partition and format microSD cards, to make their file system ready to be used with 4D Systems modules. The formatting of the card can be done on any PC system with a card reader.

The DIABLO16 Processor also supports high capacity HC memory cards (4GB and above). The available capacity of SD-HC cards varies according to the way the card is partitioned and the commands used to access it. Refer to the 4D Systems RMPET tool in the Workshop4 IDE.

A Max of 4GB can be utilised by the FAT16 file system. The FAT partition is always first (if it exists). Any space larger than 4GB will be RAW, and can still be utilised by your 4D Systems module, using different functions. Please refer to Application Notes.





## 15. Specifications

### ABSOLUTE MAXIMUM RATINGS

Operating ambient temperature .....	-20°C to +70°C
Storage temperature .....	-30°C to +80°C
Voltage on any digital input pin with respect to GND .....	-0.3V to 6.0V
Voltage on VCC with respect to GND .....	-0.3V to 6.0V
Maximum current sunk/sourced by any pin .....	10.0mA
Maximum current sunk/sourced by all ports .....	200.0mA

**NOTE:** Stresses above those listed here may cause permanent damage to the device. This is a stress rating only and functional operation of the device at those or any other conditions above those indicated in the recommended operation listings of this specification is not implied. Exposure to maximum rating conditions for extended periods may affect device reliability.

### RECOMMENDED OPERATING CONDITIONS

Parameter	Conditions	Min	Typ	Max	Units
Supply Voltage (VCC)	Stable external supply required	4.0	5.0	5.5	V
Processor voltage (VP)		--	3.3	--	V
Operating Temperature		-10	--	+60	°C
Input Low Voltage (VIL)	all pins	0	--	0.2VP	V
Input High Voltage (VIH)	non 5V tolerant pins	0.8VP	--	3.3	V
Input High Voltage (VIH)	PA4-PA13, RX0 and TX0 pins	0.8VP	--	5.5	V
Reset Pulse	External Open Collector	2.0	--	--	µs
Operational Delay	Power-Up or External Reset	500	--	3000	ms

### GLOBAL CHARACTERISTICS BASED ON OPERATING CONDITIONS

Parameter	Conditions	Min	Typ	Max	Units
Supply Current (ICC) (5V Supply used)	uLCD-90D (Contrast = 15)	9	760	--	mA
	uLCD-90DT (Contrast = 15)	9	766	--	mA
	uLCD-90DCT (Contrast = 15)	9	784	--	mA
Display Endurance	Hours of operation, measured to when display is 50% original brightness	30000	--	--	H
Touch Screen Endurance (Resistive Touch)	Number of touches/hits with a 12.5mm tip at a rate of 2x per second with 250gf force	--	1M	--	Touches
	Slide stylus on screen, 100gf force, 60mm/s speed with a 0.8mm polyacetal tip stylus pen	--	100K	--	Slides
Touch Screen Transparency	Resistive Touch	82	--	--	%
	Capacitive Touch	90	--	--	%
Touch Screen Operational Force (Resistive Touch)	Only use Finger or Stylus, do not use anything sharp or metal	20	--	100	Gf
CTP Hardness	Glass Hardness	--	6	--	H

LCD DISPLAY INFORMATION		
Parameter	Conditions	Specification
Display Type		TFT Transmissive LCD
Display Size		9.0" Diagonal
Display Resolution		800 x 480 (Landscape/Wide Viewing)
Display Brightness	uLCD-90D (Contrast = 15) - Typical	500 cd/m <sup>2</sup>
	uLCD-90DT (Contrast = 15) - Typical	450 cd/m <sup>2</sup>
	uLCD-90DCT (Contrast = 15) - Typical	475 cd/m <sup>2</sup>
Display Contrast Ratio	Typical	500:1
Display Viewing Angles	Above Centre	70 Degrees
	Below Centre	60 Degrees
	Left of Centre	70 Degrees
	Right of Centre	70 Degrees
Display Viewing Direction		12 o'clock Display (Optimal viewing is from above when in Landscape/Wide mode)
Display Backlighting	White LED's	11x3 Parallel LED's
Pixel Pitch	Width x Height – Landscape mode	0.2475 x 0.2327mm (non-Square pixels)
Pixel Density	Number of pixels in 1 row in 25.4mm	103 DPI/PPI (Horizontal) 109 DPI/PPI (Vertical)