

Tehno-ekonomska analiza razvoja novog tipa brodskog motora niske razine buke i vibracija

Tudor, Hana

Master's thesis / Diplomski rad

2017

Degree Grantor / Ustanova koja je dodijelila akademski / stručni stupanj: **University of Zagreb, Faculty of Mechanical Engineering and Naval Architecture / Sveučilište u Zagrebu, Fakultet strojarstva i brodogradnje**

Permanent link / Trajna poveznica: <https://urn.nsk.hr/urn:nbn:hr:235:495581>

Rights / Prava: [In copyright](#)/[Zaštićeno autorskim pravom.](#)

Download date / Datum preuzimanja: **2024-07-17**

Repository / Repozitorij:

[Repository of Faculty of Mechanical Engineering and Naval Architecture University of Zagreb](#)



UNIVERSITY OF ZAGREB
Faculty of Mechanical Engineering and Naval Architecture

MASTER'S THESIS

Hana Tudor

Zagreb, 2017.

UNIVERSITY OF ZAGREB
Faculty of Mechanical Engineering and Naval Architecture

MASTER'S THESIS

Supervisor:

Doc. dr. sc. Nikola Vladimir, dipl. ing.

Student:

Hana Tudor

Zagreb, 2017.

I hereby declare that this thesis is entirely the result of my own work except where otherwise indicated. I have fully cited all used sources and I have only used the ones given in the list of references.

I would first like to acknowledge my thesis advisor Assistant Professor Nikola Vladimir at the Faculty of Mechanical Engineering and Naval Architecture of the University of Zagreb for allowing me to choose this topic for my thesis and guiding me throughout the entire process. Furthermore, I would like to express my gratitude to my supervisor Carlo Pestelli at Wartsila in Trieste, Italy for his invaluable guidance and continuous encouragement. Likewise, I would like to thank the rest of the Noise and Vibration team: Francesco Degano, Moreno Almerigogna and Marco Pandolfi, for their support, consideration, help, and entertainment whenever I needed it.

Finally, I have to extend my heartfelt gratitude to my family and friends for providing me with support, and for enduring my yammering throughout my years of college. Without their unfailing encouragement, this accomplishment would not have been possible.

Hana Tudor



SVEUČILIŠTE U ZAGREBU
FAKULTET STROJARSTVA I BRODOGRADNJE



Središnje povjerenstvo za završne i diplomske ispite
Povjerenstvo za diplomske ispite studija strojarstva za smjerove:
procesno-energetski, konstrukcijski, brodstrojarski i inženjersko modeliranje i računalne simulacije

Sveučilište u Zagrebu Fakultet strojarstva i brodogradnje	
Datum	Prilog
Klasa:	
Ur. broj:	

DIPLOMSKI ZADATAK

Student: **Hana Tudor**

Mat. br.: 0069053336

Naslov rada na hrvatskom jeziku: **Tehno-ekonomska analiza razvoja novog tipa brodskog motora niske razine buke i vibracija**

Naslov rada na engleskom jeziku: **Techno-economic assessment of new marine engine development with high noise and vibration performance**

Opis zadatka:

Buka i vibracije na brodovima, koje nastaju uslijed rada brodskih strojeva i uređaja, redovite su i neželjene pojave koje je potrebno držati u dopuštenim granicama. Jedan od glavnih izvora buke i vibracija je glavni stroj. U diplomskom radu potrebno je provesti tehno-ekonomsku analizu razvoja brodskog četverotaktnog dizelskog motora niske razine buke i vibracija, prvenstveno namijenjenog za instalaciju na putničkim brodovima. Zadatak treba obuhvatiti osnovni opis problematike vibracija i buke na brodovima, detaljnu analizu regulative s naglaskom na pravila vodećih klasifikacijskih društava, te opis tzv. *Comfort Class* kojim bi se unaprijedila razina sigurnosti i komfora na brodovima. Obraditi osnovne modalitete propagacije buke i vibracija, te principe redukcije navedenih fenomena. Tehno-ekonomsku analizu potrebno je provesti na primjeru flote velikih putničkih brodova za kružna putovanja, uključujući definiciju, prikupljanje i obradu relevantnih podataka o buci i vibracijama i njihovom utjecaju na cijene putničkih kabina. Na temelju analize dati preliminarne zaključke o isplativosti razvoja novog tipa brodskog motora u usporedbi s cijenama tehničkih rješenja za redukciju buke i vibracija već razvijenih motora. Na jednostavnom primjeru brodskih nastambi ilustrirati utjecaj značaja izvora buke i zvučne izolacije na razine buke, služeći se komercijalnim programskim paketom Designer-NOISE.

U radu je potrebno navesti korištenu literaturu i eventualno dobivenu pomoć.

Zadatak zadan:

11. svibnja 2017.

Rok predaje rada:

13. srpnja 2017.

Predvideni datum obrane:

19., 20. i 21. srpnja 2017.

Zadatak zadao:

Doc. dr. sc. Nikola Vladimirović

Predsjednica Povjerenstva:

Prof. dr. sc. Tanja Jurčević Lulić

TABLE OF CONTENTS

1. INTRODUCTION	1
2. THEORETICAL BACKGROUND	3
2.1. Basic concepts of noise problems on board	3
2.2. Noise measurement	5
2.3. Basic concepts of vibration problems in ships	7
2.4. Vibration measurement	8
2.5. Source – Path – Receiver concept	9
2.6. Four stroke engine as an excitation source	10
2.7. Propeller as an excitation source	13
3. REQUIREMENTS OF CLASSIFICATION SOCIETIES	16
3.1. DNV-GL Comfort Class	18
3.2. Lloyd's Register: Passenger and Crew Accommodation Comfort	19
3.3. Bureau Veritas Comfort on board class	19
4. CORRELATION ANALYSIS OF MEASURED ENGINE RESPONSE AND PRESCRIBED LIMIT VALUES	21
4.1. Prescribed limit values of ship structure vibration response	21
4.2. Measured forces on the engine	28
5. TECHNO - ECONOMIC ASSESSMENT	51
5.1. The decks	51
5.2. The Aft	54
5.3. The Middle	55
5.4. The Bow	56
5.5. Cabin prices	57
6. ANALYSIS OF NOISE INFLUENCING PARAMETERS	66
6.1. Outline of the used software	66
6.2. Model description	67
6.3. Results	68
7. CONCLUSION	75
7.1. Concluding remarks of the thesis	75
7.2. Recommendations for further research	76
REFERENCES	78
APPENDIX	80

LIST OF FIGURES

Figure 1 Main noise and vibration sources onboard [1].....	3
Figure 2 Engine noise and vibration source with corresponding transmission paths [1].....	5
Figure 3 Measurement positions according to Lloyd's Register of Shipping [8].....	9
Figure 4 Source-Path-Receiver model	9
Figure 5 Excitation forces generated by the engine interacting with ship structure external emitters [1]	13
Figure 6 Propeller blade forces [9].....	14
Figure 7 Vibration assessment levels for accommodation and workplace [8].....	26
Figure 8 Assessment levels for reciprocating machinery [8]	27
Figure 9 Force F_z distribution for Engine type 1	32
Figure 10 Force F_z distribution for Engine type 2	32
Figure 11 Force F_z distribution for Engine type 3	33
Figure 12 Force F_z distribution for Engine type 4	33
Figure 13 Force F_z distribution for Engine type 5	34
Figure 14 Force F_z distribution for all engine types	34
Figure 15 Main excitations of a reciprocating engine [1]	35
Figure 16 From source to receiver on board ship scheme [1].....	36
Figure 17 Wärtsilä's diesel engine without and with engine cover	37
Figure 18 Typical engine mounting schemes [1]	37
Figure 19 Vibratory response at standard passenger cabin depending on ship transfer functions	44
Figure 20 Progress in class from crn=3 to crn=2 due to engine improvement	45
Figure 21 Progress in class from crn=3 to crn=1 due to engine improvement	45
Figure 22 Sustaining the same crn=2 with lower ship quality and engine improvement	46
Figure 23 Sustaining the same crn=1 with lower ship quality and engine improvement	47
Figure 24 Vibratory response at standard passenger cabin for averaged ship transfer functions, DNV-GL.....	49
Figure 25 Vibratory response at standard passenger cabin for averaged ship transfer functions, LR.....	50

Figure 26 Vibratory response at standard passenger cabin for averaged ship transfer functions, BV	50
Figure 27 5 TH deck Petrarca on MSC Poesia [16].....	62
Figure 28 6 TH deck Dante on MSC Poesia [16]	62
Figure 29 7 TH deck Manzoni on MSC Poesia [16].....	62
Figure 30 8 TH deck Tasso on MSC Poesia [16]	63
Figure 31 9 TH deck Ungaretti on MSC Poesia [16].....	63
Figure 32 10 TH deck Carducci on MSC Poesia [16]	63
Figure 33 11 TH deck D'Annunzio on MSC Poesia [16]	64
Figure 34 12 TH deck Leopardi on MSC Poesia [16]	64
Figure 35 13 TH deck Foscolo on MSC Poesia [16]	64
Figure 36 14 TH deck Pascoli on MSC Poesia [16]	65
Figure 37 15 TH deck Alfieri on MSC Poesia [16]	65
Figure 38 16 TH deck Sport on MSC Poesia [16]	65
Figure 39 Simple model for noise analysis	67
Figure 40 Noise analysis results for steel thickness of 10 mm	69
Figure 41 Noise calculated in the point of interest.....	70
Figure 42 Case of the closest engine to the compartment.....	73
Figure 43 Case of the most distant engine to the compartment	73

LIST OF TABLES

Table 1 Maximum allowable values of vibration (mm/s) according to different Classification Societies.....	23
Table 2 Measured forces on the Engine type 1	29
Table 3 Measured forces on the Engine type 2	30
Table 4 Measured forces on the Engine type 3	30
Table 5 Measured forces on the Engine type 4	31
Table 6 Measured forces on the Engine type 5	31
Table 7 Maximum values of engine's excitation forces F_z	40
Table 8 DNV-GL standard passenger cabin requirements.....	40
Table 9 Input data for calculating transfer functions	40
Table 10 Transfer functions	41
Table 11 Engine type 1, response at standard passenger cabin.....	41
Table 12 Engine type 2, response at standard passenger cabin.....	42
Table 13 Engine type 3, response at standard passenger cabin.....	42
Table 14 Engine type 4, response at standard passenger cabin.....	43
Table 15 Engine type 5, response at standard passenger cabin.....	43
Table 16 Vibration response at the standard passenger cabin location for DNV-GL.....	47
Table 17 Vibration response at the standard passenger cabin location for LR	48
Table 18 Vibration response at the standard passenger cabin location for BV>1600 GT	48
Table 19 General characteristics of MSC Musica fleet.....	51
Table 20 Cabin prices on MSC Poesia [16]	57
Table 21 Noise levels in dB(A) analyzed for overall frequencies	71
Table 22 Properties of different insulation materials	71
Table 23 Noise levels in dB(A) for insulation materials and thickness	72
Table 24 Noise levels in the observed compartment according to the engine position	73

NOMENCLATURE

c	m/s	Sound velocity
e	-	Maximum measured force on the engine
f	Hz	Frequency
F	-	Measured force on the engine
l	mm/s	Vibration velocity
p	Pa	Sound pressure
P	N	Force on a propeller blade
q_E	-	Quality of the engine
S	-	Transfer function
T	s	Time

ABBREVIATIONS

ABN – Air-borne Noise

BV – Bureau Veritas

crn – Comfort Rating Number

DNV–GL – Det Norske Veritas – Germanischer Lloyd

EGN – Exhaust Gas Noise

FAT – Factory Acceptance Test

LR – Lloyd's Register of Shipping

MCR - Maximum Continuous Rating

RMS – Root Mean Square

SAT – Site Acceptance Test

SBN – Structure-borne Noise

SEA – Statistical Energy Analysis

SAŽETAK

Općenito je poznato da problemi buke i vibracija karakteriziraju gotovo sve brodove. To je posebice naglašeno kod malih brodova, putničkih brodova i velikih kruzera. Ovaj diplomski rad vezan je za problem buke i vibracija na kruzera, koji su prvenstveno uzrokovani radom četverotaktnih dizelskih motora. Naime, većina od prezentiranih rezultata u okviru ovog rada plod je istraživanja autorice za vrijeme tromjesečnog boravka u razvojnom odjelu proizvođača brodskih motora Wärtsilä u Trstu. Štoviše, istraživanja koja su provedena u okviru ovog rada predstavljaju početni dio dugogodišnjeg istraživačkog projekta koji provodi Wärtsilä s ciljem razvoja motora niske razine buke i vibracija. U tom smislu kao glavno pitanje postavlja se dvojba trebaju li se propisane razine buke i vibracija nastojati ostvariti konverzijama postojećih motora ili razvojem potpuno novih motora. Također, potrebno je dati odgovor na pitanje jesu li samo zahvati na motoru dovoljni ili su nužni i zahvati na samoj konstrukciji broda. Stoga, u radu je dan pregled problema buke i vibracija na brodovima. Opisani su osnovni principi njihove propagacije kroz konstrukciju. Analizirani su zahtjevi klasifikacijskih društava prema tzv. klasama komfora, kao i izmereni rezultati u naravi na postojećim brodovima. Uspostavljen je odnos između poboljšanja kvalitete motora i klase komfora. Utjecaj vibracija na cijene putničkih kabina analiziran je na temelju stvarnih podataka za brodove za kružna putovanja. Naposljetku, generiran je pojednostavljeni model buke na brodovima, koji je razmatran hibridnom statističkom analizom energije kako bi se identificirali dominantni utjecajni parametri buke koje valja varirati kako bi se smanjile njene razine na brodu. Zajedno sa zaključnim razmatranjima diplomskog rada, dane su smjernice za buduća istraživanja.

Ključne riječi: buka i vibracije, glavni stroj, klasifikacijsko društvo, klasa komfora, Designer-NOISE, izvor – put – prijemnik model

PROŠIRENI SAŽETAK

Kada se govori o buci i vibracijama obično se podrazumijevaju negativni utjecaji buke i vibracija na ljude, strojeve i brodske konstrukcije. Buka i vibracije oduvijek su bili jedan od većih problema koji su opterećivali brodovlasnike i brodograditelje, uglavnom zbog brige za njihove štetne utjecaje na ljudski organizam, te pouzdanosti strojeva i uređaja koji se nalaze na brodovima. Zbog općeg povećanja brzine brodova, pojavila se potreba za snažnijim i efikasnijim prvopokretačima (uglavnom motorima s unutarnjim izgaranjem), što znači i povećanje njihovih performansi, ali neminovno i veće razine uzbude. Prva pravila za kontroliranje i reguliranje buke i vibracija plod su rada međunarodnih regulatornih agencija i klasifikacijskih društava. Prvenstveno su to bila pravila kojima su propisane takve razine buke i vibracija da se očuva pouzdanost uređaja i strojeva, te zdravlje i sigurnost posade, radnika i putnika na brodu. S povećanjem interesa za putničke brodove i tzv. brodove za kružna putovanja, razvijaju se nova pravila pod nazivom „*Comfort Class*“ tj. klase udobnosti (komfora), koja propisuju još niže granice buke i vibracija kako bi se putnicima i posadi osigurao što udobniji boravak na brodovima za kružna putovanja, ali i ostalim trgovačkim brodovima. Vodeća klasifikacijska društva u Zahtjevima za udobnošću su DNV-GL, koji je prvi izdao regulative ovakve vrste, te Lloyd's Register of Shipping i Bureau Veritas, koji slijede DNV-GL s vrlo sličnim regulativama koja objedinjuju pravila za udobnost putnika i posade. Cilj tih pravila je postizanje kontroliranog okruženja za sve ljude koji obitavaju na brodu i na taj način su izloženi buci i vibracijama koje su redovito neželjena i neugodna pojava, ali mogu biti i opasna po zdravlje.

Glavne izvore buke na brodu predstavljaju: glavni i pomoćni strojevi, reduktori, sustavi ventilacije i klimatizacije, ispušni sustav, pumpe i kompresori, brodski propulzori, itd., Slika 1. Glavni izvori vibracija na brodu redovito su glavni stroj i brodski vijak.

Budući da je otklanjanje vibroakustičkih problema broda u završnoj fazi njegove izgradnje razmjerno skup postupak, poželjno je što prije takve probleme predvidjeti i poduzeti odgovarajuće mjere za njihovo otklanjanje. U tom smislu koriste se metode različite razine složenosti i točnosti. Za probleme vibracija danas je najraširenija metoda konačnih elemenata, dok se za analizu buke na brodovima najčešće koristi statistička analiza energije.

Radi boljeg razumijevanja buke i vibracija, te osnovnih modaliteta njihove propagacije koristi se linearni model koji opisuje izvor buke i vibracija, transmisijski put kojim se buka i vibracije šire, te njihov odziv na poziciji prijemnika, u ovom slučaju putnika i posade, Slika 2

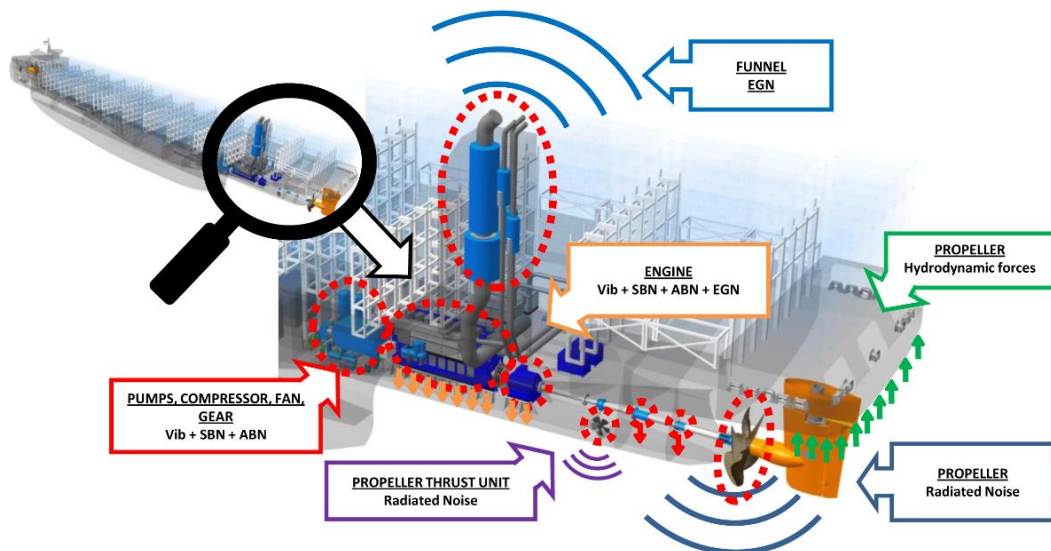

Slika 1 Glavni izvori buke na brodu

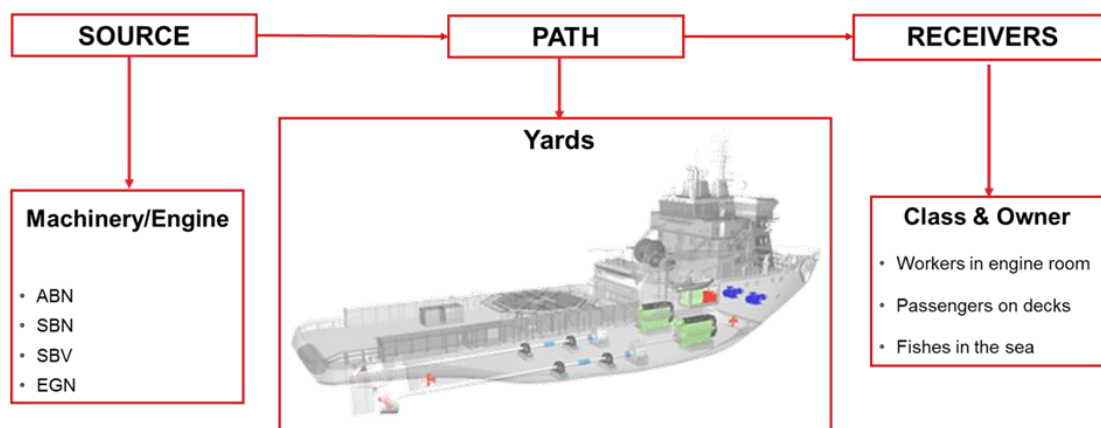

Slika 2 Koncept propagacije energije izvora do prijemnika

Buka i vibracije se mogu umanjiti tako da se smanji pobuda na izvoru, što bi značilo smanjenje uzbudnih sila izgaranja motora. Sljedeći način umanjivanja odziva na mjestu prijemnika je poboljšavanje transmisijskog puta na način da mu se smanji sposobnost provođenja vibracija što se može postići povećanjem njegove krutosti ili korištenjem plivajućeg poda. Osim toga, buka i vibracije mogu se smanjiti na mjestu prijemnika tako da se osoba opremi odgovarajućom odjećom, obućom i slušalicama.

Ovaj diplomski rad usko je vezan za nedavno započeta istraživanja proizvođača brodskih motora Wärtsilä, kojima se želi dati odgovor u kojem smjeru je potrebno razvijati brodske četverotaktne dizelske motore imajući u vidu postojeće, ali i predvidive zakonske okvire u kojima se dopuštene razine buke i vibracija na brodovima smiju kretati. Naime, izmjerene razine buke i vibracija na brodovima posljedica su uzajamne interakcije broskog stroja i broskog trupa i nisu jednoznačno definirane samo jednim od ovih subjekata. To znači da se bez obzira na razinu kvalitete motora ili broda, ako samo jedan od njih ima neprikladne vibroakustičke značajke, mogu javiti prekomjerne razine buke i vibracija. Neovisno o tome, brodogradilišta i brodovlasnici pokušavaju teret smanjenja razina spomenutih fenomena prebaciti na proizvođače brodskih strojeva i opreme, što znatno poskupljuje njihov proizvodni proces. Kako bi doskočio ovom problemu, proizvođač brodskih motora Wärtsilä pokrenuo je višegodišnji istraživački projekt, kojem je u prvom koraku cilj odgovoriti na pitanje je li ekonomski isplativije i tehnički prikladnije razvijati potpuno nove tipove motora niske razine buke i vibracija ili je pogodnije rješenja potražiti uz postojeće motore ali i određene zahvate na samoj konstrukciji broda. Minimalni zahvati na postojećim motorima, uz minimalne zahvate na brodskoj konstrukciji, također su opcija koju je potrebno razmotriti. Ovaj diplomski rad nastao je kroz suradnju diplomantice s tvornicom brodskih motora Wärtsilä i aktivnim radom na spomenutom projektu, tijekom tromjesečnog boravka u njihovom razvojnom odjelu u Trstu, Italija. U samom radu obrađena je problematika buke i vibracija na putničkim brodovima sa četverotaktnim motorom kao izvorom uzbude. Najprije je analizirana regulativa gore spomenutih klasifikacijskih društava, s naglaskom na *Comfort Class*. Analiza kvalitativnih podataka klasifikacijskih društava poslužila je kao smjernica za razumijevanje razina odziva buke i vibracija sa stajališta prijemnika. Podaci mjerene sile na motoru prikupljeni su od proizvođača motora te oni predstavljaju informacije kojima se opisuje uzbuda. Uz pomoć podataka odziva na brodu i uzbude na motoru analizirane su propagacijske značajke broda. Zbog opsega projekta i njegovog planiranog višegodišnjeg trajanja, ovaj diplomski rad uključuje reducirani skup aktivnosti koji je vezan za:

- razumijevanje osnovnih modaliteta širenja buke i vibracija na brodu,
- pregled zahtjeva klasifikacijskih društava,
- prikupljanje i analizu podataka o vibracijama motora i broskog trupa (nadgrađa) brodova iz flote za kružna putovanja,
- utjecaj navedenih podataka o razinama buke i vibracija na cijene putničkih kabina na spomenutim brodovima (tehno-ekonomsku analizu),

-
- preliminarne zaključke o smjeru u kojem se trebaju kretati daljnja istraživanja.

U skladu s planiranom dinamikom projekta, poseban naglasak u ovom diplomskom radu je na vibracijskim značajkama, dok su za akustičke značajke izvedeni samo osnovni zaključci na temelju analize utjecajnih parametara na širenje zvuka, kroz proračune na pojednostavljenim modelima brodskih nastambi, korištenjem komercijalnog programskog paketa Designer-NOISE. Neovisno o tome, razvijeni način prikupljanja podataka i njihova obrada po istom se principu može primijeniti na akustičke podatke.

SUMMARY

It is well known that noise and vibration are problems that are inherent to almost all ships. This is particularly emphasized in case on small ships, passenger vessels and large cruise ships. This thesis deals with noise and vibration problems onboard cruise ships that are primarily induced by four stroke diesel engines. Namely, the most of the presented research results was performed during the 3-month visit of the author to the engine producer Wärtsilä. Moreover, the investigation performed within this thesis is an initial part of long-term research project which is being performed by Wärtsilä with an aim to develop an engine with low emissions of noise and vibration. In this sense, the main issue is whether the prescribed noise and vibration levels should be achieved by conversions of existing engines, or completely new engine should be developed. Also, it is to be found whether only treatments on the engines are enough, or there are some modifications on ship structures that should be undertaken. In this work an overview of noise and vibration problems in ships is given. Basic principles of their propagation within the structure are described, together with brief description of measurement techniques. Requirements of Classification Societies on Comfort Class are analyzed in details as well as the measured full-scale results from the existing engines/ships. The relation between improvements in engine quality and comfort class is established. The influence of vibration levels on cabin prices is analyzed taking into account realistic data of cruise ship fleet. Finally, a simplified noise model is generated and analyzed by the hybrid Statistical Energy Analysis in order to specify most dominant influence parameters onboard, that should be changed to achieve lower noise levels. Together with thesis concluding remarks, recommendations for further research are given.

Key words: noise and vibration, main engine, Classification Society, comfort class, Designer-NOISE, source-path-receiver model

1. INTRODUCTION

Noise and vibration have always been priority for the ship builders, where primarily the concern was about reliability of the components, but nowadays it is also mandatory to review noise and vibration due to comfort, health and safety. The need for faster and bigger ships demanded the increase in the engine performance, which inevitably leads to excessive noise and vibration. The common working concept of most of the machinery on board is that certain internal forces are applied to the machinery structure and then transformed into noise and vibration. Since the internal excitations are mainly driven by machine performance they can hardly be reduced [1]. Therefore, with the increase of the engine's performance, internal forces increase, too. So, it can be concluded that one of the main reasons behind the increase of noise and vibration is that machinery have to increase performance so excitation forces are increasing. The other thing that increases vibration is the weakening of machinery structures in order to decrease its weight and consequently the costs. Beside engine as a noise and vibration source, ship structure significantly changed its topology in the last decades. Optimisation techniques and numerical methods ensured minimum weight with reduced amount of steel, also influencing noise and vibration propagation properties of a structure.

At the same time Classification Societies lowered the limit of the maximum allowed vibration velocity and noise. Stricter rules are needed to protect crew, workers and the passengers on board ship because noise and vibration cause various side effects, such as fatigue, stomach problems, headache, and these side effects can cause concentration drop, which consequently increases the possibility of injury. Vibration induced health conditions progress slowly, which makes them even more dangerous because they are not easy to be recognized. Long-term exposure can lead to damage of cardiovascular system, nervous system, reproductive organs and respiratory, endocrine and metabolic changes. Damage to the body from exposure to vibration mostly depends on the length of exposure time and vibration frequency and amplitude.

Also, lowering the limit of noise and vibration is desirable because it enhances the comfort and habitability of crew, workers and passengers. An example of recent regulation on safety due to Noise issue is SOLAS Regulation II-1/3-12 (Safety of Life at Sea) that recall IMO Code on Noise Levels on Board Ships - Annex 1 Resolution MSC.337(91) [2].

Until recently, Classification Societies have had classification requirements just for health and safety of the crew and workers on board, but nowadays Classification Societies together with ship owners started to raise awareness about importance of comfort on board. There are several reasons why comfort on board is important.

Health and Safety Class notations are crucial imperatives, and must not be neglected, and Comfort Class is an important extension to the health and safety requirements. Even if the noise and vibration are under the maximum health and safety limit, the negative impact on human beings is not cancelled, just reduced to the acceptable limit. The impact of acceptable level of noise and vibration on crew and workers is less direct but it still exists.

So, as the Classification Societies lowered the limit of allowed noise and vibration response, certain noise and vibration mitigation measures must be implemented in order to fulfill given requirements. One of the aims of this thesis is to investigate basic modalities of propagation on noise and vibration on board. Further, it includes review of the Classification Societies requirements regarding comfort on board ship, collection and analysis of measured engine data, analysis of relation of mentioned data on noise and vibration in passenger's cabins and finally the cabin prices. It is also investigated how much should vibration be mitigated in order to fulfill Comfort Class requirements. All above steps are performed in order to establish a direction in the development of an engine which should finally produce lower noise and vibration levels on board and therefore the relation between improvements in engine quality and Comfort Class is established. In addition, a simplified noise model is generated and analyzed by the hybrid Statistical Energy Analysis in order to specify most dominant noise influencing parameters onboard. Together with thesis concluding remarks, recommendations for further research are drawn.

2. THEORETICAL BACKGROUND

As indicated in the Introduction, noise and vibration problems are inherent to all ship structures due to a number of engines and devices needed for ship operation. The main noise and vibration sources are shown in Figure 1. Vibration is defined as the time dependent periodical movement around the equilibrium point. The sound is the vibration in the audible range that goes from 20 Hz to 20 kHz. Physically, noise is indistinguishable from sound, because both sound and noise are vibrations of the medium that surrounds us. But at the receiver's point of view, the difference between them is that receiver recognizes noise as unpleasant and annoying [3].

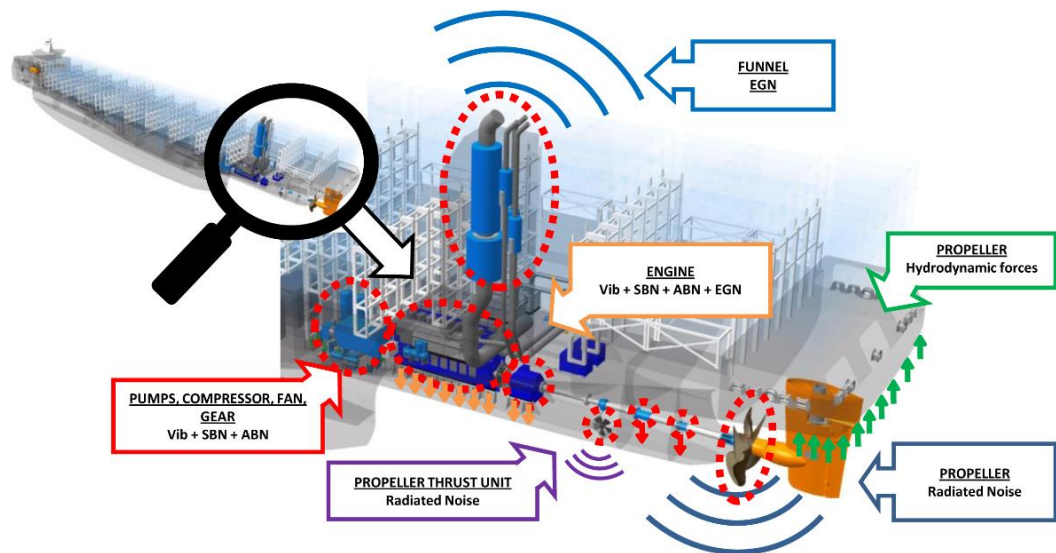

Figure 1 Main noise and vibration sources onboard [1]

2.1. Basic concepts of noise problems on board

Sound is propagated through a medium by means of wave motion. In wave propagation, the medium does not move, but only the disturbance, for example, the hump on the water surface is the case of water wave. That hump is the excess pressure p . Such an excess pressure produced at one point does not remain there but moves through fluid with velocity c , which is called the velocity of sound [3].

When a sound wave strikes a surface separating media of different density and elasticity, reflection and refraction occur. The laws governing these phenomena are the same as those for the light. The incident wave normal makes the same angle with the normal to the surface as the reflected wave normal, and both lie in the same plane [3].

Diffraction is a phenomenon when sound experiences bending around obstacles, what is intuitive for us because for instance sound can be heard around the corner. The bending of sound waves due to diffraction becomes less marked as the wavelength decreases relative to the spatial dimensions of the diffracting obstacles [3].

Attenuation is a physical phenomenon when sound passes through physical medium, its intensity decreases with distance from the source. Part of this is due to the geometrical spreading of the wave front, unless it is confined in a tube or duct. The rest of the attenuation is due to the influence of the medium and the surfaces through which the sound passes. Reflection, refraction, and scattering can all serve to increase the effective attenuation of sound propagation. The medium itself produces attenuation by changing a part of acoustic energy into heat, a kind of attenuation known as absorption [3].

The noise consists of two parts which are fundamentally transmitted through two different transmission paths. Depending on how far from the noise and vibration source we are, the structure-borne noise (SBN) on board is usually the biggest problem. Air-borne noise (ABN) must be insulated whereas structure-borne noise must be reduced by isolating it from the rest of the vessel structure. Lowering exhaust gas noise (EGN) is generally difficult because funnel goes through the ship and around the funnel there are accommodation spaces for crew and passengers.

Depending on the part of the ship, the stern, the middle or the aft, different type of noise affects each part of the ship. Air-borne noise, as it travels through the air, is very quickly dissipated, and cannot make much influence far from the engine, therefore structure-borne noise has the greatest influence on the bow. Regarding the middle part of a ship, the greatest impact has exhaust gas noise, because of the nearness of the funnel, and secondly structure-borne noise. Lastly, the stern has the most noise and vibration problems because of the nearness of the engine and the propeller. Here are primarily dominant structure-borne noise, air-borne noise, and because of the nearness of the engine exhaust gas noise should not be neglected.

Figure 2 shows a four stroke engine in an engine, where main noise paths are highlighted: vibration at engine mounting feet that is transformed in the first structure-borne noise path

and air-borne noise that radiates in the room and generates second structure-borne noise path.

Both paths will generate air-borne noise at the receiver's location [13].

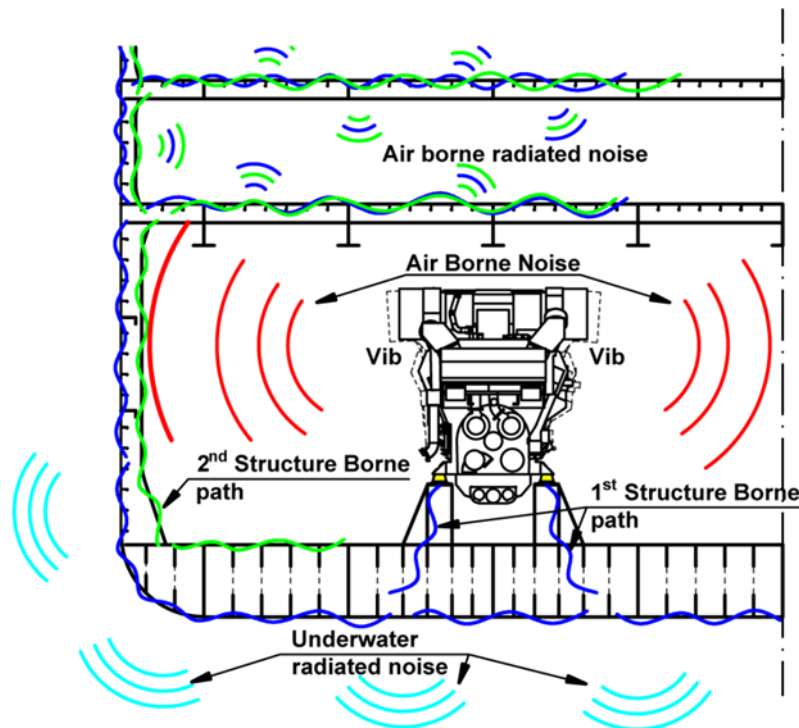

Figure 2 Engine noise and vibration source with corresponding transmission paths [1]

2.2. Noise measurement

Noise measurement is the process of quantitatively determining one or more properties of acoustic noise. In noise control studies, knowledge about the physical properties of the undesirable sound constitutes the initial step toward understanding what should be done to reduce or eliminate it. Instruments may be used to determine the magnitude of various properties of a sound as a function of time or frequency at any point in an acoustical noise field [4].

Noise measurement involves the use of an electroacoustic transducer (a microphone in air and hydrophone in water), which transforms the sound pressure or acceleration at the point of observation into a corresponding electrical signal. This electrical signal is then treated by other devices, such as filters, which select the property of interest, and the value of this property is then displayed on an indicating device such as a meter or a digital readout. For noise measurement in the air, an instrument is available for measuring the root-mean-square (RMS) value of a noise on a weighted logarithmic scale. This instrument is called a sound level meter, and a reading in decibels obtained on it is called a sound level [4].

Noise measurements are carried according to the procedures described in IMO MSC 337(91)

„Code on noise levels on board ships“ [2] which prescribes the following:

- Noise measurements shall be taken at normal service speed and at no less than 80% of the maximum continuous rating (MCR). Controllable pitch and Voith-Schneider propellers, if any, shall be in the normal seagoing position [5].
- All machinery, navigation instruments, radio and radar sets, etc., normally in use at normal seagoing condition and levels, including squelch shall operate throughout the measurement period [5].
- Measurements in spaces containing emergency diesel engine driven generators, fire pumps or other emergency equipment that would normally be run only in emergency, or for test purposes, shall be taken with the equipment operating [5].
- Mechanical ventilation, heating and air-conditioning equipment shall be in normal operation, taking into account that the capacity shall be in accordance with the design conditions [5].
- Ships fitted with bow thrusters, stabilizers, etc., may be subjected to high noise levels when this machinery is in operation. For thrusters, measurements shall be made at 40% thruster power and the ship's speed shall be appropriate for thruster operation. Measurements shall be taken at positions around such machinery when in operation and in adjacent accommodation spaces and duty stations [5].
- Measurements should not normally be taken closer than 1 m from operating machinery, or from decks, bulkheads or other large surfaces, or from air inlets. Where this is not possible, measurement shall be taken at a position midway between the machinery and adjacent reflecting surface [5].
- Regarding passenger accommodation space, measurement shall be taken in the middle of the space. The microphone shall be moved slowly horizontally and/or vertically over a distance of 1 m. Additional measurements should be performed at other points if appreciable differences, i.e. greater than 10 dB(A), in the level of sound inside the room occur, especially near the head positions of a sitting or lying person [5].
- The number of measurement cabins shall be not less than 40% of total number of cabins. Cabins which are obviously affected by noise, i.e. cabins adjacent to machinery or casings, must be considered in any case. For ships with a large number of crew cabins, such as

passenger/cruise ships, it will be acceptable to reduce the number of measurement positions [5].

2.3. Basic concepts of vibration problems in ships

All bodies possessing mass and elasticity are capable of vibration. Most engineering machines and structures experience vibration, and their design generally requires consideration of their oscillatory behavior. Oscillatory systems can be broadly characterized as linear or nonlinear. For linear systems the principle of superposition holds, and the mathematical techniques available for their treatment are well-developed. In contrast, techniques available for the analysis of nonlinear systems are less well-known, more complicated, and difficult to apply [6].

There are free and forced vibrations. Free vibrations are when a system oscillates under the action of forces inherent to the system itself, and when externally imposed forces are absent. The system under free vibration will vibrate at one or more of its natural frequencies, which are properties of the dynamical system established by its mass and stiffness distribution. Vibration that appears under the excitation of external forces is called forced vibration. If the frequency of excitation coincides with one of the natural frequencies of the system, a condition of resonance is encountered, and dangerously large oscillations may result. Vibrating systems are all subjected to damping at some degree because energy is dissipated by friction and other resistances. If the damping is small, it has very little influence on natural frequencies of the system. On the other hand, damping is of great importance in limiting the amplitude of oscillation at resonance [6].

Oscillatory motion may repeat itself regularly, as in the balance wheel of a watch. When the motion is repeated in equal intervals of time T , it is called periodic motion. The repetition T is called the period of the oscillation, and its reciprocal value is called the frequency f . The simplest form of periodic motion is harmonic motion. It can be demonstrated by a mass suspended from a light spring. If the mass is displaced from the rest position and released, it will oscillate up and down [6]. When a system is subjected to forced harmonic excitation, its vibration response takes place at the same frequency as that of the excitation. Common sources of harmonic excitation are unbalance in rotating machines, forces produced by reciprocating machines, or the motion of the machines itself. These excitations may be undesirable to equipment whose operation may be disturbed or to the safety of the structure if the large vibration amplitude develops. Resonance is to be avoided to prevent developing of

large amplitudes, and for the purpose dampers and absorbers are often used. Harmonic excitation is often encountered in engineering systems. It is commonly produced by the unbalance in rotating machinery. Harmonic excitation may be in the form of a force of displacement at some point in the system [6].

2.4. Vibration measurement

Vibration measurements are to be conducted in accordance with ISO 6954:2000. Measurement locations are to be chosen so that the assessment represents the overall vibration environment on board the ship. In cabins, vibration reading may be taken in the center of the floor area. The measurements should indicate the vibration of the deck structure. In large spaces, such as restaurants, sufficient measurements are required to define vibration profile.

In all locations, vibrations in the vertical direction are to be assessed [7]. For the ships with accommodation placed in the deck house, transverse vibration should be recorded at the front and aft end, and longitudinal vibration at the port and starboard side of the deck house at each deck level. For ships where accommodation extends over large portion of the length of the vessel, as for instance for passenger ships, the transverse vibration should be recorded at approximately 25% of the positions, evenly distributed along the ship. The longitudinal vibration should be recorded at one position on each deck [7].

The instrumentation used for the measurement shall be of an electronic type. The signal may be stored on tape, analyzed directly by means of a FFT-analyzer, or by means of PC-based equipment. The measurements shall be analyzed using FFT - techniques, and presented in the frequency domain. The results should be preferably presented as vibration velocities [7].

Measurement positions according to the Lloyd's Registers are shown in the Figure 3.

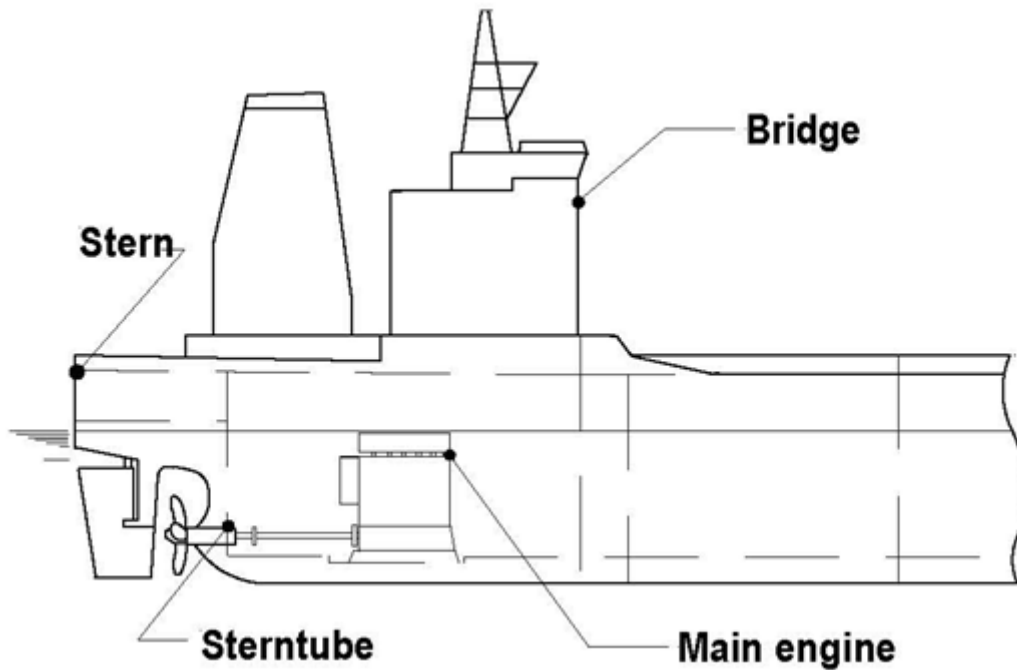

Figure 3 Measurement positions according to Lloyd's Register of Shipping [8]

2.5. Source – Path – Receiver concept

One of the approaches of controlling and better understanding of noise and vibration is the so-called Source – Path – Receiver model, Figure 4.

This theoretical model is used to examine the problem by breaking down the unit into three basic elements: the Source of noise and vibration, the conveying medium or so called Path, and the Receiver. By recognizing these elements we can see that noise and vibration can be controlled by altering any of these three elements.

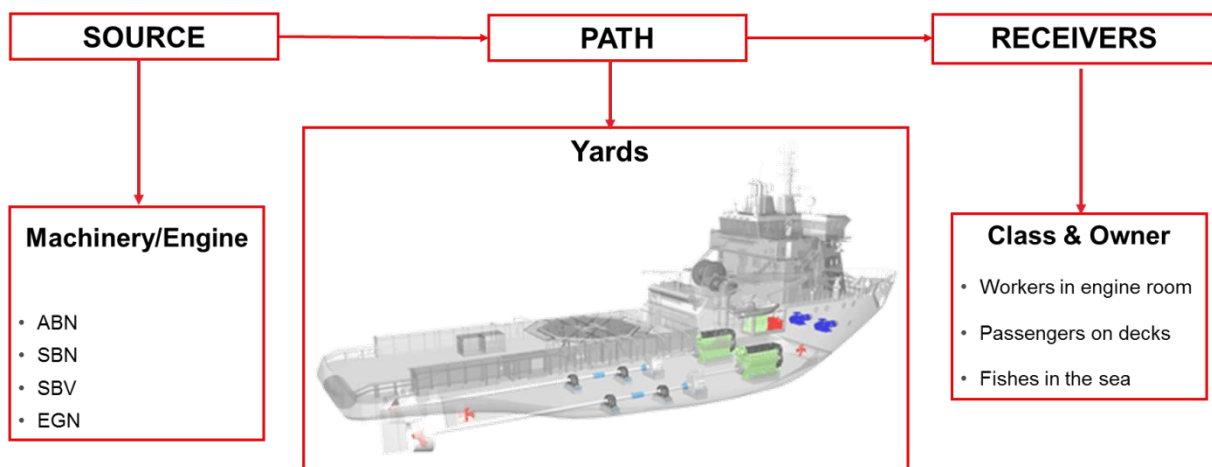

Figure 4 Source-Path-Receiver model

The greatest excitation sources on a ship are the main engine and the propeller, Figure 1. Whereas this thesis has been considered to deal with high requirement vessels, which use the four stroke engines, the excitation sources of a four stroke diesel engine and its equipment will further be reviewed.

As mentioned earlier, this master's thesis has been done within the ongoing research project lead by the Wärtsilä company related to development of a new engine type of low noise and vibration emissions. Since in the first stage of the project, and consequently in this master's thesis, the emphasis was more on vibration, and the main engine as a vibration source is further discussed in details. There are two most prominent excitation sources on board: the propeller and the prime mover. Today, prime movers on passenger ships are mostly four stroke diesel engines. For most ships, the propeller is the biggest excitation source, but because of the cruise ship's nature and how they operate during their service life, the engine as an excitation source peaks out. That means that most engines on board are also in service when cruise ships are in the harbor. In addition, it has been noted that in different areas of the ship the occurring vibration has been drastically decreased when several vibration mitigation technologies had been applied to the engine, while the propeller remained the same. All this indicates that the engine is the big source of noise and vibration problems on board, both during navigation and in harbor.

2.6. Four stroke engine as an excitation source

Shipboard machinery varies considering the ship's purpose, size, operation area etc. Although there are numerous types of machinery installed on board ships, mostly they share the same or similar concept of operation. The basic concept, regarding noise and vibration, is that certain internal forces are applied to the machinery structure which transforms them into noise and vibration excitation to the ship. The structure of the machinery basically acts like an amplifier or filter with its resonance and mode shapes, moreover its characteristics are mainly driven by minimization of weight and cost. Mathematically, the interaction between internal forces and structure can be simplified in frequency domain by a product of the two spectra: one representing excitation forces and another one representing the structure mechanical impedance. Regarding this, the first conclusion can be derived: one of the main reasons behind the increase of noise and vibration of sources nowadays is that machinery has to increase performance so excitation forces are increasing, and decrease of costs that has the

consequence of weakening the structures also increases the vibration. Internal excitations can be summarized in this way:

- Mass forces: they are mainly related to the inertia forces applied to the structure and due to the oscillating and rotating masses. If the engine is well balanced it can be expected that overall summation of forces to be nearly null. In the case the residual net force is null, there can still be unbalanced couples or structure deformation like bending and torsion transmitting forces into the hull [1].
- Metal to metal impact: in four stroke engines there are various systems like gears transmissions and valve mechanism that can lead to metal to metal impact of their parts. The first consequence is a high shock acceleration transmitted to all connected parts and the impulsive characteristic will have a high frequency content that will excite all resonances of the involved parts. Gear rattle or gear hammering due to backlash in one of these mechanisms and excitations are function of torsional vibration of connected shafts. Shafts will then transmit excitation through the bearings to the structure in form of acoustic waves till the outer surface where it will be transformed in acoustic emission (ABN). Closure of inlet and outlet valve of the cylinder head is one of the big metal to metal impacts and is immediately visible by acceleration measurement on the cylinder head. Strength of the impact is influenced by the cam profile and consequent closure velocity. Moreover the torsional vibration of the camshaft adds variability to the phenomenon, typically increasing the torsional oscillation on the opposite side of the camshaft respect to the agent gear [1].
- Fluid dynamics (turbulence, pressure pulses): all modern large bore engines are equipped by turbocharges, the compressor usually takes the air from the engine room and the turbulence interaction between rotor and stator blades create pure tone acoustic waves. Although there is always an air filter silencer in front, this is one of the strongest noise sources on the engine. If one knows the compressor speed and the number of blades it is immediately possible to recognize 1st and 2nd harmonic peaks of the spectrum. The noise propagates outside the air filter silencer but also inside the engine so it will be emitted by below, pipes and charge air cooler. Air waste gate or drain pipes of coolers produce whistles, and this phenomenon is commonly referred as jets noise. The main parameters influencing the strength are the fluid velocity and geometry of the outlet. Another characteristic excitation source is represented by fluid dynamics of liquids like oil, water and fuel. One of the representatives is the injection system. The fuel jerk pump, the injector needle lift and closure and other valves operation generate pressure pulses with high energy level and wide

frequency range. Pressure pulses excite the liquid container that starts to vibrate and emit ABN [1].

- Gas forces related to exhaust gas noise (EGN): once the combustion in the cylinder is over, the exhaust valve will open, release the gas and close. The repetitive dynamic cycle will give a characteristic pressure fluctuation of the exhaust gasses and will generate acoustic pressure that will travel outside the turbine along the ship exhaust piping and funnels. In the marine sector the noise spectrum of the exhaust gases is named exhaust gas noise (EGN). This represents one of the most challenging measurements because of high acoustic pressure and high gas temperature inside the pipes. There is no international standard that regulates the measurement methods inside the pipes and it is common to find variance between measurements of the same engine [1].

The strength of vibration source can be classified by the vibration movements of the structure and its attachment points to the ship foundation. The most common way to judge the severity of the vibration of machinery is measuring the vibration in RMS value typically in the velocity unit. When conventional vibration measurement is performed, only the vibration response is measured. This is the quickest way to get an idea of the vibration behavior of the engine or generator set, but vibration response alone, doesn't actually tell very much about the cause of the vibration and how to control it. To understand and minimize the vibration response of the system, it is necessary to analyze separately: the structure characteristics, the excitation forces and the way they both interact [1].

Rotating and oscillating masses: Crankshaft mechanism translates reciprocating linear motion into rotation, this leads immediately to the fact that there will be oscillating and rotating masses whose motion will produce inertia forces applied to the structure, Figure 5. Rotating masses will generate forces only at rotational speed (1st harmonic order by definition) and vary as function of speed with power of two, while oscillating masses also vary at multiple harmonics orders (2nd, 4th or 6th depending on the crank/stroke ratio). Rotating masses cause vertical and transversal forces, while oscillating masses cause vertical forces and torque. The combination of all cylinder forces with the sequences of firing order will act on the structure with a net force that can be null, for balanced engine or not for unbalanced. In this case, there is a net resulting force acting on the structure, and there will be direct transmission to the ship or even an amplification by a near rigid body resonance [1].

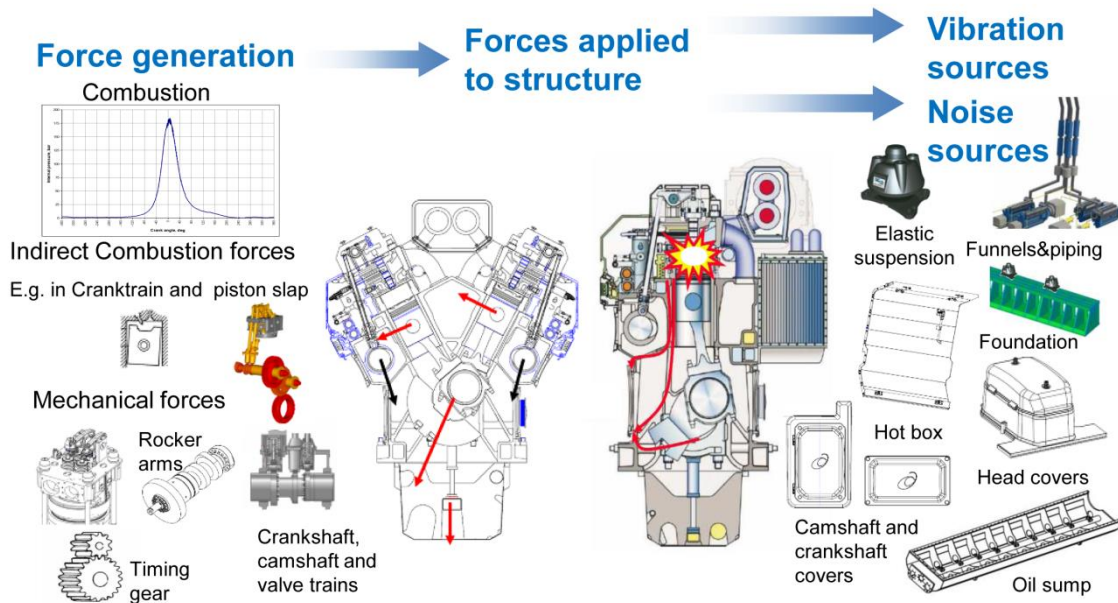

Figure 5 Excitation forces generated by the engine interacting with ship structure external emitters [1]

Gas forces (Combustion): Gas forces are the result of pressure, generated by the combustion process in the cylinder, acting on liner, piston and cylinder head inner surfaces. Following the maximum output power of engines along variable speed, gas forces are proportional to the cube of speed and at fixed speed forces are almost linear with the output power. The most relevant path in the structure is the crank mechanism, pistons press on the liner and the crankshaft on the bearings of the engine block. These forces are very high and the engine structure deforms with torsion and bending at various order. The periodicity of the combustion in a four stroke engine is two rotations of the crankshaft, that's why gas forces produce a fundamental frequency at half harmonic order and all its multiples. Gas excitations produce sensible structure vibration up to 10-20 harmonics orders, and mainly air-borne noise (ABN) and structure-borne noise (SBN) are emitted above [1].

2.7. Propeller as an excitation source

Propeller vibration is a vibration occurring on a ship hull during operation due to the uneven wake flow, cavitation, propeller ventilation, mechanical unbalance, irregularities between blades, etc. Further, a brief discussion on propeller induced vibration is given.

Cavitation is defined as the process of formation of the vapor phase of a liquid when it is subjected to reduced pressures at constant ambient temperature. Thus, it is the process of boiling in a liquid as a result of pressure reduction rather than heat addition. A liquid is said to

cavitate when vapor bubbles form and grow as a consequence of pressure reduction. When the phase transition results from hydrodynamic pressure changes, a two-phase flow composed of a liquid and its vapor is called cavitation flow [9].

It is often said that cavitation is analogous to boiling, while cavitation takes place at constant ambient temperature and boiling usually at constant ambient pressure. The phenomena experienced in cavitation attack are usually found to be a function of the type of cavitation met, its proximity to the water surface and the rate of change of the cavity's volume [10].

Vibration may be generated in the hull by either unbalanced forces or unbalanced moments, corresponding to the so-called static and dynamic balance conditions, respectively. Since the mass of the propeller lies so nearly in a single plane, any unbalanced moment will be very small. Further, vibration is not so readily generated in the hull by unbalanced moments as by unbalanced forces. Hence, ensuring a static balance of the propeller will be sufficient [9].

If in the multi-bladed propeller, Figure 6, the blades are all exactly equal and are spaced at equal angles, the three forces at the axis, P_1 , P_2 , P_3 , will have a sum equal to zero.

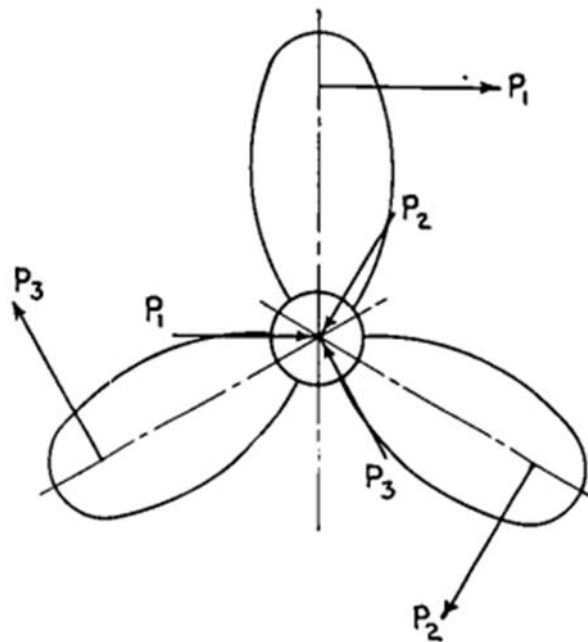

Figure 6 Propeller blade forces [9]

If, however, the blades are not exactly equal in pitch, outline, spacing or other factors, the three vectors, P_1 , P_2 , P_3 , will have a resultant, which is once per revolution force acting on the hull through the propeller bearing. Whether or not unbalance forces cause noticeable vibration

in the hull depends upon their magnitude and upon the proximity of the propeller revolutions to one of the fundamental hull frequencies [9].

3. REQUIREMENTS OF CLASSIFICATION SOCIETIES

A classification society is a non-governmental organization that establishes and maintains technical standards for the construction and operation of ships and offshore structures. The society will also validate that construction is according to these standards and carry out regular surveys in service to ensure compliance with the standards. Classification Societies set technical rules based on experience and research, confirm that designs and calculations meet these rules, survey ships and structures during the process of construction and commissioning, and periodically survey vessels to ensure that they continue to meet the rules. Classification Societies are also responsible for classing oil platforms, other offshore structures, and submarines. This survey process covers diesel engines, important shipboard pumps and other vital machinery [11].

Classification surveyors inspect ships to make sure that the ship, its components and machinery are built and maintained according to the standards required for their class [11].

Implementing the published Rules, the classification process consists of:

- A technical review of the design plans and related documents for a new vessel to verify compliance with the applicable Rules [11];
- Attendance at the construction of the vessel in the shipyard by a Classification Society surveyor(s) to verify that the vessel is constructed in accordance with the approved design plans and classification Rules [11];
- Attendance by a Classification Society surveyor(s) at the relevant production facilities that provide key components such as the steel, engine, generators and castings to verify that the component conforms to the applicable Rule requirements [11];
- Attendance by a Classification Society surveyor(s) at the sea trials and other trials relating to the vessel and its equipment prior to delivery to verify conformance with the applicable Rule requirements [11];
- Upon satisfactory completion of the above, the builder's/ship owner's request for the issuance of a class certificate will be considered by the relevant Classification Society and, if deemed satisfactory, the assignment of class may be approved and a certificate of classification issued [11];

- Once in service, the owner must submit the vessel to a clearly specified programme of periodical class surveys, carried out on board the vessel, to verify that the ship continues to meet the relevant Rule requirements for continuation of class [11].

Class Rules do not cover every piece of structure or item of equipment on board a vessel, nor do they cover operational elements. Activities which generally fall outside the scope of classification include such items as: design and manufacturing processes; choice of type and power of machinery and certain equipment; number and qualification of crew or operating personnel; form and cargo carrying capacity of the ship and maneuvering performance; hull vibrations; spare parts; life-saving appliances and maintenance equipment. These matters may however be given consideration for classification according to the type of ship or class notations assigned [11].

The surveys are to be carried out in accordance with the relevant class requirements to confirm that the condition of the hull, machinery, equipment and appliances is in compliance with the applicable Rules. Where the conditions for the maintenance of class are not complied with, class may be suspended, withdrawn or revised to a different notation, as deemed appropriate by the Society when it becomes aware of the condition [11].

Class is assigned to a vessel upon the completion of satisfactory review of the design and surveys during construction undertaken in order to verify compliance with the Rules of the Society. For existing vessels, specific procedures apply when they are being transferred from one Classification Society to another. Ships are subject to a through-life survey regime if they are to be retained in class. These surveys include the class renewal (also called “special survey”), intermediate survey, annual survey, and bottom/docking surveys of the hull. They also include tail shaft survey, boiler survey, machinery surveys and, where applicable, surveys of items associated with the maintenance of additional class notations [11].

Comfort Class was first published by DNV-GL in January 2011, and later by LR and BV, as other Classification Societies followed the DNV-GL breakthrough. Comfort Class is used for passenger's ships and also for cargo ships and it is more restrictive than Safety Class. The rules in the Comfort Class state requirements for the noise, vibration and indoor climate on board. Ships that satisfy Comfort Class requirements are more comfortable for the passengers and the workers on board, and therefore safer surrounding for workers because constant noise and vibration cause fatigue and dullness which endanger workers and can unfortunately lead to injuries.

3.1. DNV-GL Comfort Class

In the DNV-GL's Comfort Class chapter the rules state requirements for noise, vibration and indoor climate on board ships. The rules aim at attaining a ship with controlled environmental standards, and those environmental standards are divided in two groups:

- V Noise and vibration
- C Indoor climate.

In this thesis the indoor climate standards have not been analyzed. Furthermore, DNV-GL presents definitions of the main parameters determining the comfort on board [5].

Noise: audible air pressure fluctuations generated by ship machinery, systems or structure, i.e. in the frequency range 20 – 20 kHz.

Vibration: structural motion in the frequency range 1- 100 Hz.

The rules give requirements for noise and vibration related to comfort on board ships. Reference is made to national and international standards on noise and vibration criteria related to hearing damage, speech intelligibility for safety reasons, and acceptable vibration for machinery and equipment [5]. The noise and vibration criteria are divided into three groups depending on the level of comfort achieved, i.e. comfort rating number (crn) 1, 2, and 3, where crn 1 represents the highest comfort level and crn 3 represents an acceptable level of comfort. For passenger ships the given comfort rating number applies to the passenger accommodation only. The crew accommodation shall comply with minimum rating crn 3 for cargo ships [5].

DNV-GL divided noise criteria into five tables for different ships, localities and comfort standards. Regarding the type of ships they divided rules for: passenger ships, cargo ships <10,000 GT, cargo ships \geq 10,000 GT, high-speed craft and yachts – owner and guest areas.

Sound insulation indexes R'_w have been divided only based on crew and passenger areas. Acoustic insulation on board is important to preserve privacy between cabins. In this thesis, sound insulation indexes will not be analyzed in details [5].

Vibration criteria the rules have been divided for: passenger ships, cargo ships, high-speed craft and yachts – owner and guests areas. In addition, regarding vibration criteria, cargo ships have not been divided based on gross tonnage [5].

3.2. Lloyd's Register: Passenger and Crew Accommodation Comfort

These Rules set down the criteria for the assessment of the noise and vibration on ships and are applied in addition to the other relevant requirements of the Rules and Regulations for the Classification of Ships. Furthermore, Lloyd's Register presents their definitions as follows:

- Noise level: is defined as A-weighted sound pressure level measured in accordance with ISO 2923 [7].
- Vibration level: is defined by the application of ISO 6954:2000 [7].

The vibration level is defined as the overall frequency weighted RMS value of vibration during period of steady-state operation over the frequency range 1 to 80 Hz. In the sections for noise and vibration assessment criteria, Lloyd's Register states that where space is occupied by both passenger and crew, the more stringent of the relevant requirements apply unless agreed between the builder and the owner and advised to Lloyd's Register [7].

Lloyd's Register has set noise criteria for passenger ships and divided them into – maximum noise levels in dB(A), minimum air-borne sound insulation indices, R_w , crew accommodation – maximum noise levels in dB(A) (for ships < 10,000 GT, and ships > 10,000 GT) and crew work areas – maximum noise levels in dB(A) (regardless of GT) [7].

Vibration criteria have been set for passenger ships only and divided into – maximum vibration levels and crew spaces – maximum vibration levels [7].

Lloyd's Register has their own way of dividing noise and vibration criteria, similarly to DNV-GL's comfort rating numbers, LR applies acceptance numbers 1, 2 and 3.

Acceptance number 1 represents the highest level of comfort, while acceptance number 3 represents the acceptable level of comfort [7].

3.3. Bureau Veritas Comfort on board class

In the Section 1 of General Requirements, Bureau Veritas states that the Rules are divided for:

- ships of less than 1600 GT (such as fishing ships, tugs, small passenger ships excluding yachts and pleasure crafts) [12],
- ships greater than or equal to 1600 GT (such as tankers, container ships, large fishing vessels, cruise ships, ferries...) [12],
- yachts [12].

Similarly to DNV-GL's comfort rating numbers, Bureau Veritas has divided their noise and vibration criteria into: grade = 1, 2 or 3, where 1 corresponds to the most comfortable level for both passenger and crew spaces. Regarding the single amplitude peak velocity criteria BV has presented grades = 1PK, 2PK or 3PK. 1PK corresponds to the most comfortable level for both passenger and crew spaces [12].

Since all Classification Societies have similar but not entirely the same rules or division of rules, the following deviations must be noted:

- Instead of writing crn = 1, 2 or 3 for DNV-GL; Acceptance number = 1, 2 or 3 for LR; or grade = 1, 2 or 3 for BV, for all the three Classification Societies that are mentioned and for all noise or vibration levels, divisions will be further referred as comfort rating numbers 1, 2 and 3.
- On the other hand, DNV-GL divides certain spaces into "standard" and "top grade", while on the other hand LR divides them into "standard" and "top level", and BV into "standard" and "superior", so further in the text all the divisions will be referred as "standard" and "superior". For example, "Passenger cabins, standard" and "Passenger cabins, superior".

4. CORRELATION ANALYSIS OF MEASURED ENGINE RESPONSE AND PRESCRIBED LIMIT VALUES

The first task towards developing the considered techno-economic assessment is analyzing Classification Societies data regarding the noise and vibration on board. The three most essential Classification Societies regarding comfort on board are, as already mentioned, DNV-GL, Lloyd's Register and Bureau Veritas. Those three are the most prominent because they were the first to develop Comfort Class notations and therefore are most common and widespread in naval market with respect to this issue. In this section the criteria (requirements) from the mentioned Classification Societies will be reviewed and compared.

It is worth to recall how each society divided their rules.

4.1. Prescribed limit values of ship structure vibration response

Table 1 represents the rules from DNV-GL, LR and BV for maximum vibration levels, overall frequency. The table column named *Locations*, specifies locations on board ship that each Classification Society requires to be inspected, measured and rated. Division of Classification Societies and their comfort rating number crn are shown on the right. Each Classification Society has different requirements for each crn 1, 2 and 3. As mentioned before, requirements crn 1 are the strictest and they represent the highest level of comfort for the mentioned location on board, crn 2 is a medium level of comfort, and crn 3 would be an acceptable level of comfort on board ship.

Knowing this, it is evident how different Classification Societies have different principles and approaches regarding developing the rules. For example, DNV-GL is considered the strictest and it is evident that in maximum vibration levels DNV-GL requires the lowest vibration velocity of all the mentioned Classification Societies. However, DNV-GL is very minimalistic regarding division of locations on board. They have divided the whole ship into only four types of spaces: passenger cabin standard, passenger cabin superior, public spaces and open deck recreation. In their requirements DNV-GL states: "For passenger ships the given comfort rating number applies to the passenger areas only. The crew areas shall as minimum comply with crn = 3 for cargo ships" [5]. Further DNV-GL states: "The specified

vibration criteria apply to maximum level, of vertical, longitudinal and transversal vibration which shall be assessed separately” [5].

Furthermore, Lloyd’s Register has introduced all mentioned spaces on board and has added two more: work places and crew accommodation and navigation spaces [7]. On average, their vibration velocity levels are very similar to DNV-GL, Table 1.

Table 1 Maximum allowable values of vibration (mm/s) according to different Classification Societies

Location	DET NORSKE VERITAS				LLOYD'S REGISTER				BUREAU VERITAS								
	1	2	3	Average	1	2	3	Average	1	2	3	Average	1	2	3	Average	
										For ships less than 1600 GT				For ships \geq 1600 GT			
Passenger cabin, standard	1.5	2.0	3.0	2.2	1.8	2.1	2.4	2.1	3.0	3.5	4.0	3.5	2.8	3.0	3.2	3.0	
Passenger cabin, superior	1.5	1.5	2.0	1.7	1.5	1.8	2.1	1.8					1.7	2.0	2.2	2.0	
Public spaces	1.5	2.0	3.0	2.2	2.0	2.5	3.0	2.5	3.0	4.0	5.0	4.0	3.0	3.5	4.0	3.5	
Open deck recreation	2.0	2.7	3.5	2.7	2.5	3.0	3.5	3.0									
Crew cabins									3.0	3.5	4.0	3.5					
Mess rooms									3.0	4.0	5.0	4.0	3.0	3.5	4.0	3.5	
Offices									3.0	4.0	5.0	4.0	3.0	3.5	4.0	3.5	
Open public areas									4.0	6.0	6.0	5.3					
Engine control room switchboard room									4.0	6.0	6.0	5.3	4.0	5.0	6.0	5.0	
Work places					5.0	5.0	5.0	5.0	4.0	6.0	6.0	5.3	5.0	5.5	6.0	5.5	
Crew accommodation and navigation spaces					3.5	3.5	3.5	3.5									
Galleys									5.0	5.5	6.0	5.5	5.0	5.5	6.0	5.5	
Passages, halls, shops, corridors, staircases, sport rooms									3.0	4.0	5.0	4.0					
Wheelhouse									3.5	4.0	4.5	4.0	2.8	3.0	3.2	3.0	
Radio room													2.8	3.0	3.2	3.0	

Location	DET NORSKE VERITAS				LLOYD'S REGISTER				BUREAU VERITAS								
	1	2	3	Average	1	2	3	Average	1	2	3	Average	1	2	3	Average	
										For ships < than 1600 GT				For ships ≥ 1600 GT			
Hospital														2.8	3.0	3.2	3.0
Staircases and passages in crew areas														5.0	5.5	6.0	5.5
Restaurants, cafeterias														2.2	2.5	3.0	2.6
Passenger spaces - Passages, halls, shops, corridors, staircases, sport rooms														4.0	4.5	5.0	4.5
Passenger spaces - closed rooms normally manned at sea or recreational spaces where noise is generally high (discotheques)														4.0	4.5	5.0	4.5
Passenger spaces - closed rooms permanently manned at sea requiring relatively low background noise (libraries)														2.0	2.5	3.0	2.5
Passenger spaces - outside installations (swimming pools, sports decks...)														3.0	3.5	4.0	3.5

Though both DNV-GL and LR are not very prone to developing complex division of locations on board, Bureau Veritas has showed a different approach. They tend to believe that complex division, both for ship gross tonnage and locations on board are the key for establishing optimum levels of comfort on board. On the other hand, BV has the highest average level of maximum vibration velocity allowed.

These observations lead to the conclusion that DNV-GL insists on minimum possible differentiation of locations and in this way they are able to keep lowest vibration velocity levels, meaning the highest comfort level, anywhere on board. If one compares DNV-GL's *Passenger cabin standard* to *Public Spaces* it is noticeable that for each comfort rating number the maximum vibration velocity level is the same [5]. This means that the vibration velocity level, for example, in a restaurant, or a bar, must be the same as in the place where passengers sleep. It is worth noticing that vibration velocity is measured on ship trials, and in this way vibration velocity on board consists only of ship's machinery in engine room and ship's propulsion, and this requirements the noise and vibration coming from, for example, speakers in a bar or a restaurant is not included.

Similarly, Lloyd's Register keeps its requirements low, and they are not as strict as DNV-GL's. Table 1 shows that LR's *Passenger cabin superior* coincides with DNV-GL's *Passenger cabin superior* only at crn 1, where both are 1.5 mm/s, and everything else is allowed to be slightly higher [7].

Bureau Veritas is convincingly the least strict Classification Society mentioned. On average, its maximum allowed vibration velocity is higher by 30 – 50% compared to DNV-GL and LR [12]. On the other hand, the perks of distinguishing many locations may be possibility to use in manufacturer's favor the fact that not in all locations, for example, in public spaces, noise and vibration contamination is equally evident. This means that different comfort levels are necessary to maintain pleasant stay on board for example in hospital, restaurants and cafeterias and in passage and hallways. This observation can lead to different material use in different locations in order to preserve required comfort and reduce money assets. This division can be inconvenient for carrying out the measurements when spaces on board are not strictly divided or it is not clear what type of space would certain room represent. It must be pointed out that although Bureau Veritas allows higher vibration level, this does not mean that it will, in any way, damage health of the crew and passengers. Vibration velocity levels up to 2.5 mm/s are considered as excellent levels, and good levels when vibration velocity is up to

5.0 mm/s [13], Figure 7. Figure 8 shows vibration velocity assessment levels for reciprocating machinery.

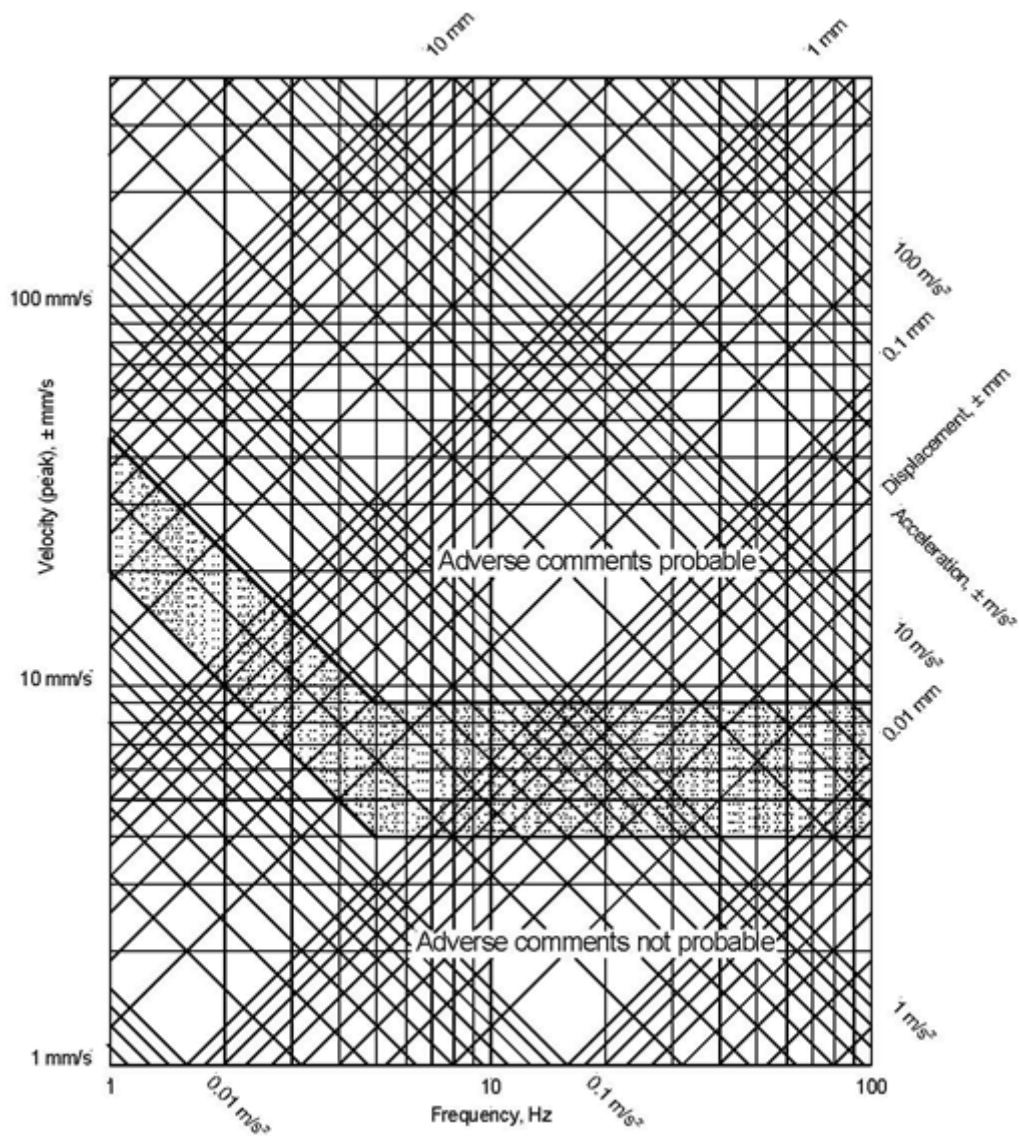

Figure 7 Vibration assessment levels for accommodation and workplace [8]

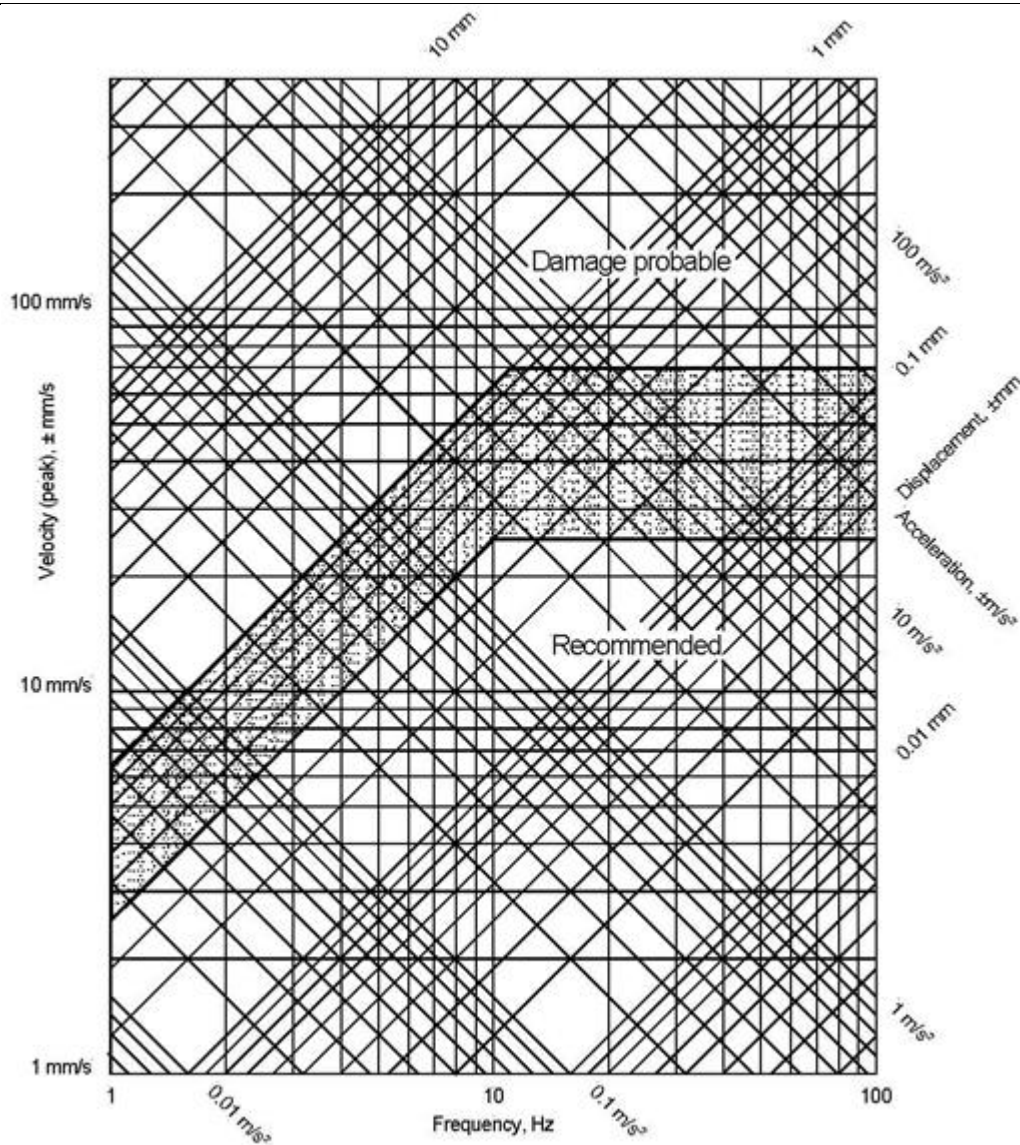

Figure 8 Assessment levels for reciprocating machinery [8]

The analyzed Classification Societies rules are the stepping stone for further analysis and developing techno-economic assessment of new marine engines. The importance of Classification Societies lies in interpretation that Classification Societies Rules represent the point of the Receiver. This means that the locations mentioned in Table 1 are actually the Receiver's perception of vibration on board. The main reason why Rules are being developed, and why owners and shipyards are coming across more and more strict comfort levels they have to obey, in order to be competitive in the market, is that the receivers require more comfortable accommodation. Therefore, the key for satisfying a customer is not only to be within the boundaries that Classification Societies require, but also to investigate the

possibilities to provide a ship, and its machinery, that have more than a satisfying level of comfort.

4.2. Measured forces on the engine

Measured data for five four stroke engines, manufactured by Wärtsilä will be presented. For confidentiality reasons and in order to protect interests of the Wärtsilä company, engines will not be referred to by their real name, but by symbolic names that have been assigned to them as follows: Engine type 1 to Engine type 5. Also due to issues of confidentiality the numbers represented in the Tables 2-6 are normalized real engine data, meaning that the ratio between numbers is real but in order to protect Wärtsilä's interests have been divided with unknown number.

All the data are measured and are obtained from Factory Acceptance Test (FAT). Factory Acceptance Test is a test done by the engine manufacturer in order to test and inspect engine specifications and see if they meet the specification specified in the project. As the name says, FAT is done in the factory, a facility where it is manufactured, but also there is Site Acceptance Test (SAT), which is performed when the engine is installed on a power plant, or in this case on a ship, in order to determine if the installation is done properly and if the engine and its surrounding machinery works well.

Tables 2-6 show measured forces on the engine. From the below histograms showed in Figure 9-Figure 13 it is evident that vibration forces F_z , measured on the engine are very wide in distribution.

Table 2 Measured forces on the Engine type 1

Engine type 1			
Engine load, %	F_x	F_y	F_z
100	1.497	0.617	1.538
100	0.435	5.258	1.287
100	0.251	5.628	1.253
100	5.040	1.547	0.532
100	0.568	0.152	1.487
85	0.408	0.169	0.776
100	0.203	2.605	0.844
100	0.179	12.367	0.756
100	0.298	6.946	0.755
100	0.295	7.734	0.556
100	0.088	7.210	0.848
100	0.107	3.582	0.459
100	0.235	3.427	0.806
85	1.481	1.390	0.250
85	0.239	2.365	0.574
100	0.913	1.683	1.143
100	3.700	1.435	0.987
85	0.152	4.676	0.808
100	1.340	0.939	0.802
100	3.297	0.217	0.269

Table 3 Measured forces on the Engine type 2

Engine type 2			
Engine load, %	F_x	F_y	F_z
85	0.134	0.920	0.621
85	0.137	0.965	0.870
85	0.229	0.335	0.094
85	0.241	0.355	0.055
85	0.197	0.566	1.027
85	0.201	0.532	1.193

Table 4 Measured forces on the Engine type 3

Engine type 3			
Engine load, %	F_x	F_y	F_z
100	10.706	2.188	1.513
100	1.754	1.129	4.020
100	4.388	1.298	1.979
100	5.090	1.144	1.719
100	7.055	2.141	1.161

Table 5 Measured forces on the Engine type 4

Engine type 4			
Engine load, %	F_x	F_y	F_z
100	0.101	0.725	0.841
100	0.388	2.022	1.022
100	0.178	3.758	0.859
100	0.380	3.714	1.315
100	0.416	3.291	0.530
100	0.252	3.153	0.786

Table 6 Measured forces on the Engine type 5

Engine type 5			
Engine load, %	F_x	F_y	F_z
100	0.088	5.842	0.105
100	0.087	3.174	0.058
85	0.053	1.117	0.083
85	0.128	4.196	0.612
85	0.122	2.377	0.472

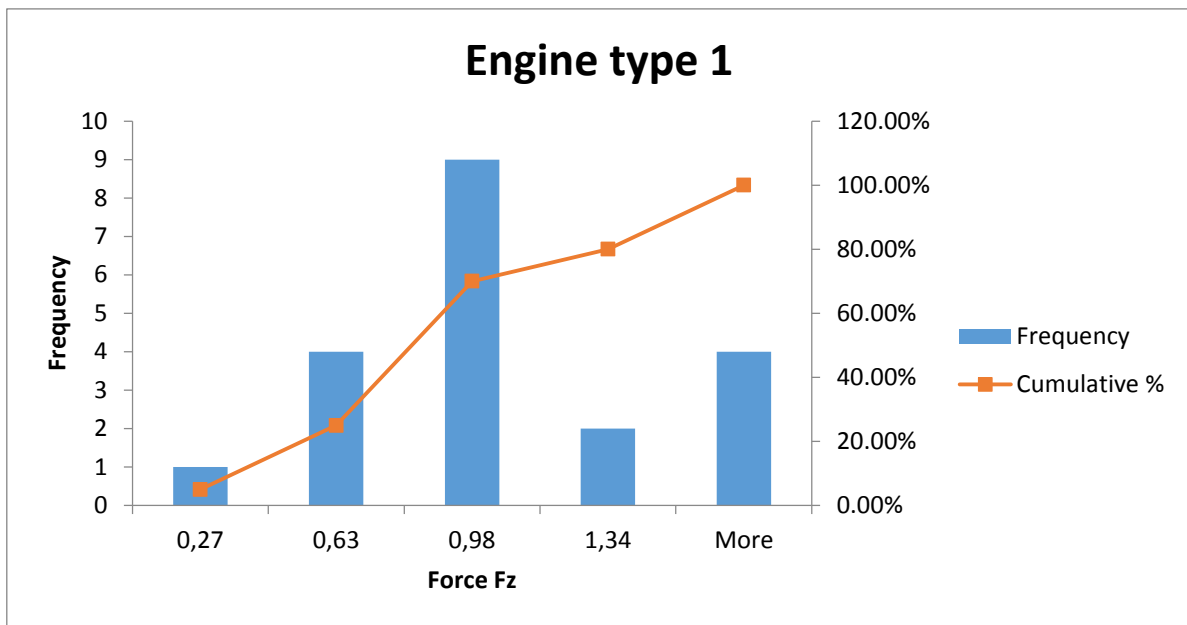

Figure 9 Force F_z distribution for Engine type 1

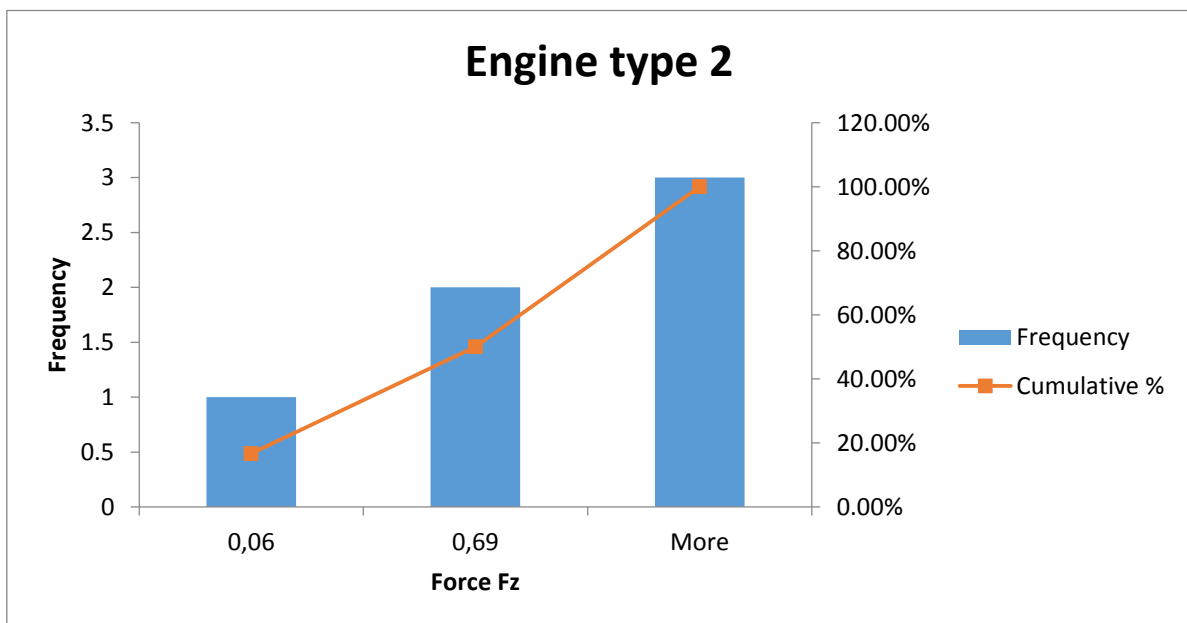

Figure 10 Force F_z distribution for Engine type 2

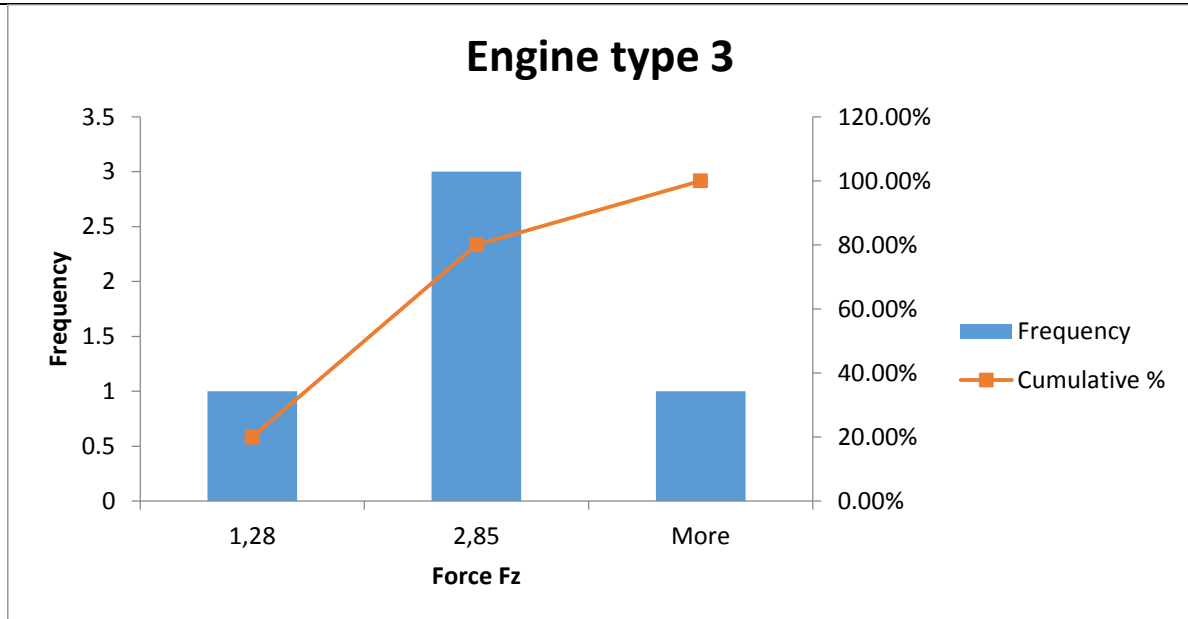

Figure 11 Force F_z distribution for Engine type 3

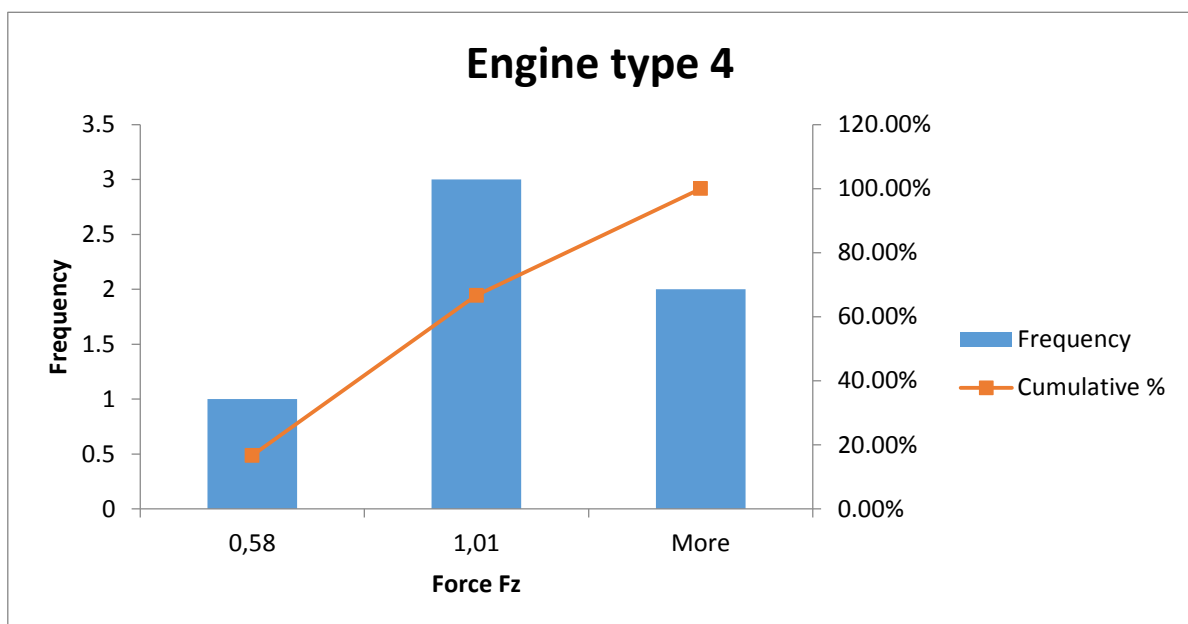

Figure 12 Force F_z distribution for Engine type 4

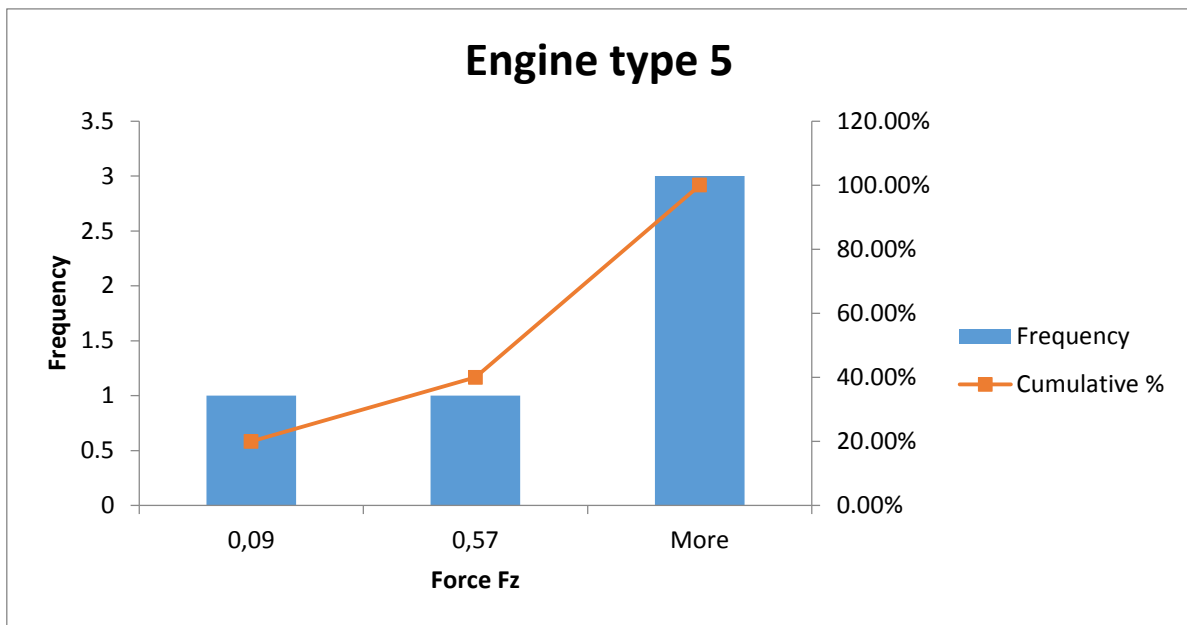

Figure 13 Force F_z distribution for Engine type 5

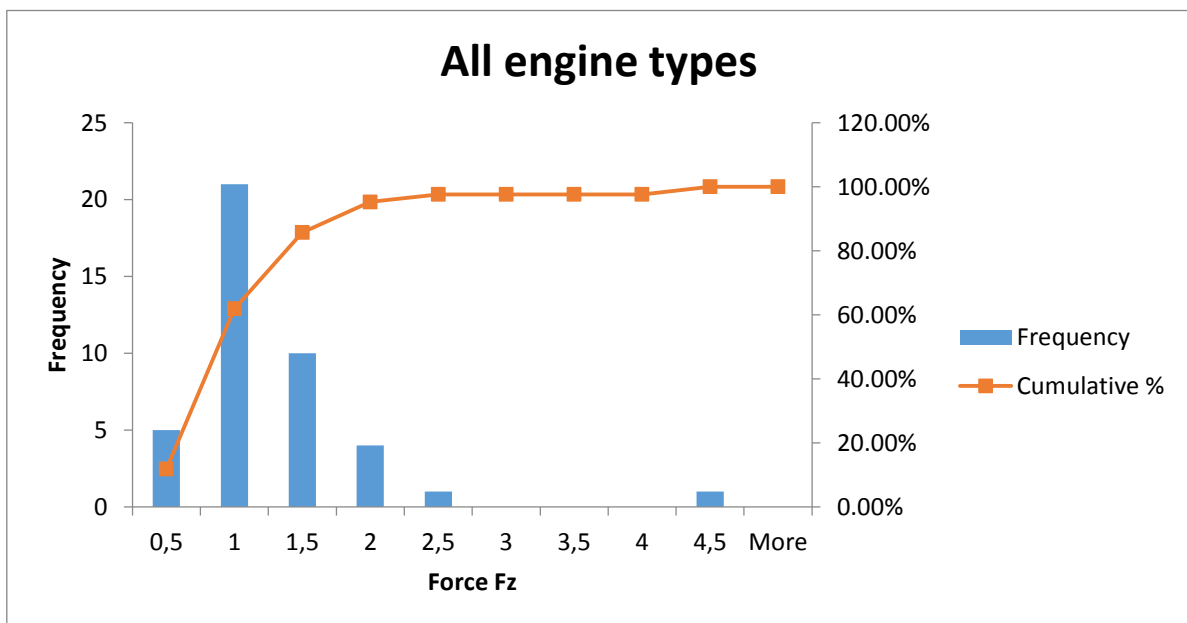

Figure 14 Force F_z distribution for all engine types

Knowing the measured forces on the engine as well as the resulting vibration at different parts of the ships, it is evident that we also know the excitation source data and vibration response that occurs at the receiver. The next step is to analyze and inspect the correlation between excitation source and the receiver, which is actually the transmission path. In this case the path is the ship, its structure and everything that vibration propagates through. Shipyards are responsible for transmission path and its quality regarding vibration propagation. In order to analyze this issue in details it is necessary to divide, explain and understand the variables of each of these three components of the Source-Path-Receiver model.

Furthermore, knowing that the engine is the excitation source, it can be said, in a very simplified way, that there are better and worse engines as regards noise and vibration that they excite. In other words, there are engines that excite more vibrations – the worse engines, and the engines that excite less vibration, therefore, the better ones. Additionally, if it would be possible to put both engines separately on the same ship, it is intuitively obvious that the good engine would excite less noise and vibration along the ship, unlike the bad engine. Based on this, it can be concluded that noise and vibration along the ship, for instance, in a passenger cabin, is the combination of the engine and the ship through which vibration propagates, as presented in Figure 15 and Figure 16.

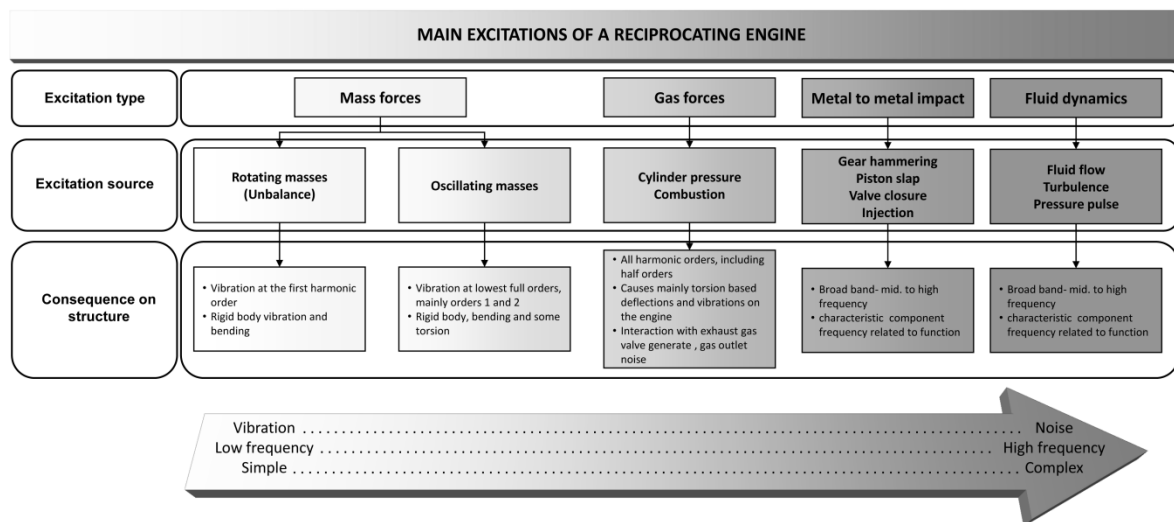

Figure 15 Main excitations of a reciprocating engine [1]

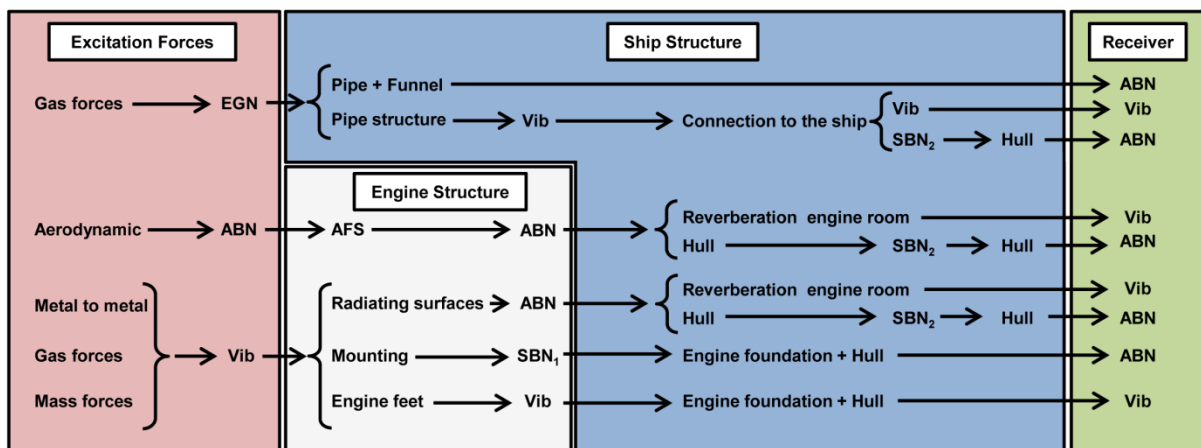

Figure 16 From source to receiver on board ship scheme [1]

On the other hand, as there could be the good and the bad engines, ship's structure could also be classified through its quality. Therefore, if the transfer path between excitation source and the receiver could be modified from good to bad quality, it is natural that in combination with different engines, noise and vibration in a passenger cabin would be different for each combination. Of course, there is not only the good or the bad quality of the engine, or the good and the bad quality of the ship. There are also a lot of different shades in between. Before explaining this any further, it must be explained and described what distinguishes a good quality engine from a bad quality one, as well as the difference in ship's structure quality.

Engines that emit less vibration are considered to be higher quality engines, and it could be said more comfortable engines. In order to keep the vibration level on board ship within the specified limits on engines with greater internal excitations, certain vibration control and reduction measures must be applied. These mitigation measures for lowering or almost cancelling vibrations that engine emits could be certain technologies applied to the engine structure or certain engine components. These technologies include as follows: resilient mountings, counterweights, balancing the engine, applying special head covers or also applying cover over whole engine, Figure 17.



Figure 17 Wärtsilä's diesel engine without and with engine cover

Resilient mountings are suspension systems made to reduce vibration propagation to ship's structure, and can be spring or rubber mountings, Figure 18.

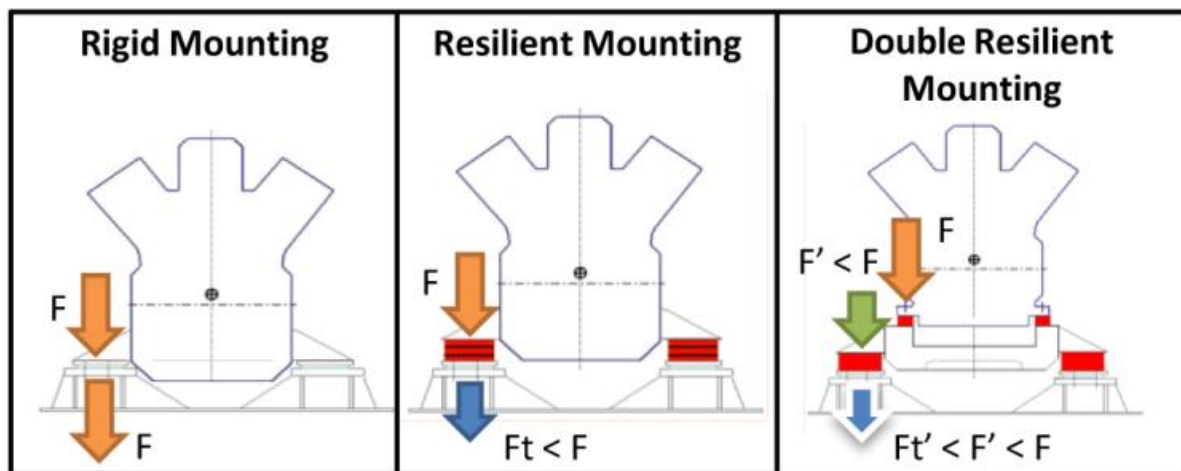

Figure 18 Typical engine mounting schemes [1]

Another possibility for controlling and reducing vibration propagation is through altering the transmission path. Higher quality can be achieved by using more material, making ship's structure more stiff and using a floating floor. Floating floor is the term that describes a floor used to reduce noise or vibration. These floors can secure a better comfort because of the sound reduction they give between the individual decks. To prevent noise –from travelling from one cabin to another an insulation solution which has the necessary rigidity, elasticity and noise reduction and absorption should be used [14].

The mentioned improvements on the ship and on the engine could also be seen as the way of mitigating vibration propagation on the source and the path. The third and most inconvenient way to reduce vibration propagation is to equip the receiver with headset, appropriate garment, working shoes, which is mandatory for the workers in the engine room and part of the crew, but it is highly inappropriate for passengers on board.

After the explanation of the concept how can the source and the transmission path vary in quality and vibration propagation, explanation of the interaction between the source and the receiver, with the transmission path in the middle can be offered.

Because of huge variety of technologies that can be implemented on the ship and the engine, there will also be huge variety of their qualities. Consequently, interactions between different ship structure quality and different engine excitation will possibly result in large variety of responses at the receiver's point. Because of this it will be very useful to develop a simple equation that will help describe responses at the receivers point when different ship's structure and engine's quality are engaged.

The equation will represent the engine as the source of excitation. Forces F_z that have been given in Tables 2-6 represent each engine, and will be specified as the maximum force on the engine e .

As already discussed, by implementing different technologies on the engine, its quality can be changed in order to mitigate and control vibration transmission. This is denoted as engine quality q_E . Quality can be represented and explained in a simplified way: if there is an engine over which no technologies have been implemented, therefore no additional vibration control and reduction has been introduced to it, its quality q_E will be equal to one, $q_E = 1.0$. In some other cases, if on the certain engine some of the technologies have been implemented, in a way that vibration response decreased for 60%, the quality q_E of the engine will be $q_E=0.4$.

The transmission path, ship S , will be considered as a transfer function. As the force F_z , measured on the engine, arises as the consequence of internal combustion, in a correlation with the transmission path, the force transforms into vibration throughout the ship.

Furthermore, the product of the ship's quality S , the type of the engine e and its quality q_E will result in vibration response at the Receiver, marked as location l . Vibration response at the location l could be seen as vibration displacement, vibration velocity at any frequency, or vibration acceleration, but in this case location l will represent vibration velocity from 5-100 Hz, that is shown in Table 1. Therefore, location l represents vibration velocity that is required by Classification Societies.

$$S \cdot e \cdot q_E = l \quad (1)$$

This equation represents interaction between the source represented as engine excitation, whether or not vibration control has been implemented upon it, the transmission path as the transfer function, which in correlation leads to vibration response at certain locations where receivers are accommodated.

The engine excitation e is known, quality of the engine q_E is represented as a percentage decrease of vibratory response (from 0.1 to 1.0), and the location l is defined as vibration velocity, and all that has to be done is to calculate the ship's transfer function S . It must be mentioned that these transfer functions S will be treated as linear which is appropriate bearing in mind harmonic nature of excitation and consequently linear propagation of vibrational energy low through the structure.

It is necessary to investigate the transfer function S in combination with different engines and their excitations that eventually leads to the same vibration velocity at certain location at the ship. To do this, the transfer function is investigated in association with the worst excitation force for each engine, the same quality of the engine, for a particular location.

The highest excitation forces for each engine are shown in Table 7.

Table 7 Maximum values of engine's excitation forces F_z

	F_z
Engine type 1	1.69
Engine type 2	1.31
Engine type 3	4.42
Engine type 4	1.45
Engine type 5	1.05

Further, to investigate the worst case of all, the worst engine quality $q_E = 1$ will be taken to consideration, as well as the most strict requirements for location passenger cabin standard, which is the DNV-GL's passenger cabin superior as shown in Table 8.

Table 8 DNV-GL standard passenger cabin requirements

DNV – GL			
Location	crn 1	crn 2	crn 3
Passenger cabin, standard	1.5 mm/s	2.0 mm/s	3.0 mm/s

$$S = \frac{l}{e \cdot q_E} \quad (2)$$

Table 9 Input data for calculating transfer functions

	F_z	l_1	l_2	l_3	q_E
Engine type 1	1.69	1.5	2.0	3.0	1
Engine type 2	1.31	1.5	2.0	3.0	1
Engine type 3	4.42	1.5	2.0	3.0	1
Engine type 4	1.45	1.5	2.0	3.0	1
Engine type 5	1.05	1.5	2.0	3.0	1

Table 10 Transfer functions

	S_1	S_2	S_3
Engine type 1	0.89	1.18	1.77
Engine type 2	1.14	1.52	2.29
Engine type 3	0.34	0.45	0.68
Engine type 4	1.04	1.38	2.07
Engine type 5	1.43	1.91	2.86

Table 10 shows transfer functions S_1 , S_2 , and S_3 for each engine type, which are necessary to satisfy DNV-GL's requirements in interaction with the highest force excitation for different comfort rating numbers 1, 2 and 3 at the location l that is the passenger cabin standard. It is understandable that for each location l on board ship there is a different transfer function, because a different path leads from the source to each location, and therefore, for each location mentioned in Classification Societies classifications its own transfer function should be calculated.

Table 11 Engine type 1, response at standard passenger cabin

Engine type 1					
DNV-GL - Passenger cabin standard					
S	q_E	e	l₁	l₂	l₃
1.77	0.1	1.69	0.3	0.2	0.15
1.18	0.2		0.6	0.4	0.3
0.89	0.3		0.9	0.6	0.45
	0.4		1.2	0.8	0.6
	0.5		1.5	1.0	0.75
	0.6		1.8	1.2	0.9
	0.7		2.1	1.4	1.05
	0.8		2.4	1.6	1.2
	0.9		2.7	1.8	1.35
	1.0		3.0	2.0	1.5

Table 12 Engine type 2, response at standard passenger cabin

Engine type 2					
DNV-GL - Passenger cabin standard					
S	q_E	e	l₁	l₂	l₃
2.29	0.1	1.31	0.3	0.2	0.15
1.52	0.2		0.6	0.4	0.3
1.14	0.3		0.9	0.6	0.45
	0.4		1.2	0.8	0.6
	0.5		1.5	1.0	0.75
	0.6		1.8	1.2	0.9
	0.7		2.1	1.4	1.05
	0.8		2.4	1.6	1.2
	0.9		2.7	1.8	1.35
	1.0		3.0	2.0	1.5

Table 13 Engine type 3, response at standard passenger cabin

Engine type 3					
DNV-GL Passenger cabin standard					
S	q_E	e	l₁	l₂	l₃
0.68	0.1	4.42	0.3	0.2	0.15
0.45	0.2		0.6	0.4	0.3
0.34	0.3		0.9	0.6	0.45
	0.4		1.2	0.8	0.6
	0.5		1.5	1.0	0.75
	0.6		1.8	1.2	0.9
	0.7		2.1	1.4	1.05
	0.8		2.4	1.6	1.2
	0.9		2.7	1.8	1.35
	1.0		3.0	2.0	1.5

Table 14 Engine type 4, response at standard passenger cabin

Engine type 4					
DNV-GL Passenger cabin standard					
S	q_E	e	l₁	l₂	l₃
2.07	0.1	1.45	0.3	0.2	0.15
1.38	0.2		0.6	0.4	0.3
1.04	0.3		0.9	0.6	0.45
	0.4		1.2	0.8	0.6
	0.5		1.5	1.0	0.75
	0.6		1.8	1.2	0.9
	0.7		2.1	1.4	1.05
	0.8		2.4	1.6	1.2
	0.9		2.7	1.8	1.35
	1.0		3.0	2.0	1.5

Table 15 Engine type 5, response at standard passenger cabin

Engine type 5					
DNV-GL - Passenger cabin standard					
S	q_E	e	l₁	l₂	l₃
2.86	0.1	1.05	0.3	0.2	0.15
1.91	0.2		0.6	0.4	0.3
1.43	0.3		0.9	0.6	0.45
	0.4		1.2	0.8	0.6
	0.5		1.5	1.0	0.75
	0.6		1.8	1.2	0.9
	0.7		2.1	1.4	1.05
	0.8		2.4	1.6	1.2
	0.9		2.7	1.8	1.35
	1.0		3.0	2.0	1.5

For further explanation, these tables can be graphically represented, as shown in Figure 19. On the X-axis, the engine quality q_E is presented from 0.1 to 1.0. The Y-axis represents vibration velocity in the mm/s. There are three parallel lines that represent maximum vibration velocity allowed in the passenger cabin for each comfort rating number 1, 2 and 3. The yellow line representing vibration velocity of 1.5 mm/s stands for comfort rating number 1, the dark blue line shows comfort rating number 2 with maximum vibration velocity of 2.0 mm/s, and, lastly, the light blue line represents comfort rating number 3 with maximum vibration velocity of 3.0 mm/s.

Besides comfort rating number lines, additional three lines are shown representing the interaction of the source and the transmission path shown, which inevitably leads to vibratory response at the observed location that is, in this case, the standard passenger cabin. Each line l_1 , l_2 and l_3 represents series of vibratory response at the standard passenger cabin. In the other words, it can be said that the gray line l_1 shows correlation between the transfer function S_1 and the engine quality q_E ($0.1 \div 1.0$), and engine excitation e .

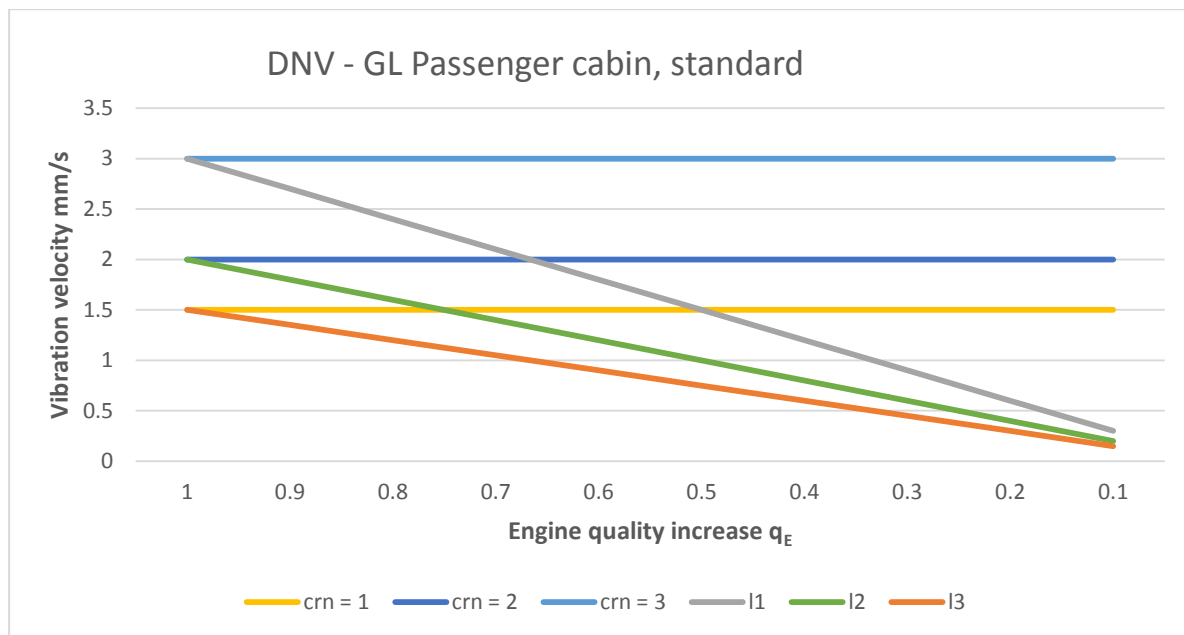

Figure 19 Vibratory response at standard passenger cabin depending on ship transfer functions

There are several things that can be concluded from the above diagram.

First, if certain vibration reduction measures are implemented on the engine in order to reduce vibratory response by approximately 35%, meaning the engine quality has been improved from $q_E=1.0$ to $q_E=0.65$, it can be noticed that with this big engine improvement a certain ship can progress in class, from crn=3 into crn=2, Figure 20.

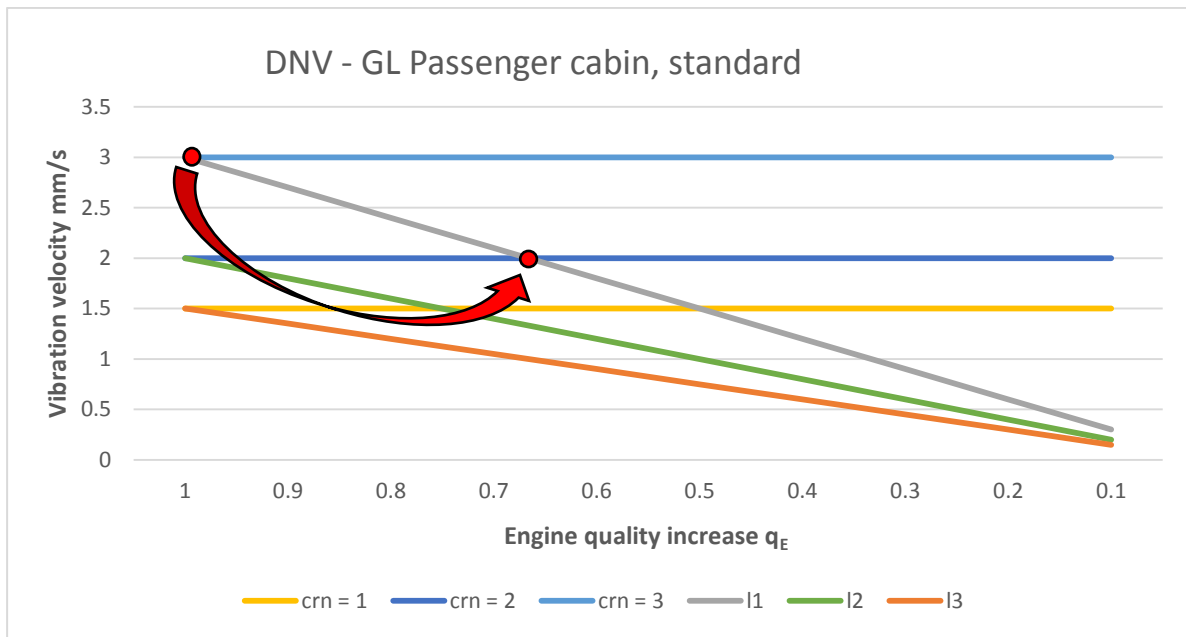

Figure 20 Progress in class from crn=3 to crn=2 due to engine improvement

Further, by implementing even more vibration reduction measures (that certain engine needs in order to reduce vibratory response), and improving the engine quality by 50%, $q_E=0.5$, the ship can progress in class from crn=3 into crn=1, and satisfy maximum allowed vibration velocity in the standard passenger cabin of 1.5 mm/s, Figure 21.

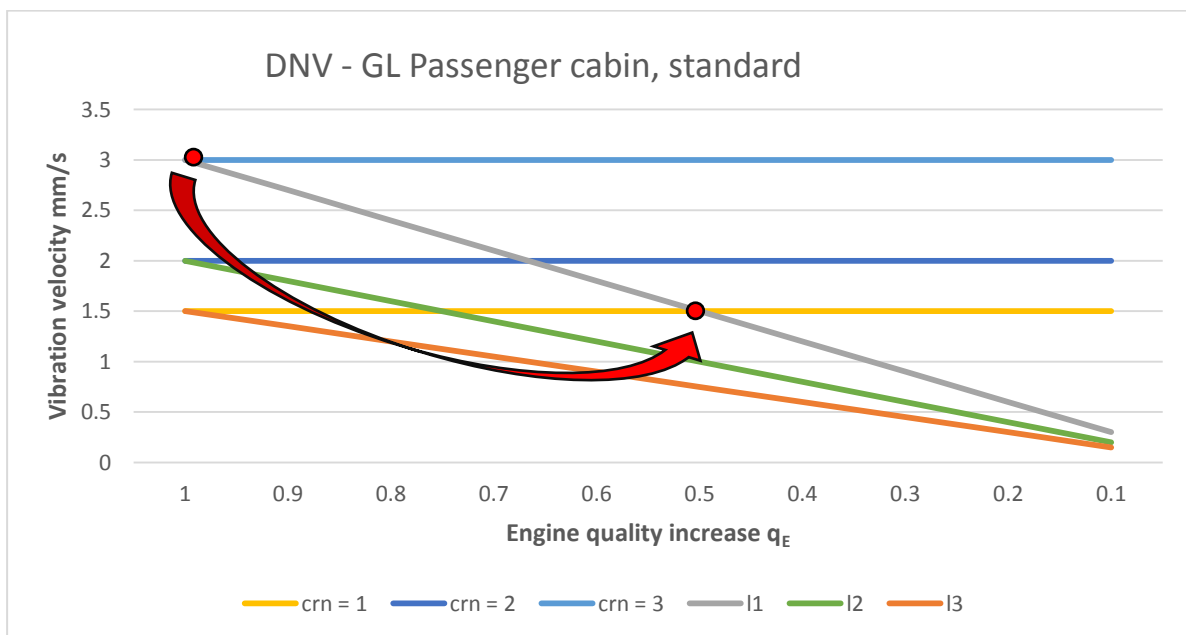

Figure 21 Progress in class from crn=3 to crn=1 due to engine improvement

In addition, if certain vibration reduction measures are implemented on the engine in order to reduce vibratory response by approximately 35%, this diagram shows that it is possible to reduce the ship's quality S in order to stay in the same class $crn=2$, Figure 22.

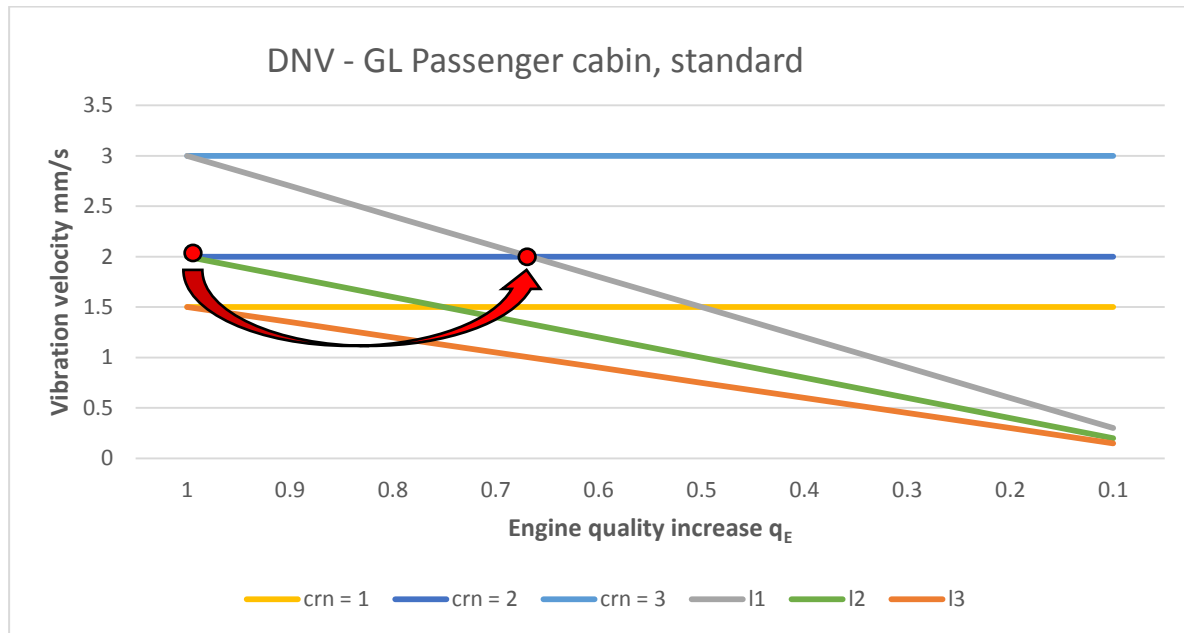

Figure 22 Sustaining the same $crn=2$ with lower ship quality and engine improvement

By improving the engine quality q_E from $q_E=1.0$ to $q_E=0.73$ it is possible to reduce the ship's quality S in order to stay in the best class, that is $crn=1$, Figure 23.

To conclude, it is obvious that it could be of great benefit for the ship owner to improve engine quality by reducing the vibration transmission through the engine foundation. First of all, if the ship could progress in class, consequently ship-owners could raise prices of cabins for providing greater comfort, which is actually beneficial only for passenger ships and cruise ships, because other types of ships will not invest in better engines if they will not financially benefit from it, particularly if they satisfy Classification Societies requirements. Secondly, theoretically it is possible to maintain the same class by reducing engine excitations and building a ship with a lower quality structure, Figure 23. This could be interesting and tempting also for the ship-owners if the ship's structure material could be decreased, but this should be subject of further analysis.

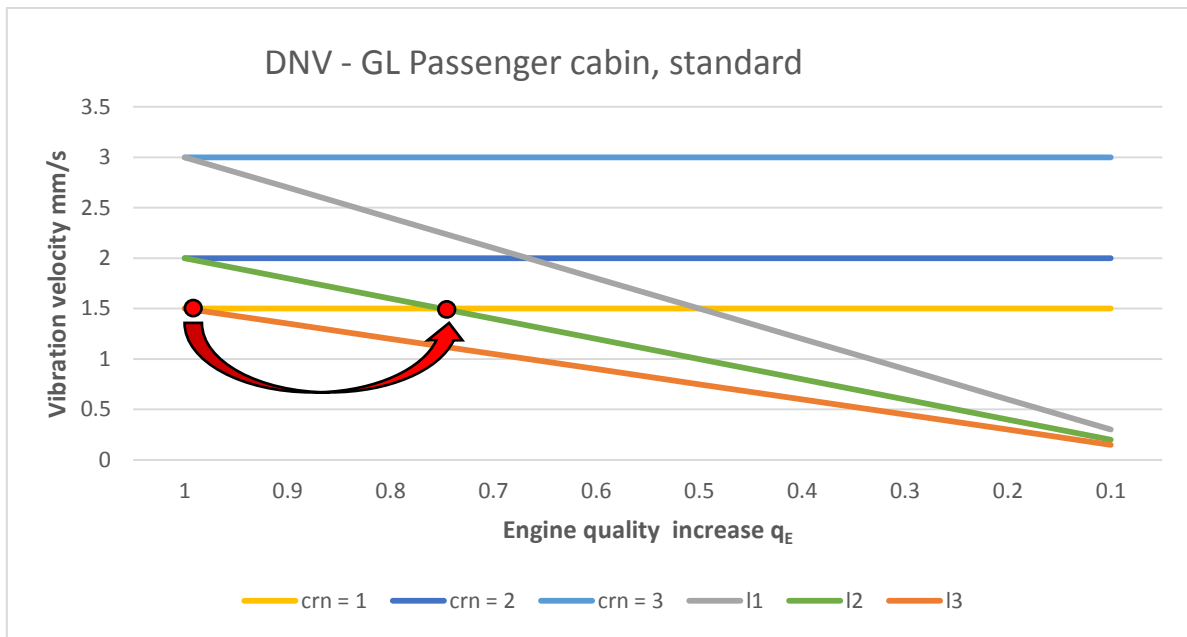

Figure 23 Sustaining the same crn=1 with lower ship quality and engine improvement

In the following tables, Tables 16-18, all three transfer functions, S_1 , S_2 and S_3 , are shown for each engine type. These transfer functions are calculated as the average of all transfer functions for each engine and specific location vibration velocity mentioned in Table 1 given by Classification Societies.

Table 16 Vibration response at the standard passenger cabin location for DNV-GL

DNV – GL									
	ET 1	ET 2	ET 3	ET 4	ET 5	q_E	l_1	l_2	l_3
e	1.69	1.31	4.42	1.45	1.05	0.1	0.29	0.21	0.16
S₁	1.70	2.19	0.65	1.99	2.74	0.2	0.58	0.41	0.33
S₂	1.21	1.56	0.46	1.42	1.96	0.3	0.86	0.62	0.49
S₃	0.96	1.24	0.37	1.12	1.55	0.4	1.15	0.82	0.65
						0.5	1.44	1.03	0.81
						0.6	1.73	1.23	0.98
						0.7	2.01	1.44	1.14
						0.8	2.30	1.64	1.30
						0.9	2.59	1.85	1.46
						1.0	2.88	2.05	1.63

Table 17 Vibration response at the standard passenger cabin location for LR

LR									
	ET 1	ET 2	ET 3	ET 4	ET 5	q_E	l₁	l₂	l₃
e	1.69	1.31	4.42	1.45	1.05	0.1	0.32	0.29	0.26
S₁	1.89	2.44	0.72	2.21	3.05	0.2	0.64	0.58	0.51
S₂	1.70	2.20	0.65	1.99	2.75	0.3	0.96	0.86	0.77
S₃	1.45	1.88	0.56	1.70	2.44	0.4	1.28	1.15	1.02
						0.5	1.60	1.44	1.28
						0.6	1.92	1.73	1.54
						0.7	2.24	2.02	1.79
						0.8	2.56	2.30	2.05
						0.9	2.88	2.59	2.30
						1.0	3.20	2.88	2.56

Table 18 Vibration response at the standard passenger cabin location for BV>1600 GT

BV > 1600 GT									
	ET 1	ET 2	ET 3	ET 4	ET 5	q_E	l₁	l₂	l₃
e	1.69	1.31	4.42	1.45	1.05	0.1	0.42	0.37	0.32
S₁	2.47	3.18	0.94	2.89	3.99	0.2	0.84	0.75	0.65
S₂	2.21	2.85	0.85	2.58	3.56	0.3	1.25	1.12	0.97
S₃	1.95	2.52	0.75	2.28	3.09	0.4	1.67	1.49	1.30
						0.5	2.09	1.87	1.62
						0.6	2.51	2.24	1.94
						0.7	2.92	2.61	2.27
						0.8	3.34	2.99	2.59
						0.9	3.76	3.36	2.92
						1.0	4.18	3.74	3.24

Engine's maximum excitations, transfer functions and response at locations showed in Table 16, Table 17 and Table 18 are graphically represented in Figure 24, Figure 25 and Figure 26. In these diagrams standard passenger cabins have been chosen for a representative location. As before, parallel lines represent comfort rating number 1, 2 and 3. As shown in Table 1, different Classification Societies have different requirements for each comfort rating number. Furthermore, lines named as l_1 , l_2 and l_3 now represent correlation between averaged transfer functions S_1 , S_2 and S_3 and the highest engine excitation e , shown in Table 7.

It is evident that Figure 19 with averaged transfer functions is very similar to Figure 24 where transfer functions calculated only for the standard passenger cabin are shown. This similarity

in diagrams can be due to very strict and low DNV-GL vibration velocity requirements for every location they propose. This means that requirements for other locations are very similar to those for the standard passenger cabin, resulting in a very similar diagram.

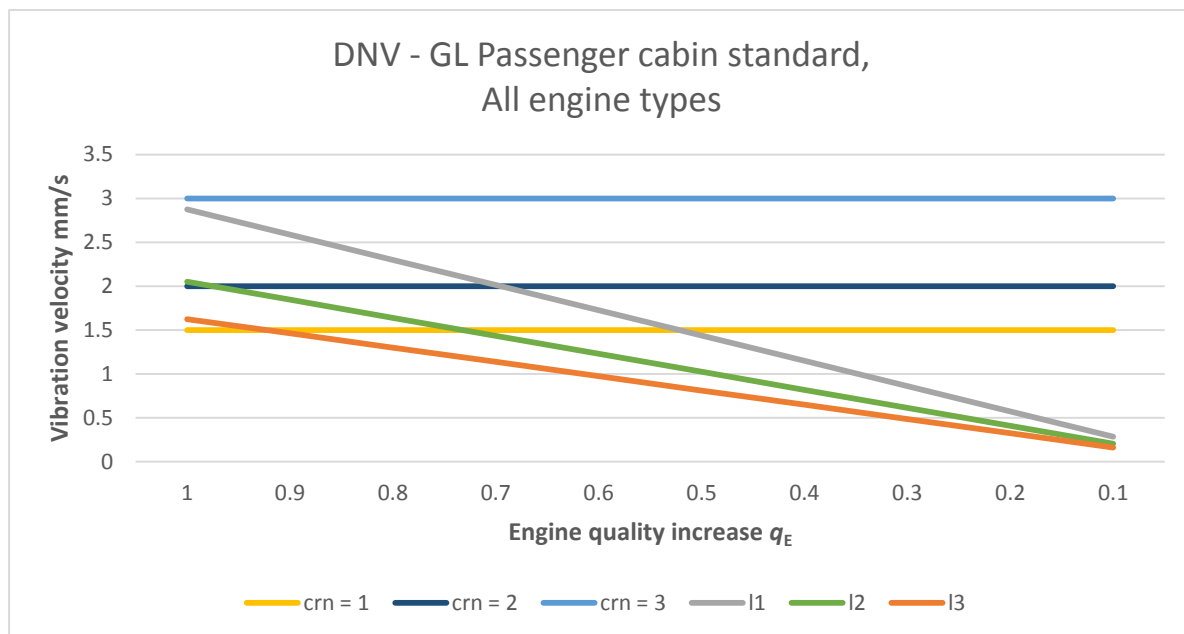

Figure 24 Vibratory response at standard passenger cabin for averaged ship transfer functions, DNV-GL

Responses l_1 , l_2 and l_3 from Lloyd's Register Classification Society are quite higher than the requirements for Lloyd's Register's a standard passenger cabin in the range from $q_E = 1.0$ to $q_E = 0.75$. This results from a greater difference between their requirements for a standard passenger cabin and other requirements for given locations specified in Table 1 for Lloyd's Register, which are from 30% to 50% higher than the lowest requirement given, that is comfort rating number 1 for a standard passenger cabin. Consequently, this difference is visible in the diagram Figure 25.

Responses l_1 , l_2 and l_3 from Bureau Veritas also would not fulfill Bureau Veritas's requirements for standard passenger cabin from $q_E = 1.0$ to $q_E = 0.77$, Figure 26, where the line named l_1 does not satisfy even comfort rating number 3 for a standard passenger cabin.

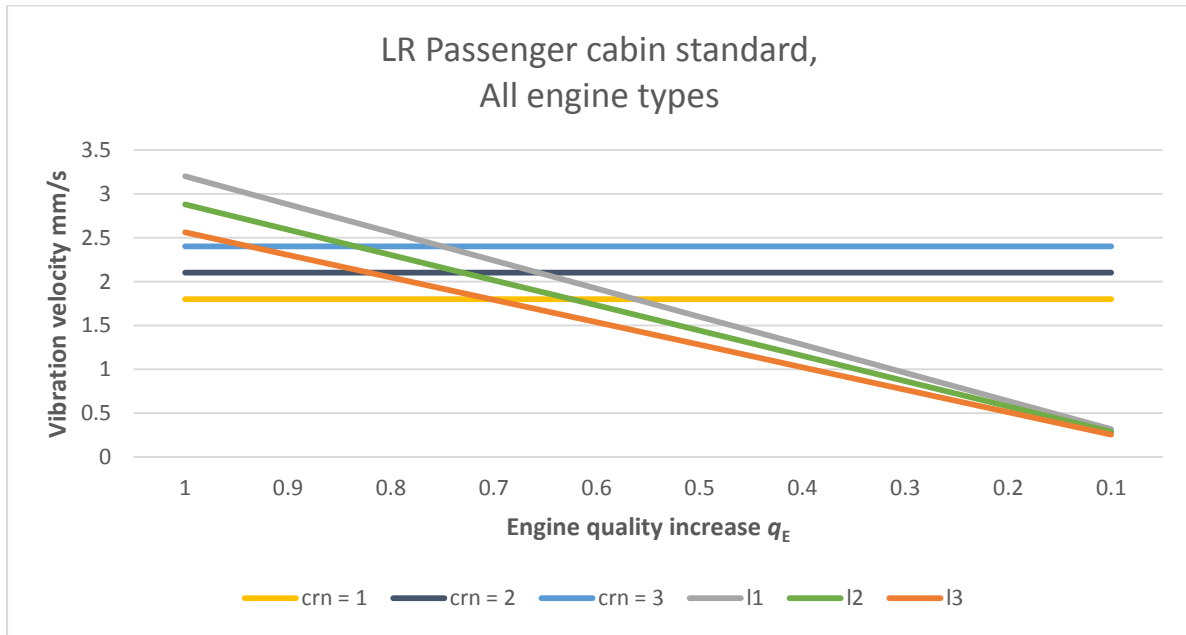

Figure 25 Vibratory response at standard passenger cabin for averaged ship transfer functions, LR

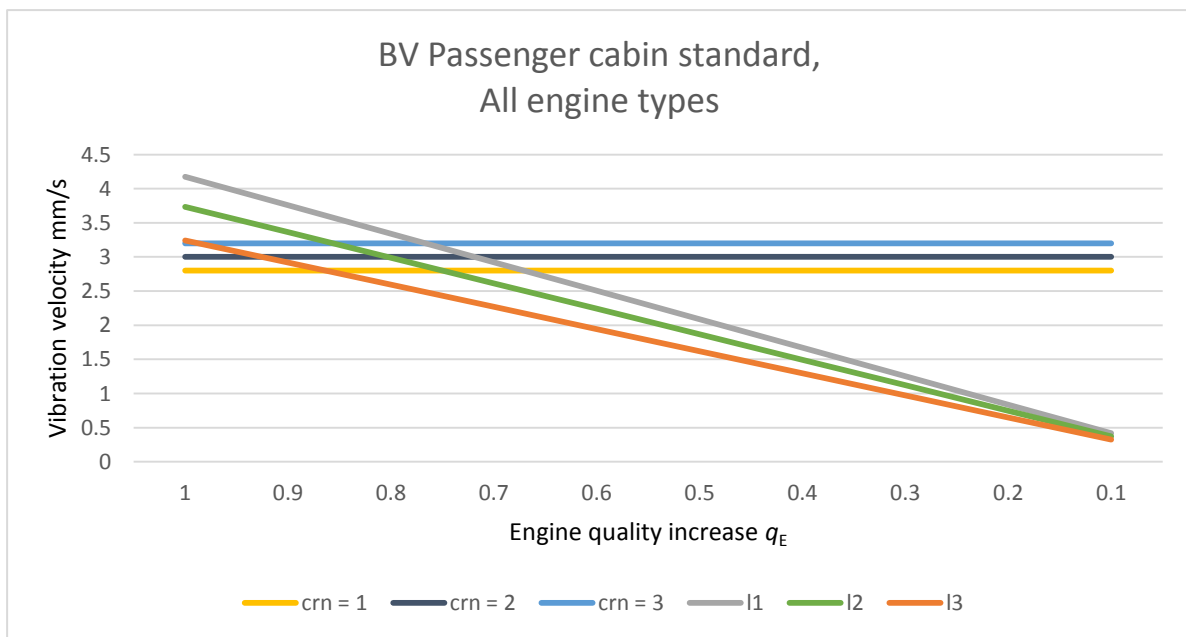

Figure 26 Vibratory response at standard passenger cabin for averaged ship transfer functions, BV

5. TECHNO - ECONOMIC ASSESSMENT

Techno – economic assessment is based on the relation between vibration levels in the passenger cabins of cruise ships induced by the engine and cabin prices. Analysis is made on the MSC Cruises fleet, consisting of MSC Musica (2006), MSC Orchestra (2007), MSC Poesia (2008), and MSC Magnifica (2010), all being sister ships.

The MSC Poesia is the third Musica – a class cruise ship built in 2008 and operated by MSC Cruises. The vessel has a 1,268 passenger cabins which can accommodate 2,536 passengers in double occupancy, served by approximately 990 crew members. 65% of her passenger cabins have a balcony whereas a further 14% having a window. Inside cabins constitute 21% of the total number of cabins. The majority of cabins have one or two extra pull-down bunks so its actual maximum passenger capacity is considerably higher than 2,536. There are only 18 suites, all located forward on deck 15 [15].

General characteristics of the MSC Musica-class cruise fleet is shown in Table 19.

Table 19 General characteristics of MSC Musica fleet

General characteristics [15]	
Class and type:	Musica - class cruise ship
Tonnage:	92,409 GT
Length:	293.83 m
Beam:	32.31 m
No. of decks:	16
Speed:	23 knots (43 km/h)
Capacity:	2,550 passengers
Crew:	987

5.1. The decks

The total number of decks on MSC Poesia – class cruises is 16, while 12 of them are intended for passengers, and the rest is meant for crew and machinery. The cruise line distinguishes the different categories (Inside, Oceanview, Balcony) into subcategories (Bella, Fantastica,

Wellness and Aurea), Table 20. The only difference in the subcategories is usually location on the ship [16].

The first deck intended for passengers is the fifth deck, named Petrarca, Figure 27, that includes: restaurant, bar, reception, passenger cabins (Oceanview 2 and Interior 1), and medical center. Staterooms on the fifth deck are located from the half middle up to the beginning of the bow.

The sixth deck, named Dante, Figure 28, and the seventh deck, named Manzoni, are mainly intended for entertainment, and consists of restaurants, bars, shops, poker rooms, meeting centers and a theater which lodges spread up to the seventh deck,

Figure 29.

The difference between the fifth, sixth and the seventh deck is that the seventh deck is first to incorporate aft space for passenger entertainment. On the contrary, aft space is not plotted into deck plans that are available on the used web page [16].

The eighth deck, named Tasso, of MSC Poesia, Figure 30, is the first deck that consists only of passenger staterooms. Passenger cabins located on this deck fall into the following categories: Balcony Bella, Oceanview Bella, Oceanview Fantastica, and Inside Bella staterooms. The aft part of the MSC Poesia, and its sister ships, consists of Balcony Bella and Inside Bella staterooms. The middle part accommodates of Oceanview Bella and Oceanview Fantastica staterooms. Oceanview Bella, which is one grade lower than Oceanview Fantastica, is located behind lifeboats lines, so the possibility of obstructed view is high. Oceanview Fantastica, on the contrary, is located where obstructed view from lifeboats is not possible. As the aft, the bow on the eighth deck consists of Balcony Bella, Inside Bella, and only two Oceanview Fantastica handicap accessible staterooms.

The bow of the Ungaretti deck, the ninth one, Figure 31, consists of Balcony Fantastica and Inside Bella cabins, as the middle zone of this deck. The aft is a little bit different. As it can be seen in the Figure 31, the aft is here divided into an extremely aft part, consisting of eight Balcony Fantastica staterooms, and side aft cabins, that are Balcony Bella cabins. As always up to this deck, inside cabins fall into the Inside Bella category.

The Carducci deck, the tenth deck, Figure 32, includes Balcony Fantastica and Inside Bella staterooms.

The D'Annunzio deck, the eleventh deck, Figure 33, has upgraded stateroom categories on the aft and bow inside cabins, leveling up from Inside Bella to Inside Fantastica.

The twelfth deck, named Leopardi, Figure 34, is the last deck consisting only of passenger cabins and on this floor, Interior Wellness, Balcony Aurea and Balcony Wellness appear on MSC Poesia for the first time. The aft has Balcony Fantastica and Inside Fantastica staterooms. Its middle part consists of only few inside cabins, classified as Inside Fantastica, Balcony Fantastica, Balcony Aurea and Balcony Wellness cabins. The bow has Inside Fantastica, Inside Wellness staterooms, and outer cabins are again of the Balcony Fantastica and Balcony Wellness category.

The thirteenth deck, named Foscolo, Figure 35, is also intended only for passenger's entertainment and leisure, but this time not only restaurants and buffets are incorporated, but the biggest area is reserved for pools, baths and spa.

The 14th deck's, Pascoli deck's bow, Figure 36, consists of outer cabins categorized as Balcony Aurea, and inside cabins categorized as Inside Fantastica cabins. The rest of the deck is again intended for entertainment and leisure.

The 15th deck, named Alfieri, Figure 37, stands out as regards passengers comfort, because, twenty-five cabins are located on the bow and 18 of them are suites, categorized as Suites Aurea, the remaining five are Balcony Aurea, of which one is handicapped-accessible. The two inner cabins are of the Inside Fantastica grade.

The last deck, the sixteenth, named Sport, Figure 38, is, as the name implies, only aimed for sport and recreation.

It can be easily concluded that with rising of the decks, prices of the cabins increase.

There are several problems with each part of the ship: the bow, the middle and the aft. Splashing of the waves, especially during rough seas, cause most of the noise problems for passengers located at the bow of the ship. In addition, mostly noise, but also vibration problems on the bow occurs when dropping and pulling the anchor, and when using bow thrusters. Noise and vibration problems associated with anchor and bow thrusters are uncomfortable and annoying but cannot be specified as severe problems hence they are usually used for a very short period of time. The anchor is used only when mooring the ship, and bow thrusters are mostly used when maneuvering, entering or exiting the harbor, etc.

Passengers mostly agree that the middle of the ship is the best part of the ship to choose a stateroom on. Only a part of the middle zone is contaminated by noise and vibration due to the machinery, and the rest of this zone is a comfortable area. It does not have a problem with swelling, and passengers are satisfied with this location because it is close to the elevator and stairs. Obstructed view is possible only on the eighth deck.

The aft is, by far, the most contaminated part of the ship regarding noise and vibration. On the other hand, extremely aft cabins have the widest balconies, regardless to the category they fall into (Balcony Bella or Fantastica). Passengers on board are mesmerized by the wake field they can witness from their personal balconies. Side cabins on the aft may be in the same category as the extremely aft cabins, but they do not have the same area of the balconies. Interior aft cabins are the least comfortable cabins due to their interior position, which prevents the possibility of any kind of a porthole or window, and also due to the fact that they are located on the aft part of the ship, which suffers from severe noise and vibration problems. Further, the cabin prices are reviewed regarding the noise and vibration contamination and it is investigated which are the most prominent sources of noise and vibration at particular locations.

5.2. The Aft

From 8th to 9th deck

The aft part of the 8th Tasso deck consists of thirty side Balcony Bella cabins, as well as the eight Balcony Bella cabins placed on the extreme aft. Seventeen inside staterooms are all at the Inside Bella level. The difference in prices between the staterooms on the aft from the 8th to the 9th deck is seen on the extremely aft staterooms. These eight cabins range from the Balcony Bella to the Balcony Fantastica level prices.

From 9th to 10th deck

On the 10th deck, cabins continue to level up from the Balcony Bella level to the Balcony Fantastica level, but this time the cabins level up are side aft cabins. Inside cabins remain at the same level and the same number as the cabin on the previous deck.

From 10th to 11th deck

The difference between the Carducci deck and the D'Annunzio deck is seen only in the inside cabins that range from the Inside Bella to Inside Fantastica level. The only inside cabin that does not differ is the 11204 cabin, placed in the corner near the elevator. This one remains at the same level, the Inside Bella level, as on the previous deck.

From 11th to 12th deck

On the 12th Leopardi deck, the arrangement of the aft cabins changes. Thirty side aft cabins are of the same Balcony Fantastica level as on the 11th D'Annunzio deck. The inside staterooms also remain at the same level as on the previous deck, but this time their number

has increased, going from sixteen Inside Fantastica level cabins to eighteen, plus one inside cabin that changed from Inside Bella to Inside Fantastica, which results in nineteen Inside Fantastica cabins on the 12th deck.

5.3. The Middle

From 8th to 9th deck

Going from the Tasso to the Ungaretti deck all side middle cabins that are labeled as Oceanview Bella and Oceanview Fantastica cabins on the 8th deck, change into Balcony Fantastica level on the 9th deck. Also, as the lifeboats are removed from the deck, a lot of space is cleared up for the cabins. So, on the 9th deck first middle inside cabins appear. These ten inside cabins are all Inside Bella cabins.

From 9th to 10th deck

On the Carducci deck, outside middle cabins are of the same Balcony Fantastica level as on the previous floor as well as inside cabins are of the same Inside Bella level. The only difference is in the increase in number of the inside cabins, from ten on the Ungaretti deck to fourteen on the Carducci deck.

From 10th to 11th deck

As in the previous example, middle outside and inside cabins remain at the same level as before, Balcony Fantastica for the outside cabins, and Inside Bella for the inside cabins, and the only difference again is in the increase in number of inside cabins, going from fourteen to twenty inside cabins.

From 11th to 12th deck

On the last deck, the 12th Leopardi deck, consisting entirely of passenger cabins, there is a significant difference in passenger cabins. First, nine cabins on each side, closest to the aft, remain Balcony Fantastica cabins. Next six cabins, on each side of the ship, are first on board Balcony Wellness cabins. From there onwards, thirty seven cabins on each side are labeled as Balcony Aurea cabins. Inside cabins have changed from the Inside Bella to the Inside Fantastica level, but the number of inside cabins decreased from twenty to twelve cabins.

5.4. The Bow

From 8th to 9th deck

On the bow of the 8th deck of MSC Poesia, there are fifteen cabins at each side labeled as Balcony Bella cabins, and at the front of that cabin row, there are two cabins (one at each side of the ship) labeled as Oceanview Fantastica cabins, both intended for passengers with disability. There are thirteen inside cabins labeled as Inside Bella. Two of the twelve cabins on the starboard side are also intended for passengers with disability.

On the 9th Ungaretti deck, all outside cabins convert to Balcony Fantastica cabins, two front remaining cabins for passengers with disability. Also, on the 9th deck there are twenty outside staterooms at each side of the ship, whereas on the 8th deck, there are sixteen cabins at each side. As regards inside cabins, all twelve remain Inside Bella staterooms, still with two handicapped-accessible staterooms.

From 9th to 10th deck

There is no difference in the outside cabins between the 9th and the 10th deck. Cabins on both decks are classified as Balcony Fantastica cabins, and there is no difference in the number of cabins. As regards inside staterooms, there is only the increase in number of the cabins, going from twelve to thirty one.

From 10th to 11th deck

As before, there is no difference between the outside cabins. On the other hand, inside cabins change from Inside Bella to Inside Fantastica cabins, and also their number increases from thirty one to thirty four.

From 11th to 12th deck

Similarly to the aft and middle part of the Leopardi deck, there is a significant difference in the arrangement and classification of the cabins, going from the D'Annunzio to the Leopardi deck. First five outside cabins, close to the middle of the ship, are labeled as Balcony Wellness cabins. In addition, the remaining eight on each side are classified as Balcony Fantastica cabins. The inside cabins are also mixed. Fifteen of them are classified as Inside Fantastica staterooms, and the remaining three as Inside Wellness cabins.

5.5. Cabin prices

With the selected destination, length of the journey, and also time of the year, cabin prices vary, but mostly their ratio is constant. Journey selected for cabin prices analyses is an eight-day tour “Greek Islands and Oriental Mediterranean from Venice”, and the route includes the following ports: Venezia - Bari - Katakolon - Mykonos - Pireo - Atene - Saranda - Dubrovnik – Venezia [16].

Cabin prices showed in Table 20 are quoted per person, for the whole journey. Most of the cabins are for two people, but some interior cabins are meant for up to four people, with two regular beds, and two additional bunk beds, while some are intended for three people with one additional bunk bed.

It is worth mentioning that in the further analysis the 5th, 14th and 15th decks have not been considered because their position and cabin distribution are not representative for the analysis based on vibration disturbances that could origin from the engine.

Table 20 Cabin prices on MSC Poesia [16]

	Bella	Fantastica	Wellness	Aurea
Interior	689.00 EUR	739.00 EUR	959.00 EUR	
Oceanview	839.00 EUR	939.00 EUR	1,159.00 EUR	
Balcony	989.00 EUR	1,089.00 EUR	1,309.00 EUR	1,489.00 EUR
Suite				1,739.00 EUR

Going from the 8th to 9th deck, an increase in prices is shown on extreme aft cabins, as these eight cabins differ in types from Balcony Bella, that is 15,824.00€, to eight Balcony Fantastica cabins, that is 17,424.00€, resulting in the increase of 1600.00€. Another difference is seen in the inside cabins rates. On the 8th deck, there are seventeen Inside Bella cabins, cabins with two additional bunk beds, which results in four people per cabin, that is 46,852.00€. On the 9th deck there are fifteen Interior Bella cabins with two additional bunk beds, 41,340.00€, and one Inside Bella cabin with only one additional bunk bed, that is 2,067.00€. Surprisingly, this small change results in a decrease of the cost of the all aft cabins by 1,845.00€, regardless of the increase by 1600.00€ on the extremely aft cabins.

Furthermore, as regards cabins in the middle of the 8th deck there are eighty eight of Oceanview Bella cabins with two additional bunk beds, that is 295,328.00€, and sixteen Oceanview Bella cabins with only one additional bunk bed, that is 40,272.00€. There are no inside cabins in the middle part of the ship on 8th deck. Total cost of the 8th deck middle cabins are 335,600.00€. On the middle of the 9th deck there are one hundred and four Balcony Bella cabins, and there are ten Interior Fantastica cabins with one additional bunk bed. Therefore, regarding one hundred and four outside cabins, going from the 8th deck, that is 359,336.00€, to the 9th deck that is 226,512.00€, there is again a significant decrease in the total sum because Oceanview cabins have possibility of increasing the number of people per cabin by introducing bunk beds. With adding cost of ten Inside Bella cabins with only one additional bunk bed, 22,170.00€, that is in total 248,682.00€ for the middle cabins on the Ungaretti deck.

The bow of the 8th deck consists of thirty Balcony Bella cabins, that is 59,340.00€, two Oceanview Fantastica staterooms with one additional bunk bed, that is three people per cabin, resulting in 3,756.00€, and thirteen Interior Bella cabins, with one additional bunk bed, resulting in 26,871.00€. The total sum of the MSC Poesia 8th deck bow cabins is 89,967.00€. On the 9th deck there is a significant increase in space resulting in forty Balcony Bella cabins, that amounts to 87,120.00€, ten Interior Bella cabins with one bunk bed, that is 20,670.00€, and two Interior Bella cabins with two bunk beds, that is 5,512.00€. The total sum of is 117,658.00€. Compared to the 8th deck, the 9th bow has the increase of 23,335.00€.

Going from the 9th to 10th deck, all side aft cabins change from the Balcony Bella to the Balcony Fantastica cabin type. In other words, the change in cabin type for thirty cabins results in price increase of total 6,000.00 €. On the 10th deck, at the aft, there are thirteen inside Interior Bella cabins with two bunk beds, that is 35,828.00€. The total price of the aft of the Carducci deck is 123,026.00€. Compared to the Ungaretti deck, there is an increase of 5,368.00€. This increase results only from increasing number of interior cabins, and increasing number of people per cabin. Regarding the middle of the Carducci deck, the only difference again is an increased number of interior cabins, eleven of them are Interior Bella cabins with one bunk bed, that is 22,737.00€, and three of Interior Bella cabins are with two bunk beds, that is 8,268.00€. The total price of the middle Carducci deck is 257,517.00€, that is the increase, compared to the 9th deck, of 8835.00€. The bow of the Carducci deck has the same number of Balcony Fantastica cabins, but there is again a significant increase in the number of interior cabins: nine of them are Interior Bella with one additional bed, that is

18,603.00€, and twenty two of the Interior Bella cabins are with two bunk beds, 60,632.00€. Going from the 9th to 10th deck, the total increase in price is 48,697.00€.

On the 11th floor, interior cabins change from Interior Bella passenger cabins into Interior Fantastica cabins for the first time. On the aft of the D'Annunzio deck, there is change from Interior Bella cabins into Interior Fantastica cabins, but in this case there is only one additional bunk bed per room. It means that sixteen Interior Fantastica cabins for three people cost 35,472.00€. There is also one Interior Bella cabin for four people on the aft of the 11th deck, for 2,756.00€. Because the number of people per cabin decreased, there is also a decrease in the total price for the bow of the D'Annunzio deck of 2,034.00€. The middle part has increased in cabins by four of the Interior Bella cabins with four people per room, and two of the Interior Bella cabins of three people per room. The outside cabins are the same as on the 10th deck. This results in an increase of 104,582.00€. The bow of the D'Annunzio deck, like the Carducci deck, consists of thirty eight Balcony Fantastica cabins, but this time all the inside cabins are Interior Fantastica cabins: nineteen of them are for four people per room, that is 56,164.00€, and fifteen of them are for three people per room, that is 33,255.00€. The price of the D'Annunzio bow is 126,958.00€, which shows a significant decrease of 39,397.00€.

The 12th Leopardi floor, differs almost completely compared to previous decks. There are no extremely aft cabins, and for the first time there are Balcony Wellness, Balcony Aurea and Interior Wellness cabins. The arrangement that remains the same is from the aft to the funnel, and first twenty seven bow cabins: outside cabins are Balcony Fantastica cabins, and interior ones are the Oceanview Fantastica cabins. The aft part of the Leopardi deck consists of thirty Balcony Bella cabins, that is 59,340.00€, eighteen Inside Fantastica cabins for three people, that is 39,906.00€, and one Interior Fantastica for four people, which is 2956.00€. The total sum of the aft is 102,202.00€. That is again a decrease of 18,101.00€.

The middle part has eighteen Balcony Bella cabins, that is 35,604.00€, twelve Balcony Wellness cabins 31,416.00€, seventy four Balcony Aurea cabins, that is 220,372.00€, and 10 Interior Fantastica cabins for three people 22,170.00 €, and two Interior Fantastica for four people 5912.00€. The total sum is 315,474.00€. A decrease again, of 46,620.00€.

The bow consists of ten Balcony Wellness cabins, that is 26,180.00€, sixteen Balcony Bella cabins, that is 31,648.00€, nine Interior Fantastica cabins for four people 26,604.00€, six Interior fantastica for three people 13,302.00€. The total price of the bow is 71,554.00€ that also shows a decrease of 48,749.00€.

Although with the higher position of the cabin cabin prices increase, the total sum generally decreases. The reason for this is the decrease of passengers per cabin. Interior and Oceanview cabins are the cheaper ones and they also accommodate more passengers per cabin. This enviably results in higher profit. This leads to the conclusion that cabins positioned at the lower deck can be a good way to make a bigger profit if only their comfort would be increased.

Cabins on the lower decks suffer from a greater vibration problem than the upper ones, especially on the aft part where the propeller makes great disturbance. It is easily noticed that the extremely aft cabins change the most as the deck goes higher. It is especially odd that the mentioned extreme aft cabins have bigger balconies than the rest of them on board, and they are still graded, on the 8th deck, as the only Balcony Bella level, which is the most modest of all the Balcony cabins. This is obviously due to severe vibration problems that are caused by the propeller, which makes impossible to charge a higher price for the current level of comfort in these cabins. As regards the aft part, passengers complain about severe vibration problem on the aft part up to the 10th deck.

Vibrations caused by the engine occur around the funnel. Passengers are mostly not greatly disturbed by these vibrations, which is evident from the Figures 30-33 which shows that cabins around the funnel do not differ from other cabins in the middle part of the ship. Engine vibrations cause disturbances on the lower decks, from the fifth to the seventh deck. These decks consist of spaces for leisure and socializing among passengers on board. Because the passenger's cabins on the fifth deck are located from the middle of the ship up to the bow, Figure 27, it can be concluded that any other part of the fifth deck has been avoided due to the engine or propeller vibration. It has been reported that engines make great disturbances in the restaurants, where passengers complained that they could not eat peacefully because their plates shook severely.

If only the aft part of the ship, from the 8th to the 10th deck, is considered for improvement, it is evident that by upgrading comfort for at least one cabin category level could result in a much higher profit. The middle will not be considered because there is no clear characteristic change in cabin category that can be linked to vibration problems, and the bow will not be considered because neither splashing of the waves nor heave motions of the ship in rough seas cannot be decreased.

If the aft cabins on the 8th deck are upgraded by one level, from Balcony Bella to Balcony Fantastica, that sum for these thirty eight cabins would increase from 75,164.00€ to

82,764.00€, that is an increase by 7,600.00€. Furthermore, if on the same deck, seventeen of Interior Bella cabins that accommodate four people per cabin, change into Interior Fantastica cabins, accommodating also four people per cabin, that would be an increase of 3,400.00€. The total increase on the 8th deck would be 11,000.00€.

If the same principle applies to the 9th deck, i.e. if thirty side aft cabins change from Balcony Bella to Balcony Fantastica, it would lead to an increase of 6,000.00€. Fifteen interior cabins would change from Interior Bella to Interior Fantastica, with four people per cabin, with the increase of 3,000.00€. Most probably, comfort of the eight extremely aft cabins could not meet acceptable comfort requirements for the Balcony Wellness level on this deck, therefore it will be left unchanged. The total increase on the 9th deck would be 9,000.00€.

Similarly to the 9th deck, side aft cabins on the 10th deck would probably not meet acceptable comfort requirements for the Balcony Wellness level, but on the other hand, extremely aft cabins could be upgraded to the Balcony Wellness level due to their biggest balconies along the ship. Therefore, there would be an upgrade of the eight Balcony Fantastica cabins into Balcony Wellness cabins, with the increase of 3,520.00€. Likewise, inside cabins would change from Interior Bella for four people (fifteen cabins) to Interior Fantastica for four people, with the increase of 3,000.00€. One Interior Bella cabin for three people, too, would change into Interior Fantastica for three people, with the increase of 50.00€. The total increase for this floor would be 6,570.00€.

If possible changes could apply, the ship could benefit up to 26,570.00€ per eight-day cruise, which will be the same as if the space for additional thirty nine passengers accommodated in Interior Bella cabins is increased. In addition, prices for Interior cabins would increase up to 9.3%, while prices for Balcony cabins would increase from 8.3% to 9.0%. Keeping in mind that this fleet consists of four ships this change could bring up to 106,280.00€ profit for each eight-day cruise.

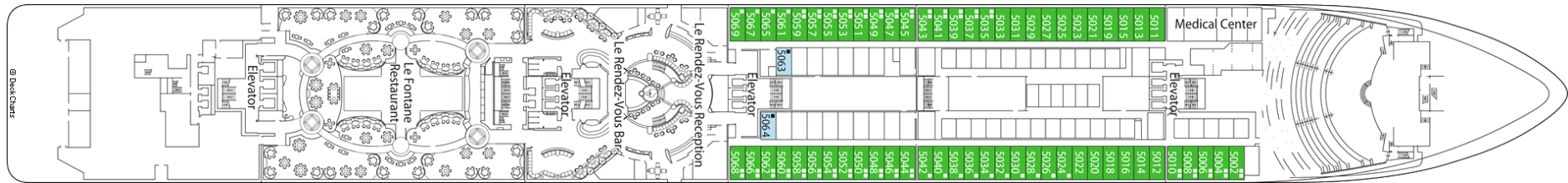

Figure 27 5TH deck Petrarca on MSC Poesia [16]

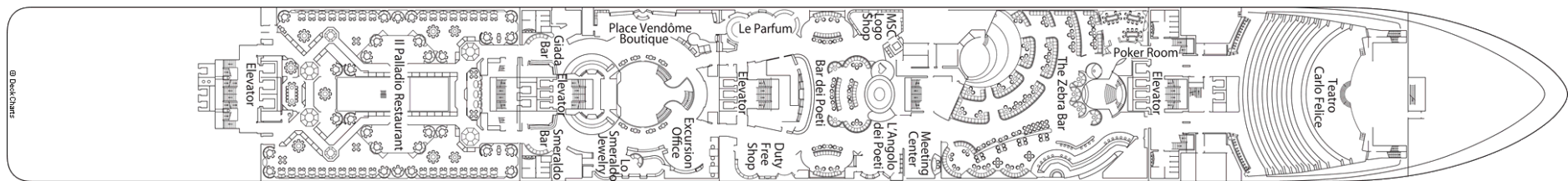

Figure 28 6TH deck Dante on MSC Poesia [16]

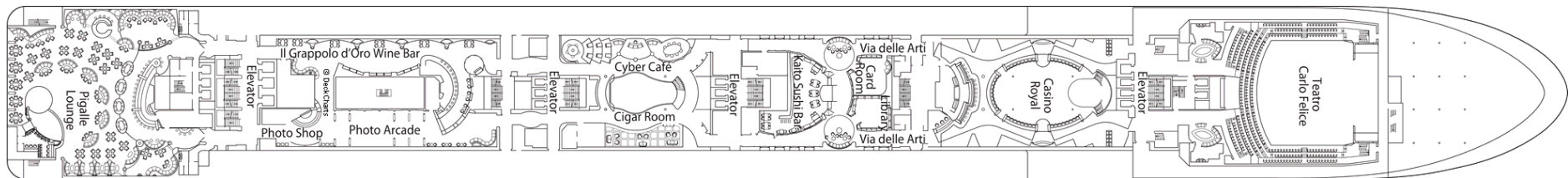

Figure 29 7TH deck Manzoni on MSC Poesia [16]

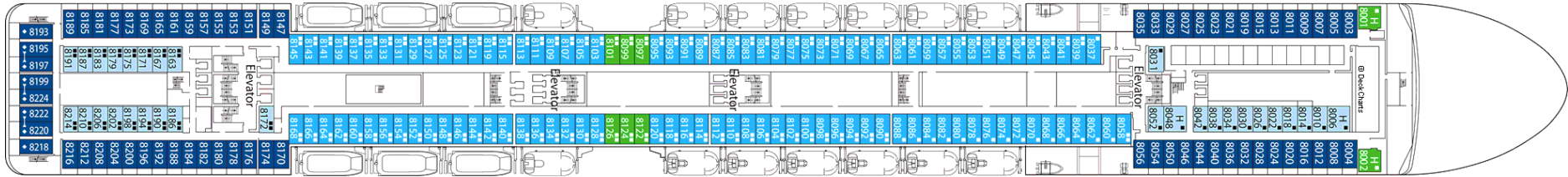

Figure 30 8TH deck Tasso on MSC Poesia [16]

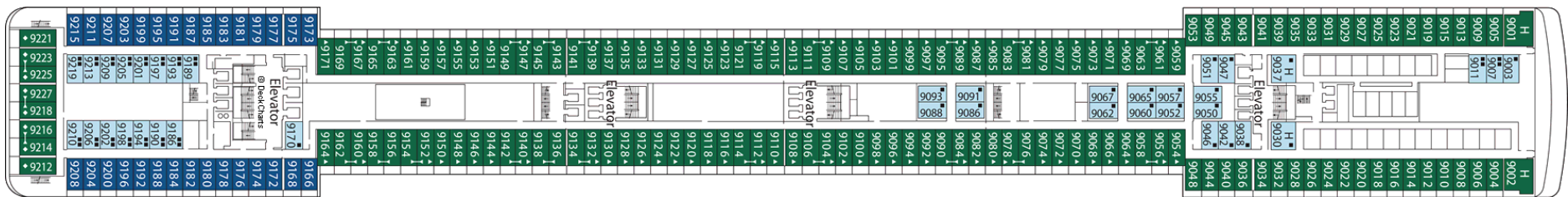

Figure 31 9TH deck Ungaretti on MSC Poesia [16]

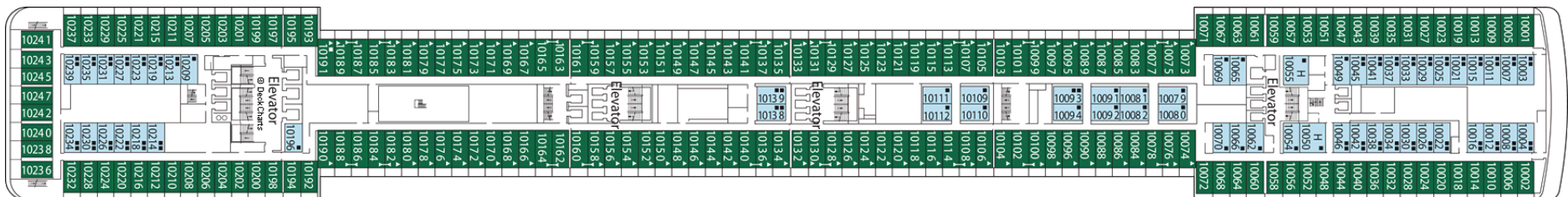

Figure 32 10TH deck Carducci on MSC Poesia [16]

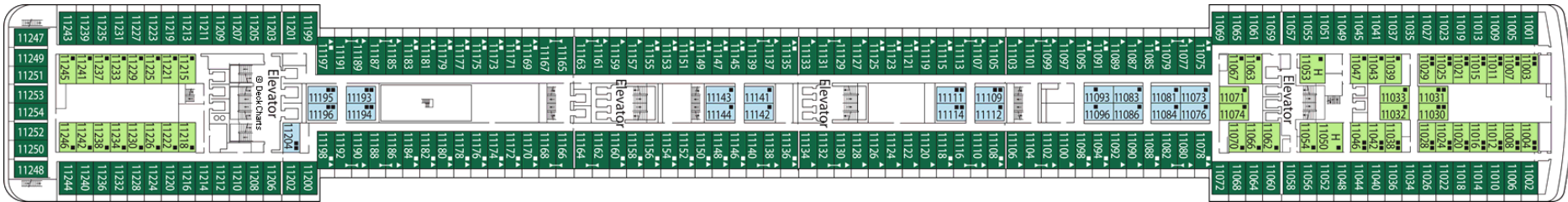

Figure 33 11TH deck D'Annunzio on MSC Poesia [16]

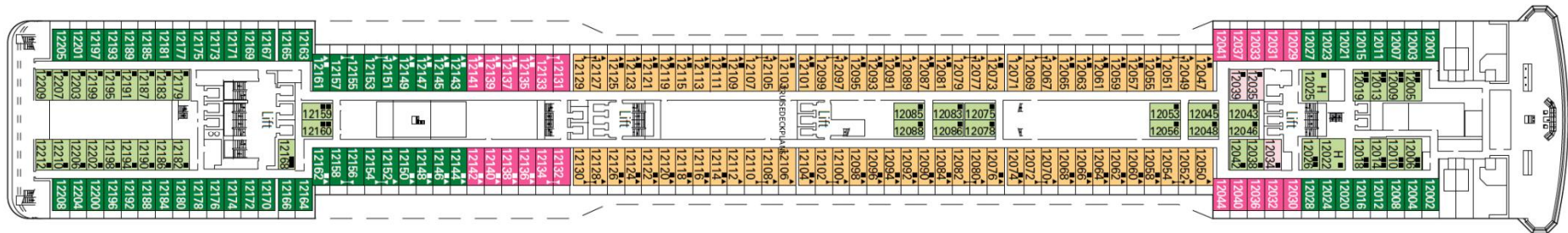

Figure 34 12TH deck Leopardi on MSC Poesia [16]

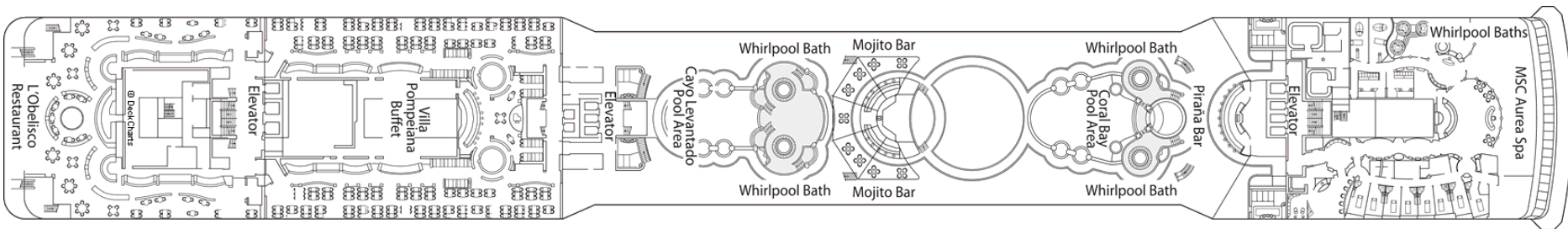

Figure 35 13TH deck Foscolo on MSC Poesia [16]

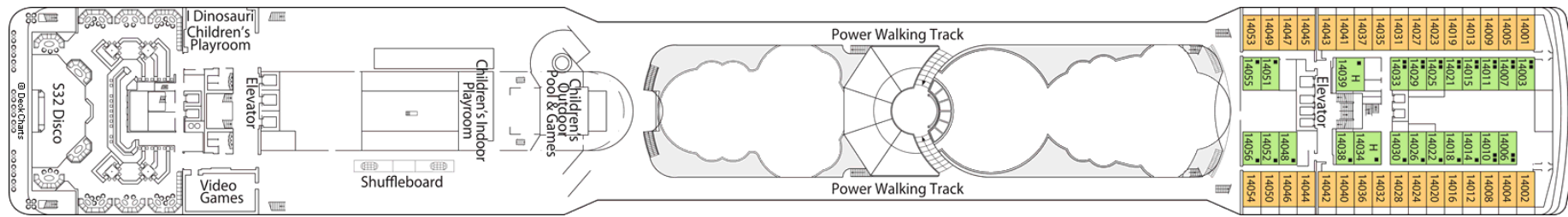

Figure 36 14TH deck Pascoli on MSC Poesia [16]



Figure 37 15TH deck Alfieri on MSC Poesia [16]



Figure 38 16TH deck Sport on MSC Poesia [16]

6. ANALYSIS OF NOISE INFLUENCING PARAMETERS

As earlier described, initial part of the project, and therefore this thesis was mostly related to vibration, but not noise. However, these phenomena are regularly considered together, or at least they are closely linked. Therefore, in a second project stage, the noise will be of primary interest. As a basis for that, dominant noise influencing parameters on board should be identified, which will help to both designer and engine producer to achieve suitable solution. Hence, the simplified box model simulating single ship compartment with a noise source is generated, and some parameters like distance from the walls, wall thickness and insulation materials are varied to get insight into their influence on compartmental noise. The general commercial software Designer-NOISE, based on hybrid Statistical Energy Analysis is used, as described below in details.

6.1. Outline of the used software

Designer-NOISE is a software program designed to allow for quick and accurate predictions of noise levels on surface ships and other stiffened plate structures. Octave-band and overall A-weighted noise levels are calculated based on sound propagation from machinery, propeller, and wave slap sources via air-borne and structure-borne paths. Causes of noise in any compartment can be evaluated, and various treatment options can be explored, including resiliently mounting equipment, adding absorptive insulation and/or damping materials, etc. [17].

In the short term, Designer-NOISE can allow shipbuilders and designers to produce quieter vessels more effectively and efficiently. Noise can be analyzed early in the design process to help with the overall design of the vessel, equipment selection, and treatment requirements. Furthermore, modifications to the vessel that occur as the design progresses can be assessed from a noise perspective, allowing for a more complete cost benefit analysis. In the long run, ship operators and crews will benefit as a result of lower noise levels leading to increased productivity, lower fatigue, and a reduced risk of long-term hearing damage, leading to lower cost of ownership. Designer-NOISE uses a 3-D Graphical User Interface to facilitate rapid model creation and entry of model parameters. The 3-D Graphical User Interface provides the user with a more intuitive and realistic representation of the vessel, and allows for improved 'bookkeeping' as compared with spreadsheet methods. The core solver uses a hybrid

Statistical Energy Analysis (SEA) approach to predict spreading of vibration throughout the vessel. Architectural acoustic methods are used to predict the spreading of airborne noise [17].

6.2. Model description

Noise propagation modes are processed on a simple model that consists of two compartments: one of them contains the noise source, simulating the engine, and the other compartment serves for noise analysis (compartment of interest). Compartment that contains the noise source hereinafter will be referred to as the compartment 1, and the observed compartment will be referred as compartment 2.

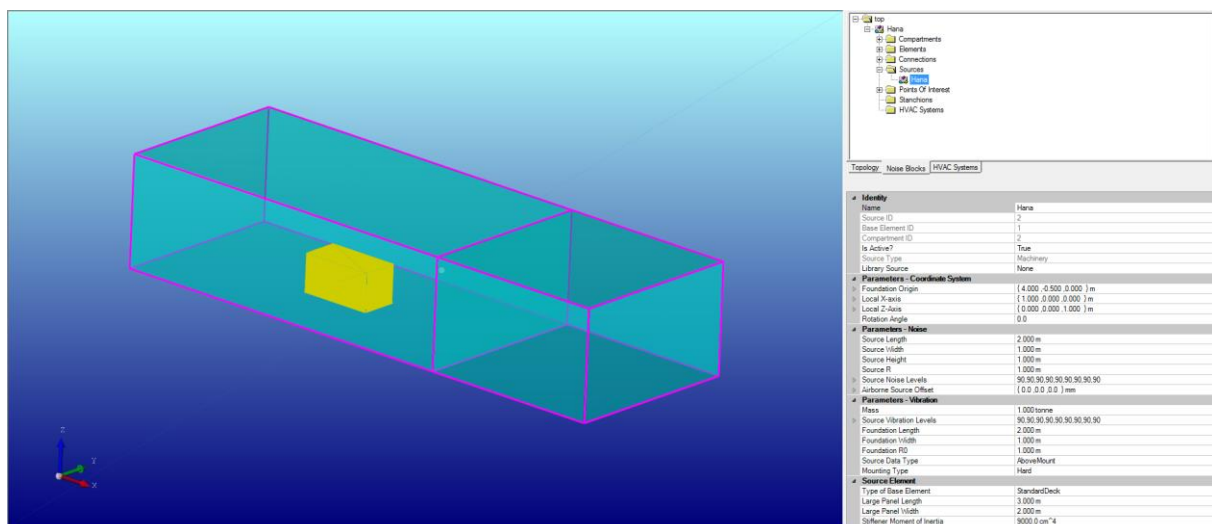

Figure 39 Simple model for noise analysis

In order to inspect how noise propagates through the steel structure in the compartment 2, noise propagation analysis was based on three different noise mitigation concepts. The first analysis has been made with different thickness of steel structure, ranging from 6 mm to 20 mm, with step of 2 mm. The second analysis was based on applying different insulation material types having different thickness. In the third step, the distance between the engine and the observed compartment was varied.

6.3. Results

In Table 21 the noise levels for compartment 2 are presented, as well as calculated noise levels in the point of interest (POI), that is located in the compartment 1, for different steel thickness. It is shown that air-borne noise decreases by 3 dB with thickening of the steel structure by 14 mm, which is the material increase of 70%. With the thickening of the structure, structure-borne noise increases by 11 dB. With thickening of steel by 6 mm to 20 mm, noise attributed to 2nd structure borne path increases by 3 dB, but decreases when steel thickness is 8 mm, 14 mm and 16 mm. With the increase of steel structure noise summation generally increases from 1.4 % to 5.4 %, except for steel thickness of 8 mm, when noise in the observed compartment decreases by 1 dB. In Figure 40 are presented noise analysis results for steel structure thickness of 10 mm, and in Figure 41 are presented noise analysis results for POI located in the compartment 1.

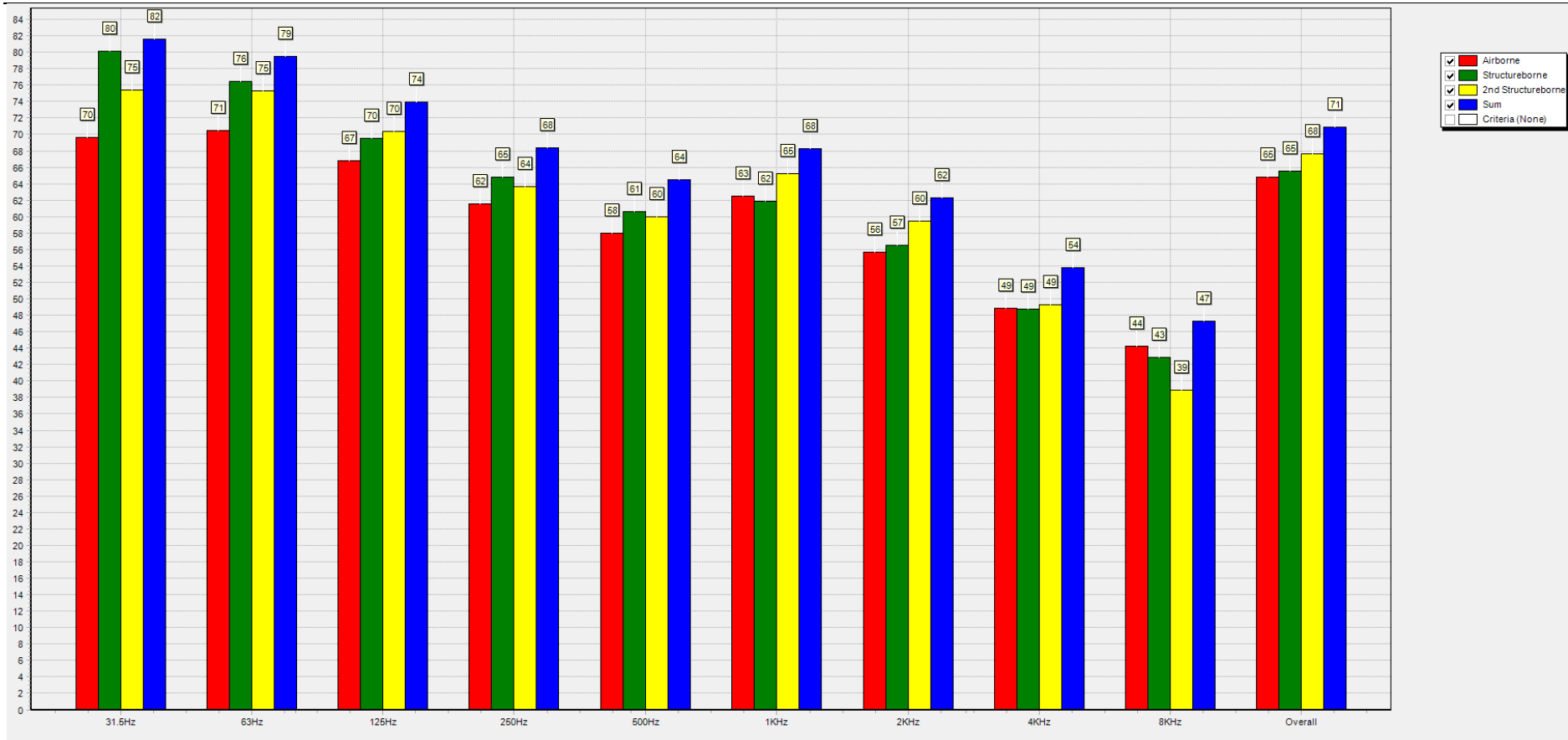

Figure 40 Noise analysis results for steel thickness of 10 mm

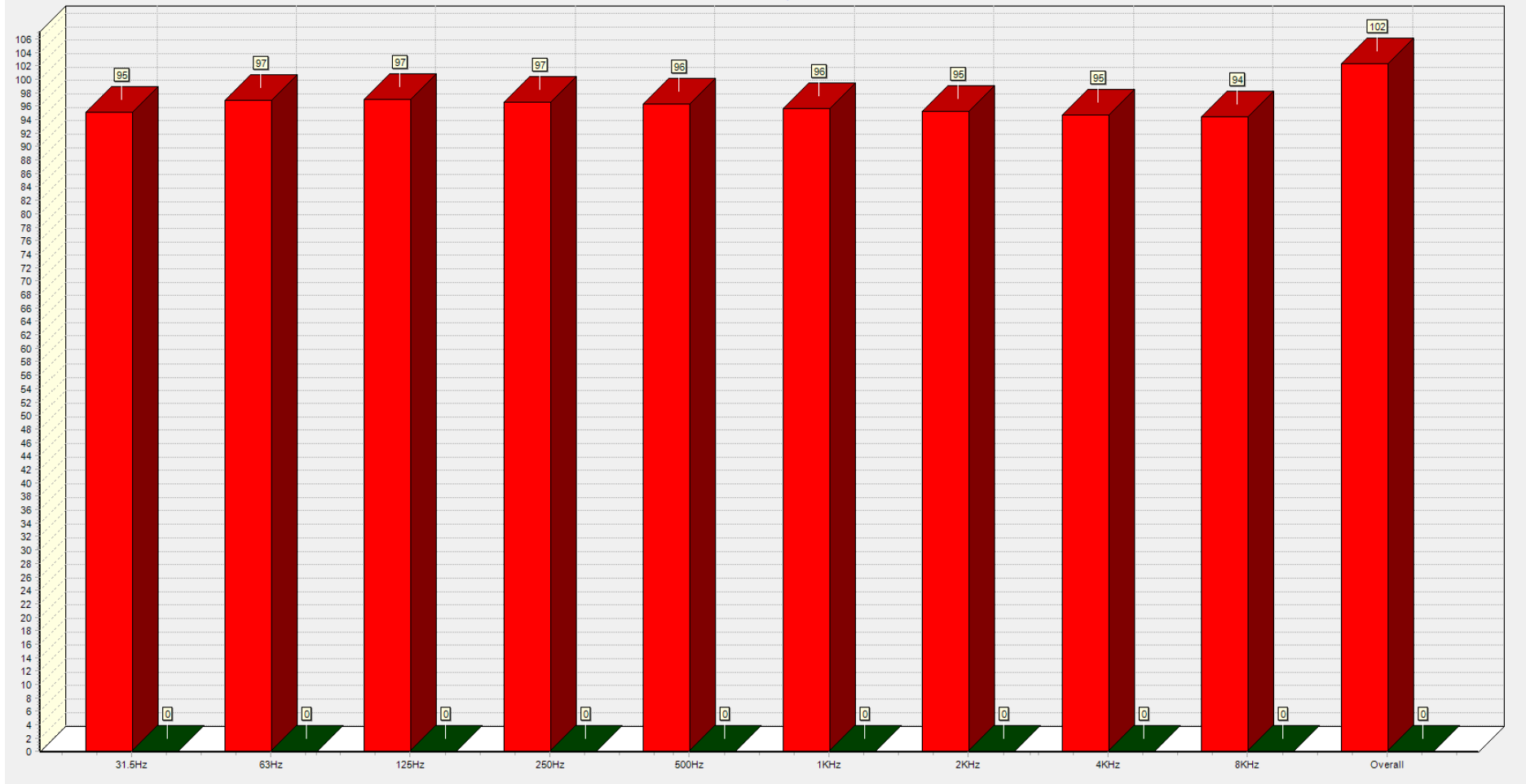

Figure 41 Noise calculated in the point of interest

Table 21 Noise levels in dB(A) analyzed for overall frequencies

Structure thickness	POI	Compartment			
		ABN	1 st SBN	2 nd SBN	SUM
6 mm	102	66	61	67	70
8 mm	102	65	63	66	69
10 mm	102	65	65	68	71
12 mm	102	65	68	69	72
14 mm	102	64	69	68	72
16 mm	102	63	70	68	72
18 mm	102	63	71	69	74
20 mm	102	63	72	70	74

In the analysis performed for different insulation material types and thickness, insulation materials were added on the steel thickness of 10 mm, on the inside of compartment 1. Insulation materials used and their specifications are given in Table 22.

Table 22 Properties of different insulation materials

Material	Material Thickness (mm)	Description	125 Hz	250 Hz	500 Hz	1000 Hz	2000 Hz	4000 Hz	8000 Hz
MIL-I-742 Type I	25	Fiberglass Board w/ non-perforated cloth reinforced Mylar	0.15	0.7	0.98	0.5	0.22	0.08	0.07
MIL-I-742 Type I	50	Fiberglass Board w/ non-perforated cloth reinforced Mylar	0.6	1.1	0.84	0.46	0.25	0.13	0.12
MIL-A-23054	25	Fiberglass w/ waffleboard and perforated fiberglass facing	0.36	0.93	1.18	1.11	0.96	0.87	0.85
MIL-I-2203 Type III	50	Fiberglass w/ non-perforated Tuffskin facing	0.52	1	1	0.88	0.56	0.31	0.25
DOD-I-24688 Type I	25	Non-faced Polyimide foam	0.15	0.27	0.65	1	0.94	0.9	0.95
DOD-I-24688 Type I	50	Non-faced Polyimide foam	0.28	0.55	1	0.98	0.88	0.93	0.96
DOD-I-24688 Type II	25	Polyimide foam w/ perforated fiberglass cloth facing	0.09	0.31	0.87	0.87	0.95	0.96	0.97
DOD-I-24688 Type II	50	Polyimide foam w/ perforated fiberglass cloth facing	0.27	0.81	1	0.97	1	0.98	0.99

Table 23 Noise levels in dB(A) for insulation materials and thickness

	Thickness	ABN	1ST SBN	2ND SBN	SUM
MIL-I-742 Type I	25 mm	59	65	65	69
	50 mm	55	65	65	68
MIL-A-23054	25 mm	58	65	65	68
MIL-I-2203 Type III	50 mm	55	65	64	68
DOD-I-24688 Type I	25 mm	60	65	65	69
	50 mm	58	65	65	68
DOD-I-24688 Type II	25 mm	60	65	65	69
	50 mm	58	65	65	68

The results given in Table 23 unambiguously show that insulation materials of any kind are useful for noise attenuation only up to some degree, which in this case is up to 3 dB. By doubling insulation thickness noise in the observed compartment 2 usually decrease by only 1 dB more than with the insulation of 25 mm.

As the distance between the engine and the compartment 2 changed by only 6.5 m, Figure 42 and Figure 43, noise levels in the observed compartment 2 changed as shown in Table 24.

Case when the engine is closest to the observed compartment will be referred as the case A, and accordingly, case when the engine is most distant to the observed compartment will be referred as case B.

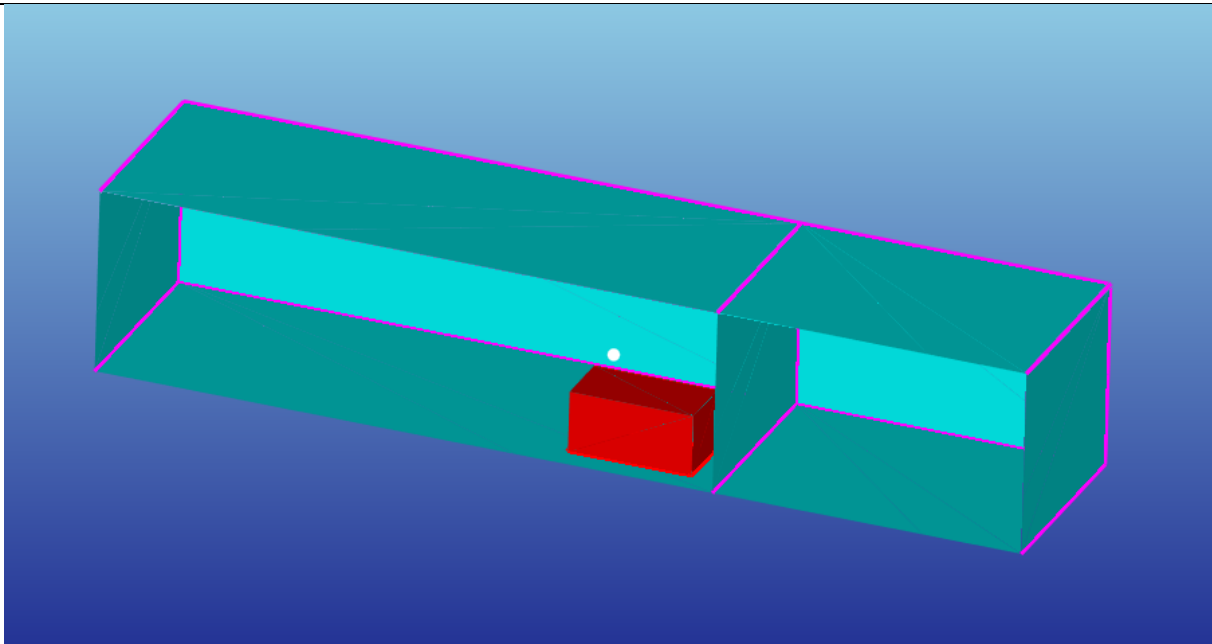

Figure 42 Case of the closest engine to the compartment

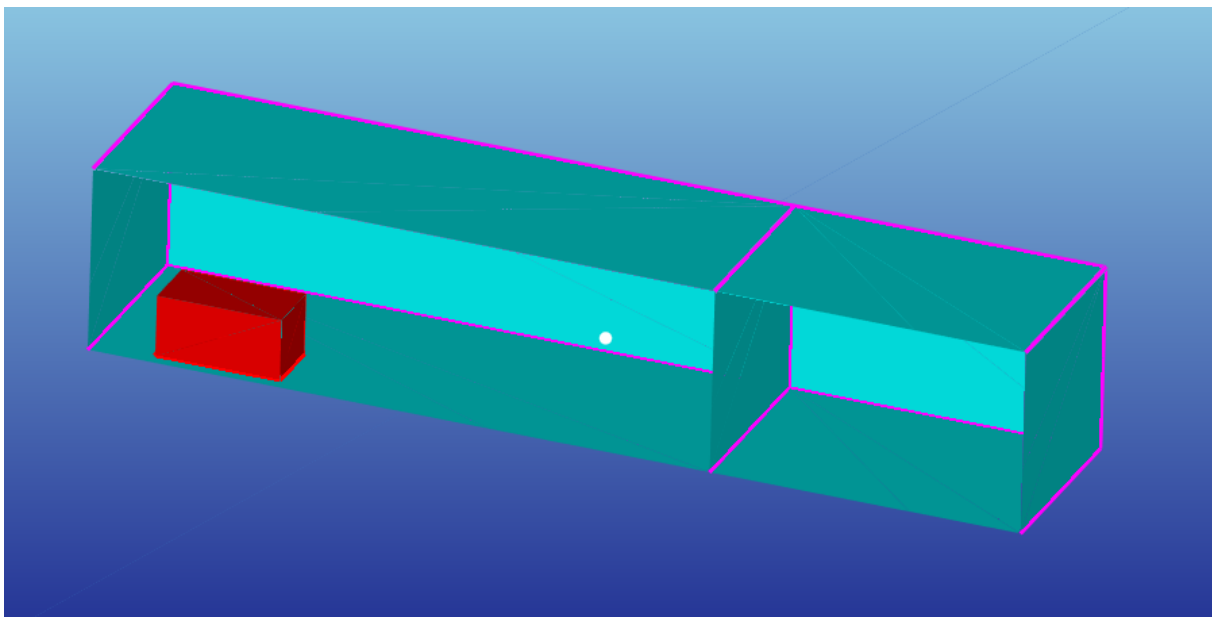

Figure 43 Case of the most distant engine to the compartment

Table 24 Noise levels in the observed compartment according to the engine position

	ABN	1 ST SBN	2 ND SBN	SUM
Case A	66	68	68	72
Case B	65	64	67	70

By moving the engine by 6.5 m away from the observed compartment, the noise in that compartment decreased by 2 dB(A). This leads to the conclusion that increasing distance between the source and the receiver is moderately efficient noise mitigation method, but unfortunately, on board ship is not possible to dislocate engine from the spaces where people habitat.

Furthermore, attenuation of noise with insulation materials shows to be effective for thinner insulations, but with the increase of the thickness noise in the observed compartment decreases by only 1 dB. It is evident that this mitigation technique is very expensive, but not as effective after reaching some value.

Lastly, by changing thickness of steel structure is counterproductive, because noise actually increases by up to 4 dB with the increase of steel in the compartments. Reason behind this non intuitive response is that, according to Table 21, ABN decreases less than SBN increases.

7. CONCLUSION

7.1. Concluding remarks of the thesis

This thesis was focused on noise and vibration on board passenger cruise ships and in the presented work the following subjects were thoroughly investigated and described: the importance of Classification Societies in marine industry with particular emphasis to comfort issues, basic noise and vibration propagation modes, correlation analysis between measured engine response and prescribed vibration velocity limit values, impact of vibration response on the passenger cabin prices and analysis of noise influencing parameters.

Although in most countries Classification is not legal requirement, a ship without class can neither be insured nor mortgaged, and therefore all ships are sailing under some Classification Society institution [18]. Classification Societies play important role in improving habitability of passengers and crew on board. Although the Rules prescribed by Classification Societies are important in preserving comfort on board, unfortunately Rules cannot guarantee perfect conditions for everybody. Comfort is very complex issue since it is a product of both subjective and objective component, and in order to satisfy suitable level of comfort it would be ideal to consider both Rules and experience of the shipbuilders and ship-owners for developing technologies that would result with lower response in critical spaces [19].

Passenger cruise ships are very complex systems and their structure significantly affects noise and vibration transmission and propagation throughout the ship, and consequently the response at observed location. In order to get best possible comfort in passenger spaces both excitation source and transmission path must be included in investigation and results would be most satisfactory if mitigation technologies would be applied upon both of them. Surprisingly, engine's vibration excitations have negligible little influence on vibration response at passenger cabin, because passenger cabins are positioned on higher decks, while on the lower decks engine vibrations disturb and annoy passengers and crew, for example in the restaurants and bars. For the considered cases, the propeller has dominant vibration contribution on board, and therefore has more influence on vibration in passenger cabins.

Regarding noise response on board it is worthy to mention that absorption of insulation materials is not linear to the thickness of the insulation material. This means that after certain limit insulation materials become unduly expensive and ineffective. As previously indicated

in chapter 6, it is counterproductive to increase thickness of steel structure, because in the adjacent compartment noise levels increase up to 4 dB(A), and moreover structural weight significantly increases. Lastly, the energy density of sound waves decreases as they spread out, so that increasing the distance between the receiver and source results in lower sound intensity at the receiver [20]. But unfortunately dislocating noise source from the receiver on a ship in most cases is impossible. Therefore in order to mitigate and cancel noise levels at the receivers, certain mitigation technologies should be applied on the engine.

7.2. Recommendations for further research

Recommendations for future work are as follows:

1. It is highly recommended to make analysis based on noise distribution and cabin prices on board passenger ship in order to assess how much noise coming from the engine contaminates spaces where passengers are present.
2. Also, it is highly recommended to investigate problems that passenger cruise ships have when sailing long distance routes in rather short period. When passenger ships have to reach long distance destinations in short period their engines must run above nominal speed and nominal load. This mode of operation can lead to excessive vibration, which can be interesting and challenging area for noise and vibration reduction.
3. In the near future new classification notation, named Silent Class [22], will be introduced in order to protect and preserve marine life. Namely, sea mammals developed sharp hearing capabilities in order to compensate their poor visibility [23], and sea mammals get severely affected with excessive noise coming from ships. Nowadays only survey vessels, ocean research ships and fishing vessels are classified with Silent Class, but it is reasonable to expect that in the future all ships will have to satisfy Silent Class, due to above mentioned reasons. Therefore in the near future engine manufacturers, propulsion manufacturers and shipbuilders will have to offer more advanced solutions for mitigation or at least reduction of excessive noise and vibrations. Nowadays, Silent Class is still not mandatory requirement that Classification Societies push upon shipbuilders and ship owners, but in the near future it will be mandatory. Also, it is our moral obligation to protect diversity of marine life.
4. Although river cruise ships are not as common and frequent as sea and ocean cruise ships are, Cruise Line International Association, Inc. states that in 2017 ordering new

river cruise ships had an increase of 17 %. The river cruises are rather small ships compared to the ocean cruise ships, and therefore nearness of the engine to the passenger spaces is inevitable, which can lead to decreased discomfort on board. Also, because of the depth of the river and the shape of the river basin reflection and refraction of the noise that propeller and engine emit into the water can occur. This excessive pressure could again disturb the ship and create structure borne noise on the ship's hull. Finally, river ships sometimes must sail against the current, and in order to maintain default rate, engines must drive above their nominal speed and load, which consequently leads to excessive vibrations. This implies that application of four stroke diesel engines for river ships will require additional attention, bearing in mind noise and vibration aspects.

It is possible to mitigate noise and vibration to the point that their response is almost cancelled, as for instance war ships. Mostly the problem with attenuation of noise and vibration is not impossibility of mitigation, but the cost of technologies that would effectively reduce them to the required level. Therefore, the goal should be finding appropriate, effective and economically justified technologies that would mitigate or almost cancel noise and vibration excitations.

REFERENCES

- [1] Pestelli, C., Almerigogna M., Tienhaara H.: Machinery noise and vibration sources 2017.
- [2] The Maritime Safety Committee: Adoption of the Code on Noise Levels on Board Ships, Annex 1, 30 November 2012.
- [3] Parker P.: Sybil, Acoustics source book, 1988.
- [4] Bruel & Kjør: Acoustic Noise Measurements, 1979.
- [5] DNV-GL: Comfort Class, 2011.
- [6] Thomson T.,W.: Theory of Vibration with Applications, CRC Press, 01.02.1996.
- [7] Lloyd's Register of Shipping: Passenger and Crew Accommodation comfort, 2016.
- [8] Lloyd's Register: Ship Vibration and Noise – Guidance Notes, July 2006.
- [9] Lewis M., F, Membert C.: Propeller Vibration,
<http://www.sname.org/HigherLogic/System/DownloadDocumentFile.ashx?DocumentFileKey=c57ff759-dc93-4892-b8d4-84a8f35094db>
- [10] Hound, N.: <https://www.iims.org.uk/introduction-propeller-cavitation/>, 14.01.2015.
- [11] International Association of Classification Societies:
<http://www.iacs.org.uk/media/3785/iacs-class-what-why-how.pdf>, January 2015.
- [12] Bureau Veritas: Comfort on Board, July 2016.
- [13] Vibes Corp: <http://www.vibescorp.ca/learn-about/basic-understanding-of-machinery-vibration/>, 08.02.2017.
- [14] Rockwool: <http://www.rockwool-searox.com/applications+-c12+-constructions/>
- [15] Wikipedia: https://en.wikipedia.org/wiki/MSC_Musica , last edited 06.06.2017.
- [16] Cruise Critic: <https://www.cruisedeckplans.com/DP/deckplans/MSC-Poesia>
- [17] Designer-NOISE: <http://www.noise-control.com/designernoise.php>
- [18] Hellenic Shipping News: <http://www.hellenicshippingnews.com/shipping-the-role-of-classification-societies/>
- [19] De Lorenzo, F.: Noise & vibration control on board luxury passenger ships
- [20] Wikipedia: <https://en.wikipedia.org/wiki/Soundproofing>
- [21] Eisenberg, P.: <http://web.mit.edu/hml/ncfmf/16CAV.pdf>
- [22] DNV-GL: Silent Class Notation, January 2010.

[23] Isolation Tech: <http://blog.isolationtech.com/the-effects-of-noise-and-vibration-on-marine-life/>

APPENDIX

I. CD-R disc