

Konstruiranje nastavne makete za upravljanje i regulaciju istosmjernim motorima

Bukal, Stjepan

Undergraduate thesis / Završni rad

2010

Degree Grantor / Ustanova koja je dodijelila akademski / stručni stupanj: **University of Zagreb, Faculty of Mechanical Engineering and Naval Architecture / Sveučilište u Zagrebu, Fakultet strojarstva i brodogradnje**

Permanent link / Trajna poveznica: <https://urn.nsk.hr/urn:nbn:hr:235:938086>

Rights / Prava: [In copyright](#)/[Zaštićeno autorskim pravom.](#)

Download date / Datum preuzimanja: **2025-01-28**

Repository / Repozitorij:

[Repository of Faculty of Mechanical Engineering and Naval Architecture University of Zagreb](#)





Sveučilište u Zagrebu
Fakultet strojarstva i brodogradnje



ZAVRŠNI RAD

KONSTRUIRANJE NASTAVNE MAKETE ZA UPRAVLJANJE I REGULACIJU ISTOSMJERNIM MOTORIMA

Voditelj rada:

Prof.dr.sc. Mladen Crneković

Stjepan Bukal

4-MEHROB

0035156196

Zagreb, 2010

Izjava

Izjavljujem da sam završni rad izradio samostalno uz stručnu pomoć prof. dr. sc. Mladena Crnekovića, kojem se posebno zahvaljujem.

Posebno se zahvaljujem dr. sc. Danijelu Pavkoviću na bezgraničnom strpljenju te ukazanom povjerenju.

Stjepan Bukal



SVEUČILIŠTE U ZAGREBU
FAKULTET STROJARSTVA I BRODOGRADNJE
Središnje povjerenstvo za završne i diplomske ispite
Povjerenstvo za završne ispite studija strojarstva za smjerove:



proizvodno inženjerstvo, računalno inženjerstvo, industrijsko inženjerstvo i menadžment, inženjerstvo materijala i mehatronika i robotika

Sveučilište u Zagrebu	
Fakultet strojarstva i brodogradnje	
Datum	Prilog
Klasa:	
Ur.broj:	

ZAVRŠNI ZADATAK

Student: **STJEPAN BUKAL**

Mat. br.: 0035156196

Naslov: **KONSTRUIRANJE NASTAVNE MAKETE ZA UPRAVLJANJE I
REGULACIJU ISTOSMJERNIM MOTORIMA**

Opis zadatka:

U radu pristupnik mora uraditi sljedeće:

1. Osmisliti strukturu nastavne makete s malim istosmjernim motorima opremljenim inkrementalnim davačima impulsa. Pritom treba predvidjeti prostor za jednofazni transformator i sklop ispravljača za napajanje, sklop pojačala snage motora, te razne konektore (priključak napona napajanja i signalnih linija). Proučiti kataloge proizvođača relevantnih komponenti, sastavnih dijelova i opreme, te odabrati one koji najbolje odgovaraju zadanoj primjeni.
2. U suradnji s osobljem Katedre za strojarску automatiku izraditi projektu dokumentaciju (radioničke i montažne crteže) u nekom od prikladnih programskih paketa za projektiranje mehaničkih sustava (AutoCAD, SolidWorks, CATIA, ProEngineer i sl.), a koji će poslužiti za izradu nastavnih maketa.
3. Provjeriti funkcionalnost makete u nekom od gore navedenih programskih paketa za projektiranje mehaničkih sustava.

Zadatak zadan:
11. prosinca 2009.

Rok predaje rada:
Prosinac 2010.

Zadatak zadao:

Predsjednik Povjerenstva:

Prof. dr. sc. Mladen Crneković

Prof. dr. sc. Dubravko Majetić

SADRŽAJ

I	Izjava.....	2
II	Zadatak.....	3
III	Sadržaj.....	4
IV	Popis slika i tablica	5
1.	UVOD	8
2.	MIKROKONTROLERSKI SUSTAV ZASNOVAN NA PROGRAMIBILNOM LOGIČKOM KONTROLERU SIMATIC S7- 200.....	9
2.1	SIMATIC S7-224 CPU	9
2.2	EKSTENZIJSKI MODULI ZA SIEMENS S7-224	11
2.2.1	Modul napajanja LOGO! POWER	12
2.2.2	Ekstenzijski modul EM 223	13
2.2.3	Ekstenzijski modul EM 231	14
2.2.4	Ekstenzijski modul EM 232	15
2.3.	Laboratorijska maketa mikroprocesorskog sustava	16
3.	MAKETA ZA UPRAVLJANJE I REGULACIJU ISTOSMJERNIH MOTORA.....	17
3.1	Struktura makete	17
3.2	Sklop nastavne makete	18
3.2.1	Glavna ploča.....	19
3.2.2	Oplošje	19
3.1.3	Bočna ploča A.....	20
3.1.4	Bočna ploča B.....	21
3.1.6	Ventilator	22
3.1.7	DC Motori.....	22

3.1.7.1 Inkrementalni davač	24
3.1.8 Nosač motora.....	24
3.1.9 Spojka.....	25
3.1.10 Spojni elementi	26
3.1.11 Napajanje makete	27
3.1.12 Regulacijska elektronika.....	28
Zaključak.....	30
Literatura.....	31
Radionički crteži.....	32
Popis priloga	42

Popis slika i tablica

TABLICA 2.1 SPECIFIKACIJE MODULA NAPAJANJA LOGO!POWER	12
TABLICA 2.3 SPECIFIKACIJE DIGITALNIH IZLAZA ZA EM 223	13
TABLICA 2.4 PODACI ANALOGNIH ULAZA EM 231	14
TABLICA 2.5 PODACI ANALOGNIH IZLAZA EM 232	15
TABLICA 3.1 POZICIJE ELEMENATA MAKETE.....	18
TABLICA 3.2 IZVOD IZ TVORNIČKIH PODATKA ZA PITTMAN 9232	23
TABLICA 3.3	24
TABLICA 3.3 TEHNIČKI PODACI SPOJKE.....	25
TABLICA 3.4 DIN 7981 VIJAK ZA LIM	26
TABLICA 3.5 TEHNIČKE KARAKTERISTIKE NAPAJANJA TRACO POWER TXL 150-24S.....	27
SLIKA 2.1 S7-200 PLC MODEL CPU 224	9
SLIKA 2.2 PUNI PROGRAMSKI CIKLUS	10
SLIKA 2.3 SHEMATSKI PRIKAZ KOMPONENTI MAKETE	11
SLIKA 2.4 LOGO!POWER MODUL NAPAJANJA.....	12
SLIKA 2.5 EKSTENZIJSKI MODUL EM 223	13
TABLICA 2.2 SPECIFIKACIJE DIGITALNIH ULAZA ZA EM 223.....	13
SLIKA 2.6 EKSTENZIJSKI MODUL EM 231	14
SLIKA 2.7 EKSTENZIJSKI MODUL EM 232	15
SLIKA 2.8 MAKETA SA LCD POKAZNIKM	16
SLIKA 3.1 STRUKTURA MAKETE.....	17
SLIKA 3.2 MODEL MAKETE ZA UPRAVLJANJE I REGULACIJU ISTOSMJERNIH MOTORA	18
SLIKA 3.3 GLAVNA PLOČA	19
SLIKA 3.4 OPLOŠJE.....	19
SLIKA 3.5 BOČNA PLOČA A	20
SLIKA 3.6. BOČNA PLOČA B	21
SLIKA 3.7 VENTILATOR	22
SLIKA 3.8 PITTMAN 9232 SA INKREMENTALNIM DAVAČEM E30B	22
SLIKA 3.9 NOSAČ MOTORA	24

SLIKA 3.10 SPOJKA	25
SLIKA 3.11 L-PROFIL (HRN DIN 59413 20X20X1.5).....	26
SLIKA 3.12.....	27
SLIKA 3.13.....	28
SLIKA 3.14 INTEGRIRANI KRUG TIPRA LM 18200	29
SLIKA 3.15 ULAZNO IZLAZNA KARAKTERISTIKA LM18200T	29
SLIKA 3.16 SHEMA SKLOPA INKREMENTALNOG DAVAČA	30

1. UVOD

Ovaj rad bavi se projektiranjem i razvojem nastavne makete za upravljanje i regulaciju istosmjernim motorima, u svrhu modernizacije Laboratorija za elektrotehniku. Time bi se poboljšala kvaliteta nastave iz kolegija iz područja elektrotehnike, mikroprocesorskog upravljanja i regulacije.

Za potrebe projektiranja makete predviđeno je korištenje CATIA V5 programskog paketa (proizvođač „Dassault Systemes“). Navedeni programski paket predviđen je i za provjeru funkcionalnosti i sklapanja pojedinih podsustava makete. Pri izradi makete također se vodi računa o kompatibilnosti s postojećim nastavnim maketama, kao što je maketa mikrokontrolerskog sustava sa Siemens SIMATIC S7-200 programibilnim logičkim kontrolerom. Što se detaljno opisuje u ovom radu.

Na kraju, dane su specifikacije svih komponenti, sklopovlja i uređaja koji su predviđeni za ugradnju na danu nastavnu maketu.

2. MIKROKONTROLERSKI SUSTAV ZASNOVAN NA PROGRAMIBILNOM LOGIČKOM KONTROLERU SIMATIC S7- 200

2.1 SIMATIC S7-224 CPU

Programibilni logički kontroleri služe za upravljanje industrijskim procesima, a najčešće se upotrebljavaju u proizvodnji, za automatizaciju postrojenja i procesa. Osnovne karakteristike PLC-a su visoka pouzdanost, prilagodljivost, mogućnost povezivanja i komunikacije sa drugim uređajima (upravljačke jedinice za motore), fleksibilnost upravljanja procesom, (jednostavnost izmjene upravljačkog programa).

S7-200 CPU u jedinstvenom kućištu sadrži mikrokontroler, sklopove za serijsku komunikaciju, priključke za vanjsko napajanje 24 V DC (ili 230 V AC), te digitalne ulaze i izlaze u tranzistorskoj (optički odvojenoj) izvedbi (24 V DC napajanje), odnosno relejnoj izvedbi (230 V AC napajanje). U ovom radu razmatra se PLC S7-224 čiji su ugrađeni (on-board) digitalni ulazi i izlazi izvedeni u tranzistorskoj tehnici (vidi detaljnije [1]).

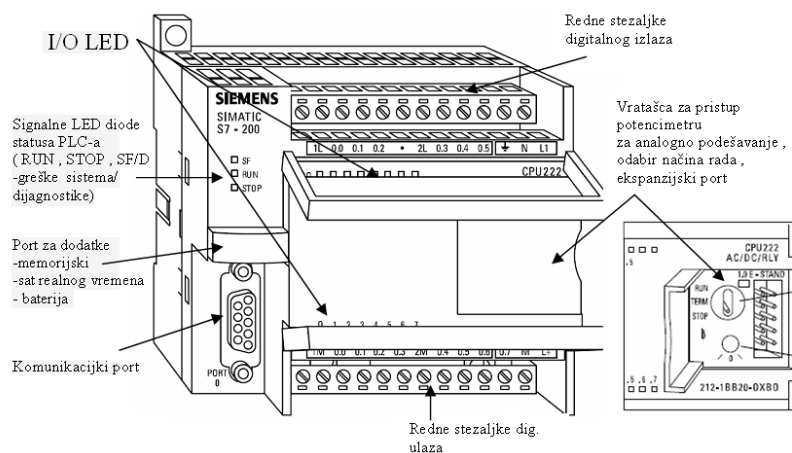

Slika 2.1 S7-200 PLC model CPU 224

Sam PLC ima 14 digitalnih ulaza, te 10 digitalnih izlaza. CPU jedinica prikazan na slici 2.1. sadrži port za komunikaciju (programiranje), signalne LED diode statusa PLC-a (SF/D – greška sistema / dijagnostike; RUN – početak rada; STOP – završetak rada). Na CPU modulu se

nalazi memorija (32 kB programske memorije, 64 kB odnosno 256 kB podatkovne memorije), sat realnog vremena, baterija za čuvanje podataka (do 200 sati), sklopka za odabir rada (RUN/ TERM/ STOP) i ekspanzijski port.

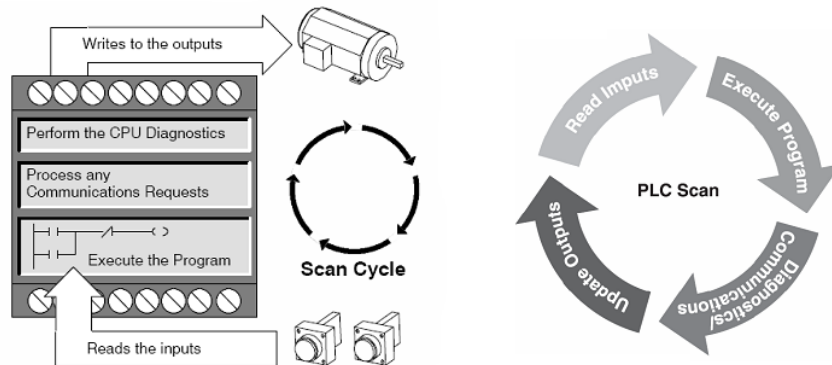

Slika 2.2 Puni programski ciklus

PLC ciklički izvršava slijed (sekvencu) instrukcija programa kako je prikazano na slici 2.2. Jedan puni programski ciklus (naziva se još i „SCAN CYCLE“) sastoji se od sljedećih segmenata[1]:

Čitanje stanja ulaza - fizička stanja ulaza se kopiraju u registar slike stanja ulaza. Poseban dio memorije radi lakšeg dohvata i konzistentnosti logičkih stanja i analognih mjernih veličina (stanja na fizičkim ulazima se mogu mijenjati u većoj ili manjoj mjeri zbog utjecaja smetnji...).

Izvršavanje slijeda instrukcija (unutar programa) - izvršavanje slijeda instrukcija programa i spremanje podataka na odgovarajuće memorijske lokacije (bit memorija, memorija za varijable, ...).

Procesiranje zahtjeva za komunikaciju s ostalim uređajima i eventualna uspostava komunikacije ako je to potrebno.

Dijagnostička provjera – provjera EPROM-a (firmware-a), memorije i svih ekstenzijskih modula.

Ispis podataka na izlaze – vrijednosti koje su bile u drugom koraku pohranjene u registar slike stanja izlaza prosljeđuju se na fizičke izlaze PLC-a S7-200.

2.2 EKSTENZIJSKI MODULI ZA SIEMENS S7-224

Prednost PLC-a je njegova modulularnost, zbog proširenja ulaza i izlaza dodaje se ekstenzijski moduli. Ti moduli se spajaju na PLC putem serijske veze tipa RS-485.

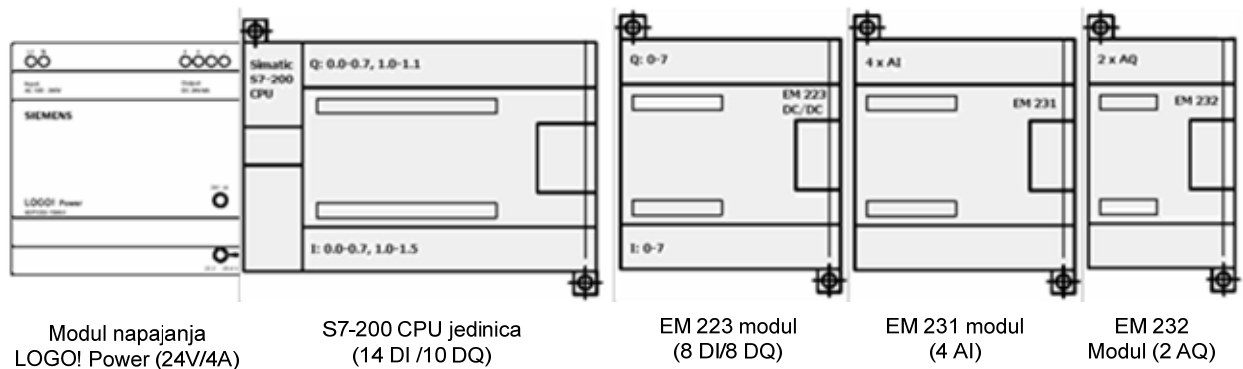

Slika 2.3 Shematski prikaz komponenti makete

Maketa koju koristimo u radu sastoji se od 4 ekstenzijska modula od kojeg je jedan napajanje sustava. Na slici 2.3 prikazan je raspored modula.

2.2.1 Modul napajanja LOGO! POWER



Slika 2.4 LOGO!Power modul napajanja

LOGO!Power napajanja je za napajanje LOGO! modula (najjednostavnija porodica Siemensovih PLC-a), ali ih je moguće primjeniti i za napajanje drugih trošila (te su u ovom radu odabrani kao izvori napajanja CPU jedinica i ekstenzijskih modula PLC makete). Ističe ga mala osjetljivost na promjenu ulaznog napona (raspon od 85 do 264 V). Modul signalizira ispravan rad pomoću LED diode. Specifikacije modula napajanja navedene su u tablici 2.1. Modul je prikazan na slici 2.4[1].

Tablica 2.1 Specifikacije modula napajanja LOGO!Power

Parametri modula napajanja LOGO!Power [2]	
Veličina	Vrijednosti
ulazni jedno fazni napon	85 do 264 V
izlazni napon (DC)	24 V \pm 3%
izlazna struja	do 4 A
faktor korisnosti	89%
zaštita od kratkog spoja	DA
struja kratkog spoja (DC)	10 A

2.2.2 Ekstenzijski modul EM 223



Slika 2.5 Ekstenzijski modul EM 223

Ekstenzijski modul prikazan na slici 2.5 sadrži 8 digitalnih ulaza te 8 digitalnih izlaza, namijenjen za proširenje PLC-a serije S7 200. Detaljniji opis može se naći u tablici 2.2 te u tablici 2.3[1].

Tablica 2.2 Specifikacije digitalnih ulaza za EM 223

Parametri digitalnih izlaznih port-ova	
Veličina	Vrijednosti ulaza za EM 223
Tip	Sink/Source (IEC Type 1 Sink)
Nazivni napon	24 V DC pri 4mA
Maksimalno dozvoljeni kontinuirani napon	30 V DC
Probodni napon (max.)	35 V na 0.5 s
Logička 1(min.)	15 .V pri 2.5 mA
Logička 0 (max.)	5 V pri 1 mA

Tablica 2.3 Specifikacije digitalnih izlaza za EM 223

Parametri digitalnih izlaznih port-ova	
Veličina	Vrijednosti izlaza za EM 223
Tip	Solid State-MOSFET (Sourcing)
Nazivni napon	24 V
Raspon napona	od 20.4 V do 28.4 V
Logička 1(min.)	20 VDC pri maksimalnoj struji
Logička 0 (max.)	0.1 V pri 10 kOhm opterećenju
Nazivna struja po točki (max.)	0.75 A

2.2.3 Ekstenzijski modul EM 231



Slika 2.6 Ekstenzijski modul EM 231

EM 231 je ekstenzijski modul S7-200 PLC-a, koji omogućava spajanje dodatna 4 analogna ulaza. Modul se napaja iz izvora napona +24 V.

Analogni ulazni modul pretvara analogne signale dovedene sa senzora u odgovarajuće digitalne varijable (duljine 16 bita), koji služe za daljnu obradu u CPU jedinici.

Modul se može konfigurirati za prijem strujnih ili naponskih analognih signala (ovisno o načinu spajanja) [1]

Tablica 2.4 Podaci analognih ulaza EM 231

Parametri analognih ulaznih port-ova	
Veličina	Vrijednosti ulaza za EM 231
DC ulazna impedancija	$\geq 10 \text{ M}\Omega$ za naponski ulaz 250Ω za strujni ulaz
Maksimalni ulazni napon	30 V DC
Maksimalna ulazna struja	32 mA

2.2.4 Ekstenzijski modul EM 232



Slika 2.7 Ekstenzijski modul EM 232

Analogni izlazni modul slika 2.7 pretvara digitalni podatak CPU jedinice u analognu veličinu koja služi za upravljanje izvršnim elementima (aktuatorima) s analognim naponskim ili strujnim ulazom (npr. Proporcionalni ventil, energetski pretvornici za upravljanje motorima i slično). Analogni izlazni modul sadrži 12 – bitni D/A pretvornik i može se konfigurirati za strujni odnosno naponski izlaz kako je prikazano u tablici 2.6 i u[1]. u ovom radu koristit će se isključivo naponski izlazi.

Tablica 2.5 Podaci analognih izlaza EM 232

Parametri analognih izlaznih port-ova	
Veličina	Vrijednosti izlaza za EM 232
Naponski izlaz	$\pm 10 \text{ V}$
Strujni izlaz	0 – 20 mA

2.3. Laboratorijska maketa mikroprocesorskog sustava



Slika 2.8 Maketa sa LCD pokaznikom

Na slici 2.8 prikazana je maketa Siemens S7-200 sa LCD pokaznikom. Maketa je ožičena sa DB konektorima. Zaštita PLC-a i ekstenzijskih modula riješena je optokaplerski tako da ne može doći do trajnog oštećenja PIC-a već da stradaju relativno jeftiniji optokapleri.

3.MAKETA ZA UPRAVLJANJE I REGULACIJU ISTOSMJERNIH MOTORA

3.1 Struktura makete

Maketa je osmišljena kao simulator za upravljanje i regulaciju istosmjernih motora (slika3.1). Predviđeno je da maketa ima mogućnost emuliranja realnih regulacijskih zadataka u elektromotornim pogonima, te su stoga dva istosmjerna motora spojena na istu osovinu.. Jedan motor predstavlja objekt regulacije dok drugi predstavlja varijablina teret. Motori su spojeni zajedno preko spojeke stoga je bilo potrebno implementirati samo jedan senzor kuta zakreta vratila(inkrementalni davač).

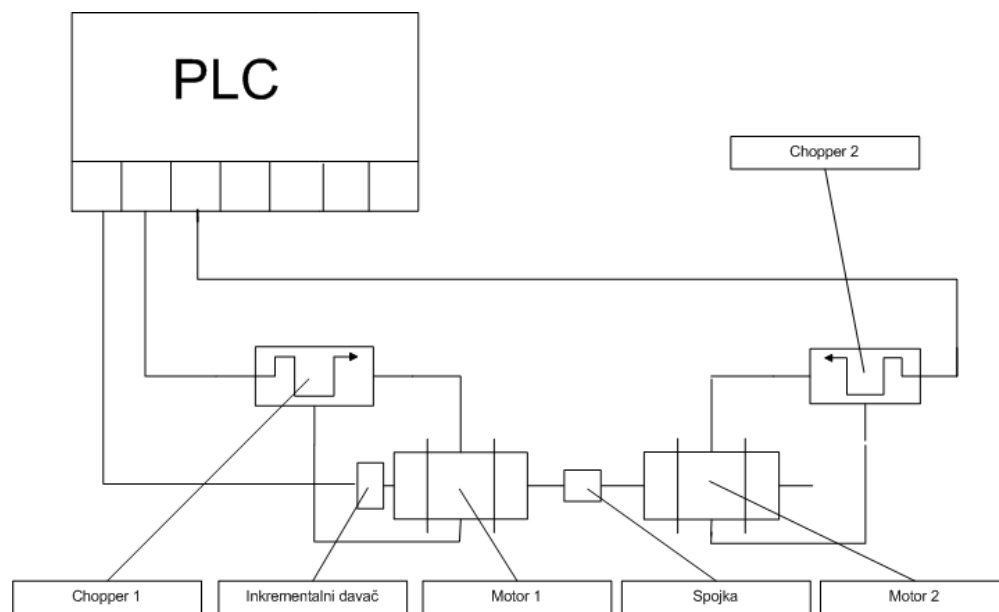

Slika 3.1 Struktura makete

3.2 Sklop nastavne makete

Tablica 3.1 Pozicije elemenata makete

Poz.Br.	NAZIV	Poz.Br.	NAZIV	Red.Br.	NAZIV	Poz.Br.	NAZIV
1	Glavna ploča	6	Ventilator	11	Nosac bocne stranice 1	16	Nosac bocne stranice 6
2	Oplošje	7	Motor 1	12	Nosac bocne stranice 2	17	Nosac bocne stranice 7
3	Bočna ploča A	8	Motor 2	13	Nosac bocne stranice 3	18	Nosac bocne stranice 8
4	Bočna ploča B	9	Nosač motora 1	14	Nosac bocne stranice 4	19	Nosac zadnje stranice
5	Nosač priključaka	10	Nosač motora 2	15	Nosac bocne stranice 5	20	Napajanje
21	Nosač napajanja 1	22	Nosač napajanja 2	23	Spojka		

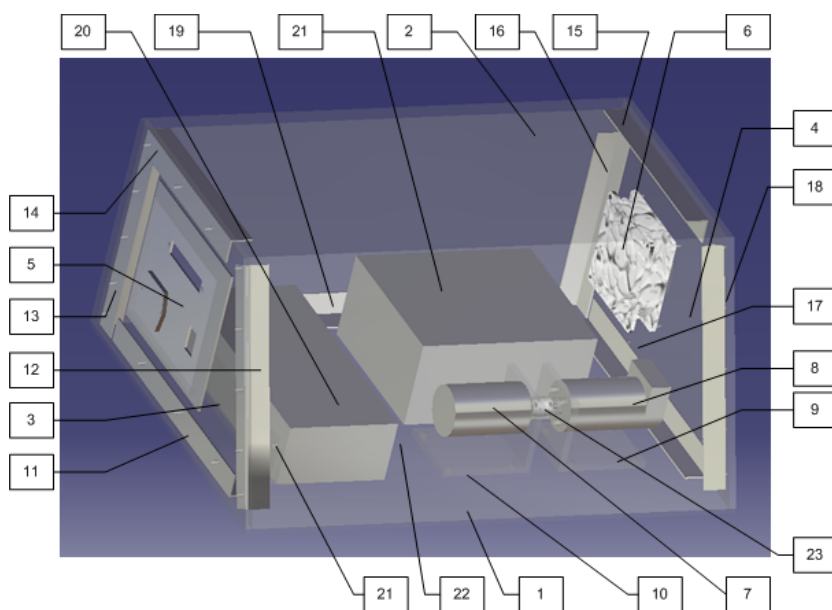

Slika 3.2 Model makete za upravljanje i regulaciju istosmjernih motora

Maketa prikazana na slici 3.1 sastoji se od 23 dijela, čiji su nazivi navedeni u tablici 3.2. Model makete je razvijen uz pomoć Catia programskog paketa[3].

3.2.1 Glavna ploča

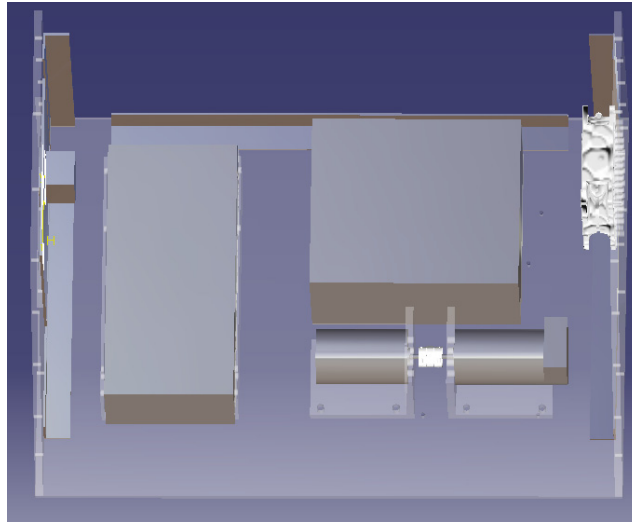

Slika 3.3 Glavna ploča

Glavna ploča prikazana na slici 3.3 je bazni dio makete. Načinjena je od akrilne ploče (komercijalni naziv: "PLEXIGLASS") debljine osam milimetara. Ploča je detaljno opisana u radioničkom crtežu koji se nalazi u prilogu [1].

3.2.2 Oplošje



Slika 3.4 Oplošje

Oplošje prikazano na slici 3.4 načinjeno je od akrila (debljine šest milimetara služi kao zaštita od rotirajućih dijelova. Lice je nakošeno pod kutem od 60° u odnosu na vertikalnu

ravninu tako da je omogućen nesmetan pogled na motore. Radionički crtež se nalazi u prilogu[2].

3.1.3 Bočna ploča A



Slika 3.5 Bočna ploča A

Bočna stranica prikazana na slici 3.5 prikazuje izgled bočne stranice makete. Za material izrade bočne stranice odabran je akril debljine šest milimetara. Bočna stranica fiksira glavnu ploču i oplošje te se na nju fiksira ploča za spojnice. Detaljan opis je radioničkom crtežu [3].

3.1.4 Bočna ploča B

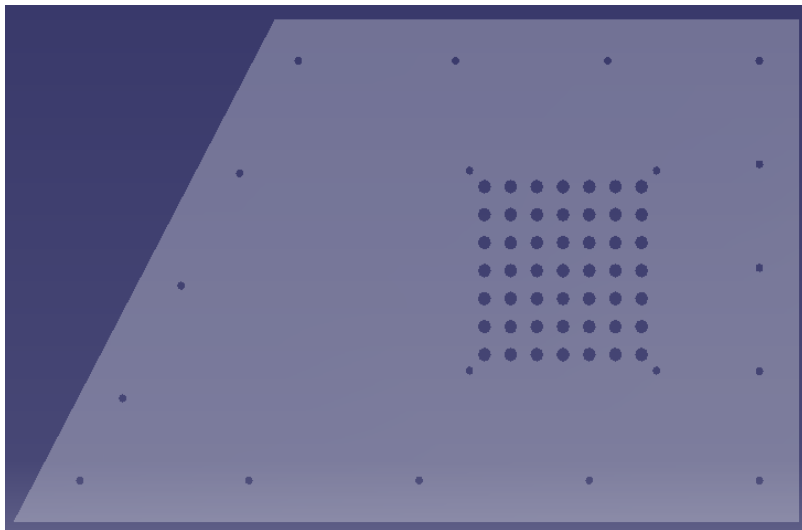

Slika 3.6. Bočna ploča B

Bočna stranica prikazana na slici 3.6 prikazuje izgled bočne stranice makete. Za material izrade bočne stranice odabran je akril debljine šest milimetara. Bočna stranica fiksira glavnu ploču i oplošje te se na nju fiksira ventilator. Radionički crtež nalazi se u prilogu[4].

3.1.6 Ventilator



Slika 3.7 Ventilator

Na slici 3.7 prikazan je ventilator makete. Ventilator se montira na B bočnu ploču. Ventilator se napaja strujom AC 220V/50-60 Hz te troši 100mA, a aktivira se uz pomoć prekidača napajanja makete. Detaljni tehnički podaci nalaze se u prilogu[7].

3.1.7 DC Motori



Slika 3.8 Pittman 9232 sa inkrementalnim davačem E30B

Maketa koristi dva DC motora proizvođača Pittmann [1] model 9232 prikazana na slici 3.8. Motori su imaju kuglične ležajeve te jasno deklarirane tvorničke podatke (Tablica3.2) iz kojih je vidljivo da su dani motori predviđeni za niski napon, te su razmjerno male snage i

okretnog momenta, što je pogodno sa stanovišta ugradnje u nastavnu maketu namijenjenu radu sa studentima.

Tablica 3.2 Izvod iz tvorničkih podatka za Pittman 9232

Naziv	Oznaka	Iznos
Napon napajanja	Vs	24 V
Nominalan moment	Tc	0.017 Nm
Brzina vrtnje kod nominalnog momenta	Sc	5570 rpm
Struja kod nom. momenta	Ic	1.76 A
Nominalna snaga	Pnom	10 W
Konstanta motora	Km	0.011 Nm/W
Konstanta momenta	Kt	0.0311Nm/A
Konstanta napona	Ke	0.0311Vs/rad
Radni otpor armature	Rmt	7.38 Ω
Induktivitet	L	4.64 mH
Stuja praznog hoda	Inl	0.16 A
Brzina praznog hoda	Nnl	6870 rpm
Struja kratkog spoja	Iks	3.25 A
Maksimalni moment	Tpk	0.0961 Nm
Moment trenja	Tf	0.0035 Nm
Faktor prigušenja	D	1,8E-6Nms/rad
Maksimalna temperature zavojnice	Θ_{max}	155°C
Inercija rotora	Jr	1.9E-6 Kgm ²
Masa motora	M	0.198 kg

Vratila motora su spojena zajedno preko spojke tako da su im brzine iste, stoga nema potrebe mjeriti brzinu na oba motora već samo na jednom.

3.1.7.1 Inkrementalni davač

Za mjerenje brzine motora odabran je inkrementalni davač sa dva kanala te indeks kanalom sa rezolucijom od 360 imp/rev. Inkrementalni davač također proizvodi firma Pittman, tako da su motor i davač kompatibilni. U tablici 3.3 su navedeni osnovni tehnički podaci izvedeni iz priloga[2].

Tablica 3.3

Rezolucija	360
Napon napajanja	4.5-5.5 V
Izlazni napon "1"	min 2.4V
Izlazni napon "0"	max 0.4 V
Potrošnja struje	max 80mA

3.1.8 Nosač motora

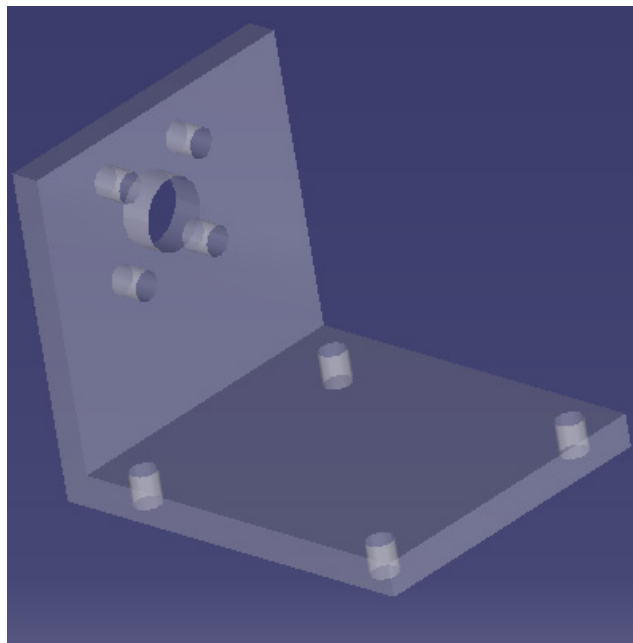

Slika 3.9 Nosač motora

Nosač motora prikazana na slici 3.9 prokazan je nosač motora. Materijal izrade je akril debljine šest milimetara. Isti nosač se koristi za oba motora.

Radionički crtež nalazi se u prilogu [5].

3.1.9 Spojka

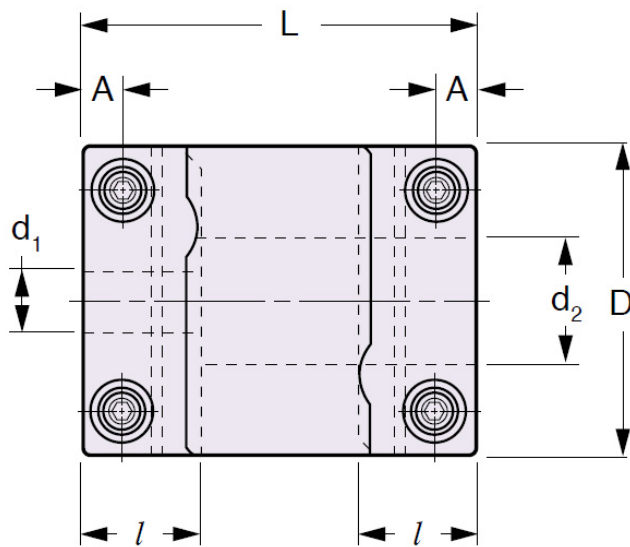

Slika 3.10 Spojka

Na slici 3.10 je prikazana spojka koja služi za spajanje dva motora. Spojka je napravljena od aluminija u kombinaciji sa kaljupljenom gumom. Detaljna specifikacija spojke nalazi se u prilogu, a neke od specifikacija su navedene u tablici 3.3, a detaljni podaci u prilogu [6].

Tablica 3.3 Tehnički podaci spojke

D	15 mm
$d_1=d_2$	4 mm
L	18 mm
l	6.5 mm
A	2.15 mm
Tn	2.3 Nm
Max rpm	25000 rpm
Moment inercije	$2.3 \times 10^{-6} \text{kgm}^2$
Masa	25 g

3.1.10 Spojni elementi

Spojni elementi su na slici 3.2 opisanih u tablici 3.1 na pozicijama od 11-19 načinjeni su od aluminjskog L- profila (DIN 59413 20X20X1.5) a prikazani su na slici 3.11



Slika 3.11 L-profil (HRN DIN 59413 20X20X1.5)

Profili su odbarna radi lakšeg sklapanje te rasklapanja makete. Montaža profila i ostalih elemenata makete vrši se vijcima deklariranim po DIN 7981 [7](tablica 3.4) duljine 9.5mm.

Tablica 3.4 DIN 7981 vijak za lim

DIN 7981 Phillips Pan Head Sheet Metal Screw								
Diameter	M2.2	M2.9	M3.5	M3.9	M4.2	M4.8	M5.5	M6.3
Length								
4.5	0.16							
6.5	0.20	0.40						
9.5	0.26	0.51	0.79	1.05	1.22	1.85		
13	0.33	0.63	0.97	1.27	1.46	2.2	3.2	3.90
16	0.39	0.74	1.12	1.46	1.67	2.5	3.6	4.44
19		0.85	1.27	1.65	1.88	2.8	4.0	4.98
22			1.42	1.84	2.1	3.1	4.38	5.52
25			1.57	2.03	2.3	3.4	4.76	6.06
32					2.8	4.1	5.67	7.32
38						4.7	6.45	8.40

Detaljan opis sa radioničkim crtežama nalazi se u prilogu[6...9].

3.1.11 Napajanje makete



Slika 3.12 Napajenj Traco Power TXL 150-24S

Napajanje makete TXL 150-24S slika 3.12 označeno kao pozicija 20 na slici 3.2 ima neke od karakteristika tablica 3.5 [4]. Nosač napajanja je opisan u radioničkom crtežu [10].

Tablica 3.5 Tehničke karakteristike napajanja TRACO POWER TXL 150-24S

Napon napajanja	85-264 V
Frekvencija ulaza	47-63 Hz
Potrošnja struje	1.15 A
Nazivna snaga	150 W
Izlazni napon	24 V
Izlazna struja	6,3 A
Preporučeni izlazni osigurač	10 A (T)

3.1.12 Regulacijska elektronika

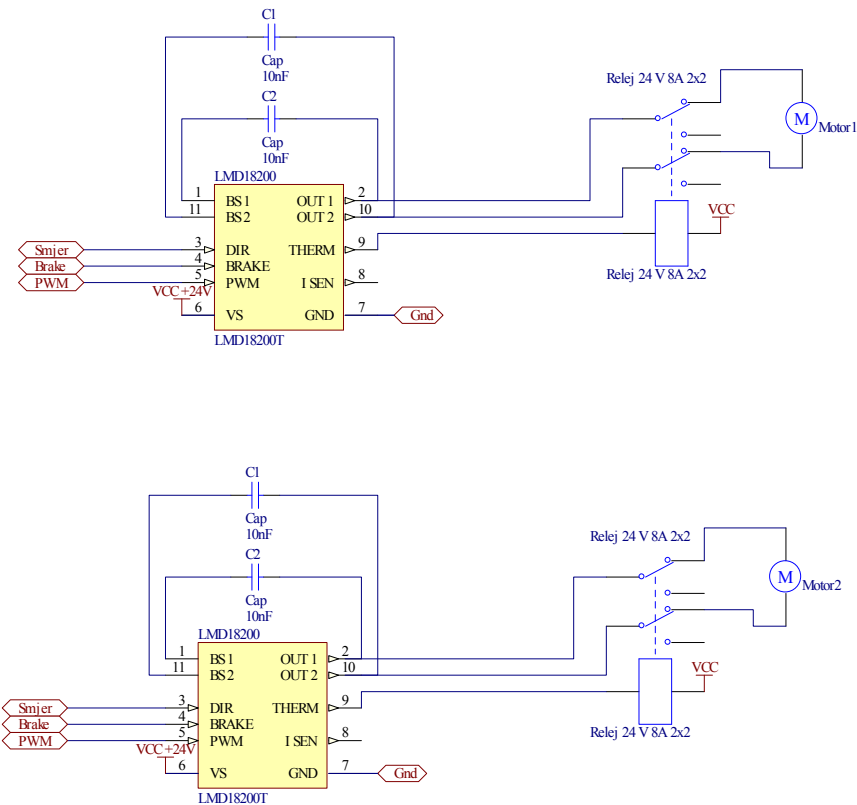

Slika 3.13 Shema spajanja motora

Na slici 3.13 prikazana je shema sklopa za regulaciju motora. Glavni dio sklopa je integrirani krug LM18200T [prilog 2] čija je struktura opisana na slici 3.14. Osmišljena je također i zaštita od pregrijavanja putem releja na čije su mirne kontakte spojeni motori, kada dođe do pregrijavanja dolazi na pin 9 (slika3.13) "0" koja aktivira relej za rasterećenje izlaza.

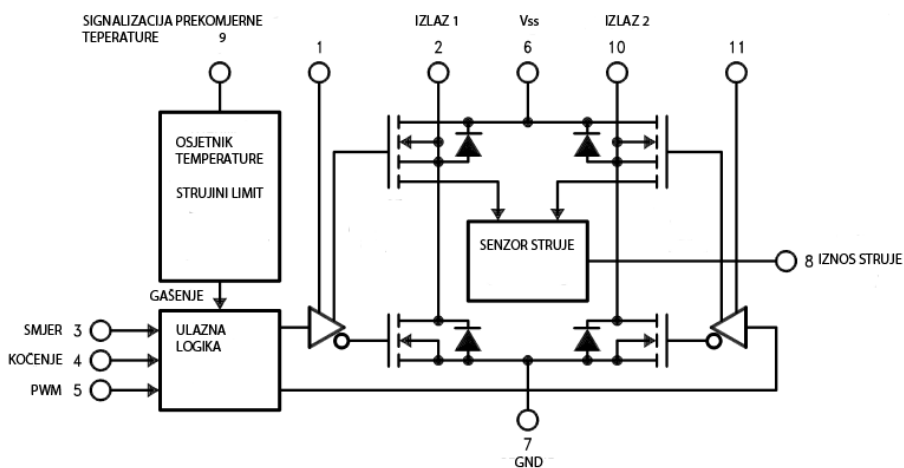

Slika 3.14 Integrirani krug tipa LM 18200

Integrirani krug LM 18200 je H-most jačine 3A osmišljen za regulaciju istosmjernih motora (servo, stepper, brushless...). Koristi CMOS upravljačke tranzistore i DMOS izlazne tranzistore.

Regulacija motora se vrši putem tri ulaza : smjer, kočenje PWM, prikazane na slici 3.15.

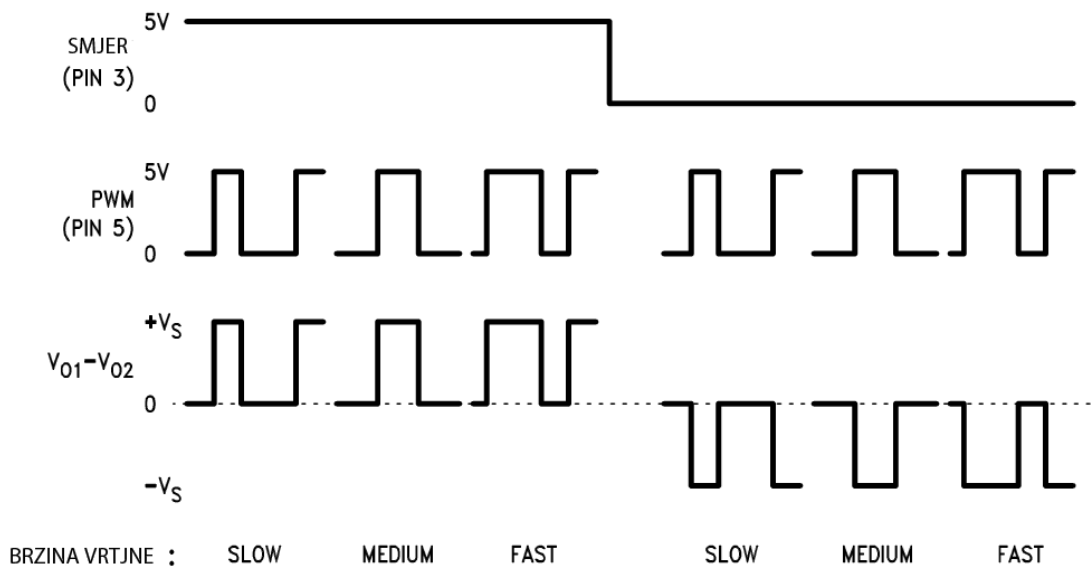

Slika 3.15 Ulazno izlazna karakteristika LM18200T

Ograničenje integriranog kruga je u kočenju motora, nije moguće izvesti kvalitetno generatorsko kočenje dok protustrujno kočenje ima ograničenje struje (nazivna struja 3A).

Kut zakreta motora a time i brzina vrtnje motora očitava se pomoću inkrementalnog davača rezolucije 360 imp./okr. Inkrementalni davač na izlazu daje za "1" min 2V dok za "0" daje max. 0.4 V, PLC- na ulazima prima minimalno 15 V za "1" te max 5V za "0". Evidentno je da su ta dva sustava ne kompatibilna stoga je razvijeno pojačalo na bazi NPN tranzistorske sklopke slika 3.16. PLC ima maksimalnu frekvenciju digitalnog ulaza 20 kHz stoga je maksimalna brzina vrtnje motora ograničena na 3000 okr/min (18kHz)

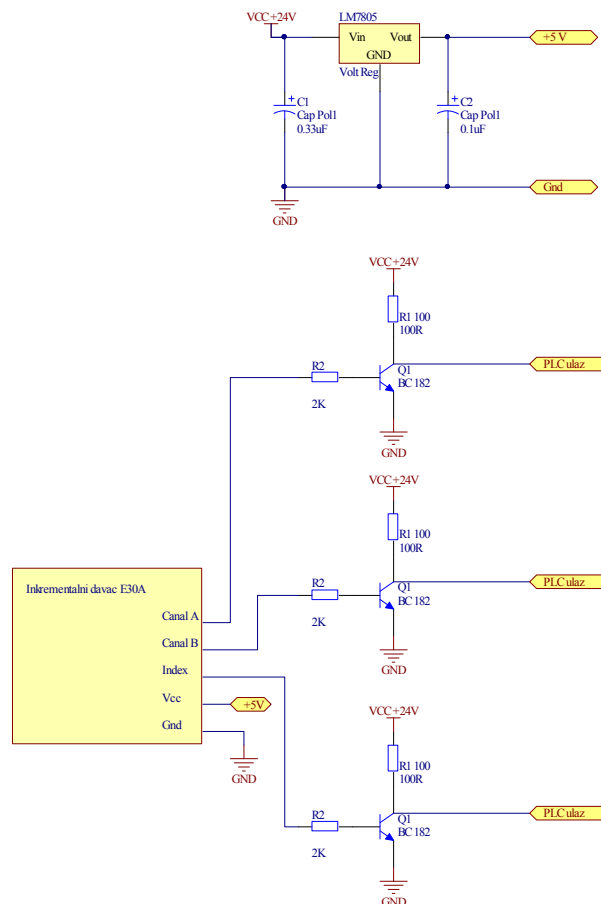

Slika 3.16 Shema sklopa inkrementalnog davača

Sklop inkrementalnog davača sastoji se od tranzistorskog pojačala u spoju zajedničkog emitera[2]. Sklop pojačava ulazni napon od 5V na PLC standardni napon od 24 V. Sklop se sastoji od tranzistora BC182 [5] te dva otpornika za stabilizaciju radne točke [5].

Zaključak

O ovom radu dano je idejno rješenje jednostavne i praktične laboratorijske makete s malim istosmjernim motorima, koja se može koristiti u nastavi iz kolegija iz područja elektrotehnike, mikroprocesorskog upravljanja i regulacije. Kako bi se čim bolje iskoristili postojeći resursi Katedre za strojarsku automatiku (točnije Laboratorija za elektrotehniku) Fakulteta strojarstva i brodogradnje, pri izradi maketa se vodilo računa o kompatibilnosti s postojećom laboratorijskom maketom mikrokontrolerskog sustava sa Simatic S7-200 kontrolerima.

Navedeno rješenje laboratorijske makete predstavlja studiju izvedivosti i kao takvo predstavljat će polaznu točku pri daljnje razvoju nastavnih maketa na Katedri za strojarsku automatiku.

Literatura

- [1] Siemens AG: "SIMATIC S7-200 Programmable Controller System Manual", Edition 08/2005, Germany
- [2] Grilec, Zorc: Osnove elektronike, Školska knjiga, Zagreb 2002.
- [3] <http://www.3ds.com/> - *DASSAULT SYSTEMES*
- [4] Hans Berger: "Automating with Simatic", Siemens AG, 2000, Germany
- [5] Ante Šantić; "Elektronička instrumentacija", Školska knjiga, 1993, Zagreb
- [6] www.altium.com / Altium Designer

Popis priloga

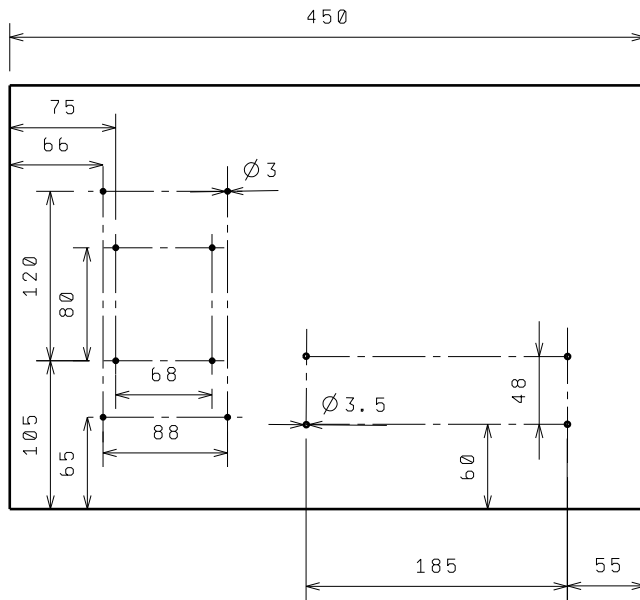

- [1] PITTMANN: "9235 SERIES BRUSH DC SERVO MOTOR, E30B incremental encoder"
- [2] National Semiconductor : "LMD-18200T"
- [3] Winford Engineering: "D-connector"
- [4] Traco Power: "TXL-150-24S"
- [5] Soltem: "MR-21 Rocker switch"
- [6] SDP/SI: " Antivibration Flexible Coupling"
- [7] Sunon: "MagLev Motor AC Fan"

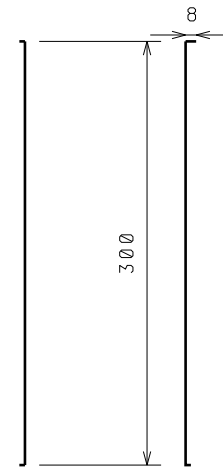

Nacrt
Mjerilo: 1:5

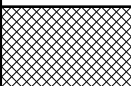

Bokocrt
Mjerilo: 1:5

	Datum	Ime i prezime	Potpis	 FSB Zagreb
Projektirao	14.1.2010	Stjepan Bukal		
Razradio	14.1.2010	Stjepan Bukal		
Crtao	14.1.2010	Stjepan Bukal		
Pregledao				
Objekt:			Objekt broj:	
			R. N. broj:	
Napomena:				Kopija
Materijal: PMMA		Masa: 1,89 kg		
			Pozicija:	Format:
Mjerilo originala: 1:5			Naziv: Glavna ploča	
Crtaj broj:			Listova:	
			List:	

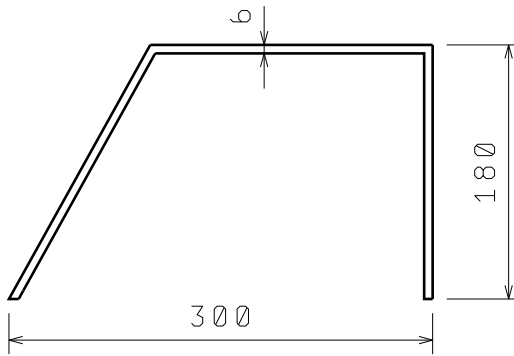

Nacrt
Mjerilo: 1:5

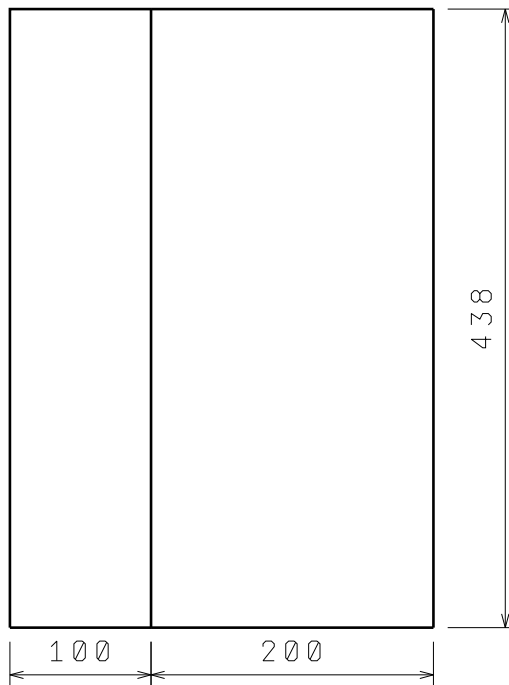

Tlocrt
Mjerilo: 1:5

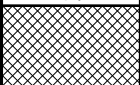
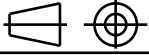
	Datum	Ime i prezime	Potpis	 FSB Zagreb
Projektirao	16.1.2010	Stjepan Bukal		
Razradio	16.1.2010	Stjepan Bukal		
Crtao	16.1.2010	Stjepan Bukal		
Pregledao				
Objekt:			Objekt broj:	
			R. N. broj:	
Napomena:				Kopija
Materijal: poli(metil-metakrilat)		Masa: 1,812kg		
	Naziv: OPLOŠJE		Pozicija:	Format:
Mjerilo originala			2	Listova:
1:5	Crtež broj: 2			List:

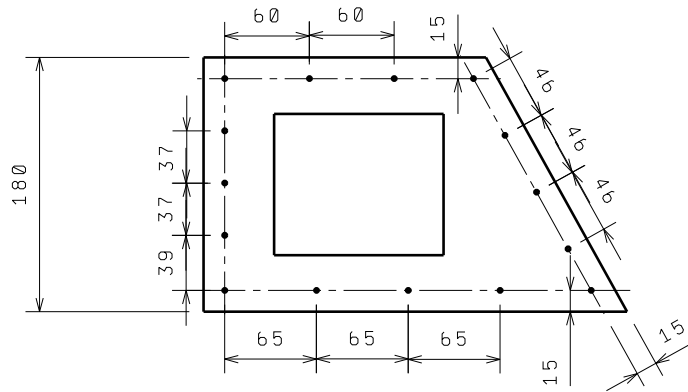

Nacrt
Mjerilo: 1:5

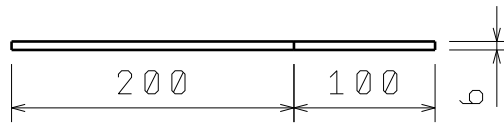

Nacrt
Mjerilo: 1:5

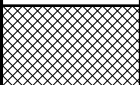
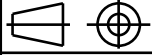
	Datum	Ime i prezime	Potpis	 FSB Zagreb
Projektirao	13.1.2010	Stjepan Bukal		
Razradio	13.1.2010	Stjepan Bukal		
Crtao	13.1.2010	Stjepan Bukal		
Pregledao				
Objekt:			Objekt broj:	
			R. N. broj:	
Napomena:				Kopija
Materijal: PMMA		Masa: 0.081 kg		
 Mjerilo originala: 1:5	Naziv: Bočna strana 2		Pozicija:	Format:
	Crtič broj:			Listova:
				List:

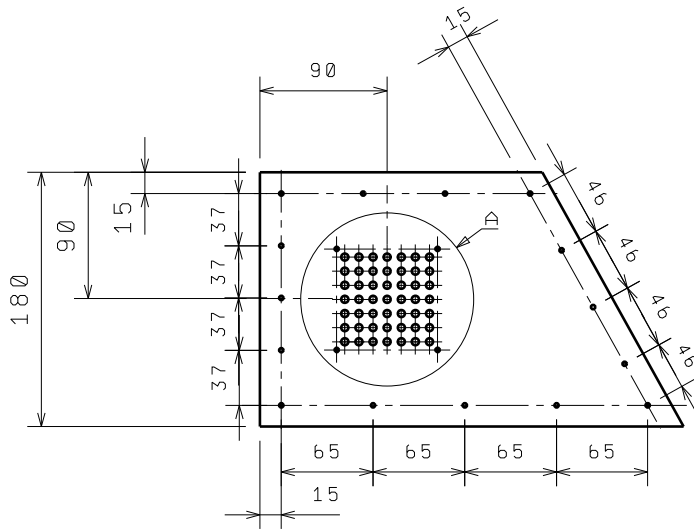

Nacrt
Mjerilo: 1:5

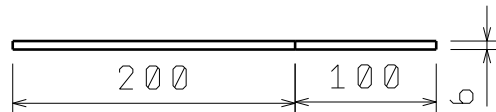

Tlocrt
Mjerilo: 1:5

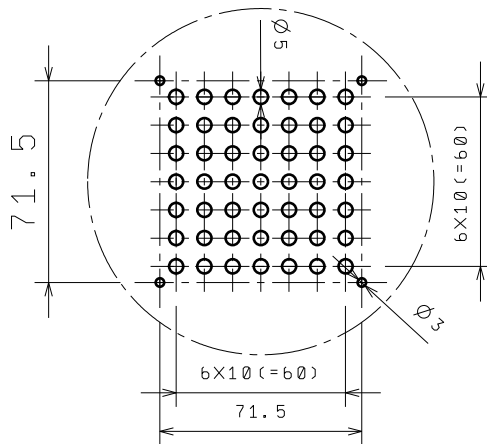

Detalj A
Mjerilo: 2:5

Design by CADLab

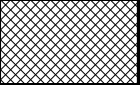
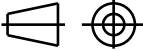
	Datum	Ime i prezime	Potpis	 FSB Zagreb
Projektirao	13.1.2010	Stjepan Bukal		
Razradio	13.1.2010	Stjepan Bukal		
Pregledao				
Crtao	13.1.2010	Stjepan Bukal		
Objekt:			Objekt broj:	
			R. N. broj:	
Napomena:				Kopija
Materijal: poli(metil-metakrilat)		Masa: 0,316 kg		
 Mjerilo originala 1:5	Naziv:		Pozicija:	Format:
	Crtelj broj:3			Listova:1
				List:

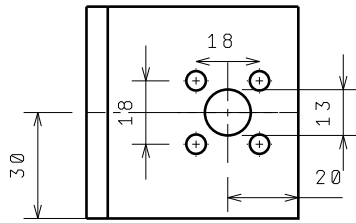

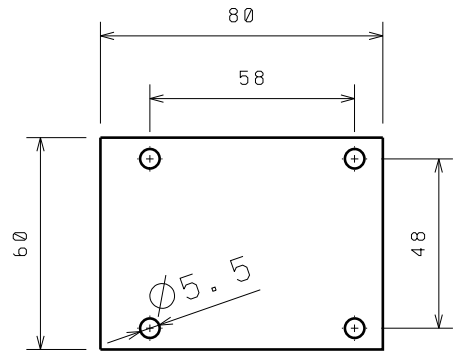

Nacrt
Mjerilo: 1:2



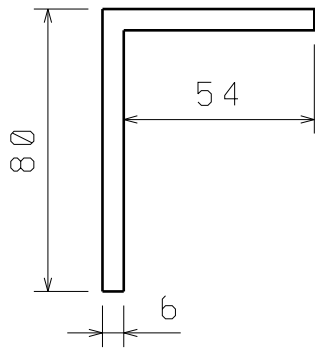

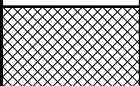

Bokocrt
Mjerilo: 1:2



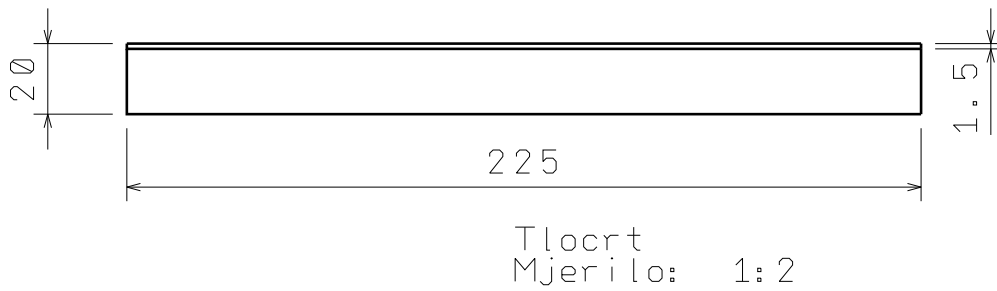

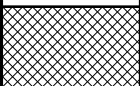

Tlocrt
Mjerilo: 1:2

	Datum	Ime i prezime	Potpis	 FSB Zagreb
Projektirao	14.1.2010	Stjepan Bukal		
Razradio	14.1.2010	Stjepan Bukal		
Crtao	14.1.2010	Stjepan Bukal		
Pregledao				
Objekt:			Objekt broj:	
			R. N. broj:	
Napomena:				Kopija
Materijal: PMMA		Masa: 0,056 kg		
	Naziv: Nosač motora		Pozicija:	Format:
Mjerilo originala: 1:2				Listova:
Crtež broj:				List:

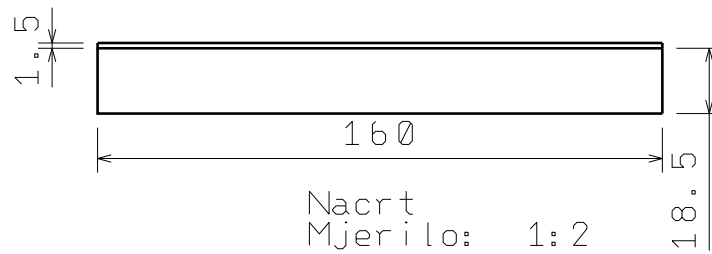

	Datum	Ime i prezime	Potpis	 FSB Zagreb
Projektirao	13.1.2010	Stjepan Bukal		
Razradio	13.1.2010	Stjepan Bukal		
Crtao	13.1.2010	Stjepan Bukal		
Pregledao				
Objekt:			Objekt broj:	
			R. N. broj:	
Napomena:				Kopija
Materijal: Al 99,5 % P.T., AlMg 3		Masa: 0.035 kg		
 Mjerilo originala: 1:2	Naziv: Nosač bočne stranice 1 i 6		Pozicija:	Format:
	Crtič broj:			Listova:
				List:

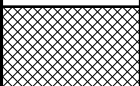



	Datum	Ime i prezime	Potpis	 FSB Zagreb			
Projektirao	13.1.2010	Stjepan Bukal					
Razradio	13.1.2010	Stjepan Bukal					
Crtao	13.1.2010	Stjepan Bukal					
Pregledao							
Objekt:			Objekt broj:				
			R. N. broj:				
Napomena:					Kopija		
Materijal: Al 99,5 % P.T., AlMg 3		Masa: 0.025 kg					
	Naziv: Nosač bočne stranice 4 i 5		Pozicija:	Format:			
Mjerilo originala: 1:2				Listova:			
Crtič broj:					List:		

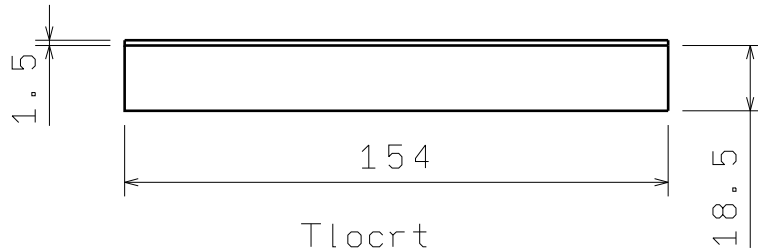

Nacrt
Mjerilo: 1:2

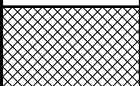

Tlocrt
Mjerilo: 1:2

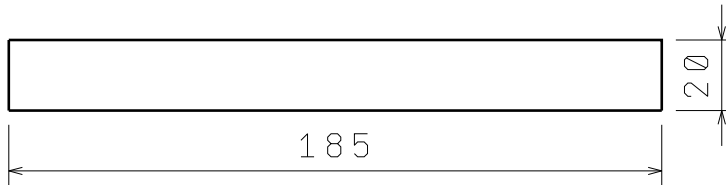

	Datum	Ime i prezime	Potpis	 FSB Zagreb
Projektirao	13.1.2010	Stjepan Bukal		
Razradio	13.1.2010	Stjepan Bukal		
Crtao	13.1.2010	Stjepan Bukal		
Pregledao				
Objekt:			Objekt broj:	
			R. N. broj:	
Napomena:				Kopija
Materijal: Al 99,5 % P.T., AlMg 3		Masa: 0.024 kg		
 Mjerilo originala: 1:2	Naziv: Nosač bočne stranice 7 i 3		Pozicija:	Format:
	Crtič broj:			Listova:
				List:



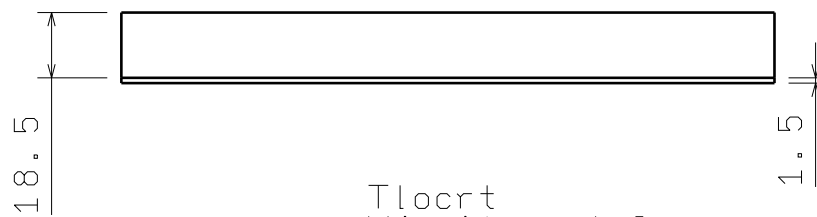

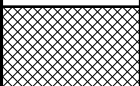

Nacrt
Mjerilo: 1:2

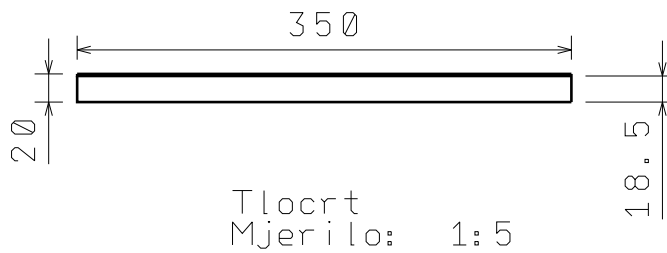

Tlocrt
Mjerilo: 1:2

	Datum	Ime i prezime	Potpis	 FSB Zagreb	
Projektirao	13.1.2010	Stjepan Bukal			
Razradio	13.1.2010	Stjepan Bukal			
Crtao	13.1.2010	Stjepan Bukal			
Pregledao					
Objekt:			Objekt broj:		
			R. N. broj:		
Napomena:				Kopija	
Materijal: Al 99,5 % P.T., AlMg 3				Masa: 0.035 kg	
		Naziv: Nosač bočne stranice 1 i 6		Pozicija:	
Mjerilo originala: 1:2				Format:	
Crtaj broj:				Listova:	
				List:	

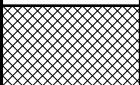

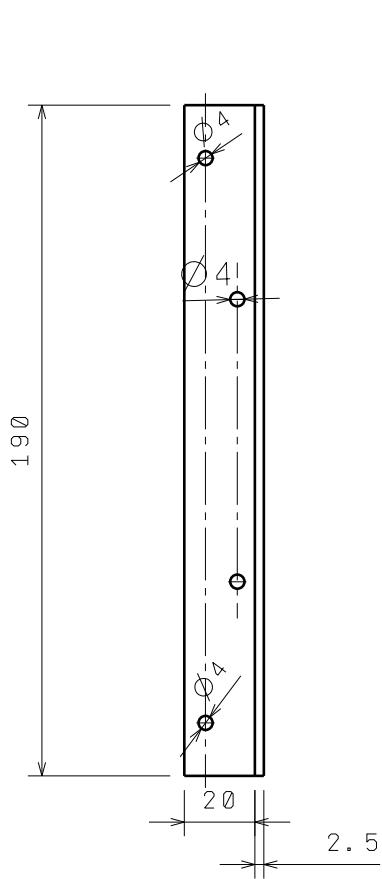

	Datum	Ime i prezime	Potpis	 FSB Zagreb
Projektirao	13.1.2010	Stjepan Bukal		
Razradio	13.1.2010	Stjepan Bukal		
Crtao	13.1.2010	Stjepan Bukal		
Pregledao				
Objekt:			Objekt broj:	
			R. N. broj:	
Napomena:				Kopija
Materijal: Al 99,5 % P.T., AlMg 3		Masa: 0.055 kg		
	Naziv: Nosač zadnje stranice		Pozicija:	Format:
Mjerilo originala: 1:2				Listova:
Crtež broj:				List:

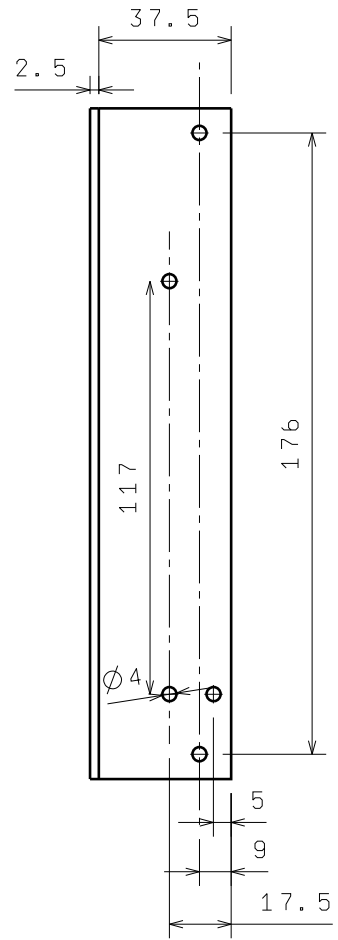

Nacrt
Mjerilo: 1:2

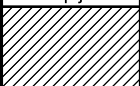

Bokocrt
Mjerilo: 1:2

	Datum	Ime i prezime	Potpis	 FSB Zagreb
Projektirao	9.1.2010	Stjepan Bukal		
Razradio	9.1.2010	Stjepan Bukal		
Crtao	9.1.2010	Stjepan Bukal		
Pregledao				
Objekt:			Objekt broj:	
			R. N. broj:	
Napomena:			Kopija	
Materijal: PMMA			Masa: 0.034 kg	
 	Naziv: Nosač napajanja		Pozicija:	Format:
Mjerilo originala: 1:2				Listova:
Crtež broj:				List:

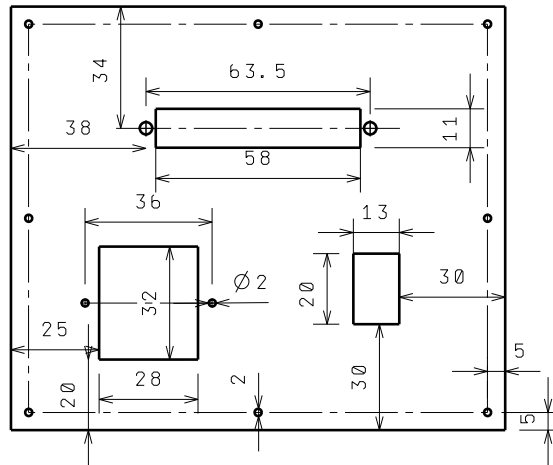

Nacrt
Mjerilo: 1:2

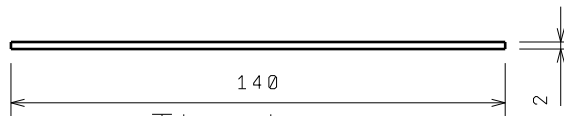

Tlocrt
Mjerilo: 1:2

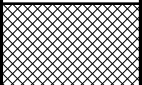
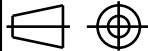
	Datum	Ime i prezime	Potpis	 FSB Zagreb
Projektirao	13.1.2010	Stjepan Bukal		
Razradio	13.1.2010	Stjepan Bukal		
Crtao	13.1.2010	Stjepan Bukal		
Pregledao				
Objekt:			Objekt broj:	
			R. N. broj:	
Napomena:				Kopija
Materijal: Al 99,5 % P.T., AlMg 3		Masa: 0.081 kg		
 Mjerilo originala: 1:2	Naziv: Bočna strana 1		Pozicija:	Format:
	Crtič broj:			Listova:
				List:

9235 SERIES BRUSH DC SERVO MOTOR

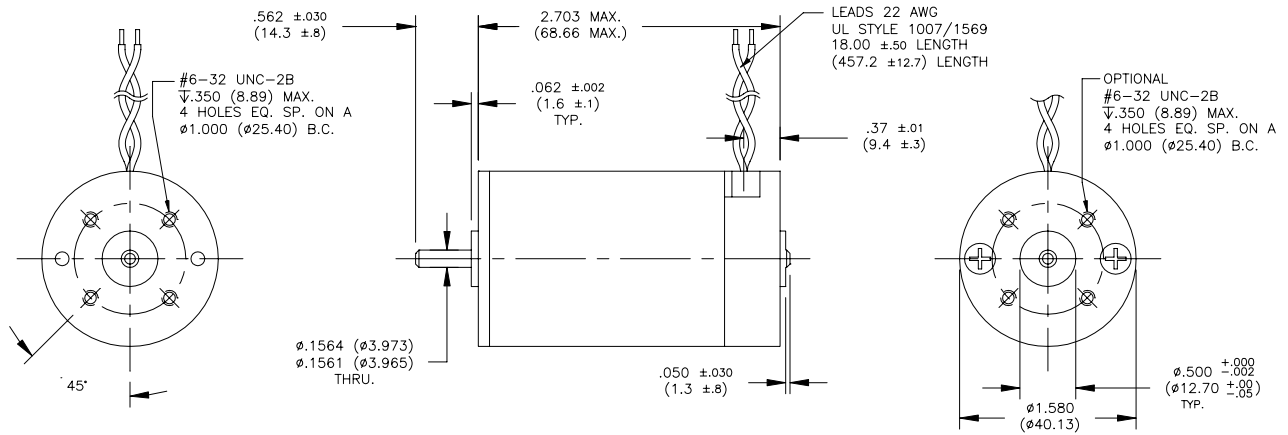

Motor Data	Symbol	Units	Winding Designation							
			9.55 V	12.0 V	15.2 V	19.1 V	24.0 V	30.3 V	38.2 V	48.0 V
Supply Voltage (Reference)	V_s	V	9.55	12.0	15.2	19.1	24.0	30.3	38.2	48.0
Continuous Torque	T_c	oz-in	6.9	6.9	6.9	6.9	6.9	6.9	6.9	6.9
		Nm	0.049	0.049	0.049	0.049	0.049	0.049	0.049	0.049
Speed @ Cont. Torque	S_c	rpm	5220	5610	5800	5850	6000	6030	6070	6050
Current @ Cont. Torque	I_c	A	5.13	4.16	3.27	2.58	2.08	1.64	1.30	1.02
Continuous Output Power	$P_{o.c}$	W	27	29	30	30	31	31	31	31
Motor Constant	K_M	oz-in/ \sqrt{W}	2.9	3.0	3.1	3.2	3.2	3.3	3.3	3.3
		Nm/ \sqrt{W}	0.020	0.021	0.022	0.023	0.023	0.023	0.023	0.023
Torque Constant	K_T	oz-in/A	2.00	2.47	3.14	3.99	4.94	6.27	7.89	9.98
		Nm/A	0.0141	0.0174	0.0222	0.0282	0.0349	0.0443	0.0557	0.0705
Voltage Constant	K_E	V/krpm	1.48	1.83	2.32	2.95	3.65	4.64	5.83	7.38
		V s/rad	0.0141	0.0174	0.0222	0.0282	0.0349	0.0443	0.0557	0.0705
Terminal Resistance	R_{mt}	Ω	0.48	0.68	1.02	1.56	2.37	3.72	5.83	9.23
Inductance	L	mH	0.33	0.51	0.82	1.33	2.05	3.30	5.21	8.35
No-Load Current	I_{nl}	A	0.47	0.38	0.30	0.24	0.19	0.15	0.12	0.090
No-Load Speed	S_{nl}	rpm	6180	6300	6290	6220	6320	6290	6300	6260
Peak Current (Stall)	I_{pk}	A	19.9	17.6	14.9	12.2	10.1	8.15	6.55	5.20
Peak Torque (Stall)	T_{pk}	oz-in	38.9	42.6	45.9	47.9	49.1	50.1	50.8	51.0
		Nm	0.274	0.301	0.324	0.338	0.347	0.354	0.358	0.360
Coulomb Friction Torque	T_f	oz-in	0.65	0.65	0.65	0.65	0.65	0.65	0.65	0.65
		Nm	0.0046	0.0046	0.0046	0.0046	0.0046	0.0046	0.0046	0.0046
Viscous Damping Factor	D	oz-in/krpm	0.045	0.045	0.045	0.045	0.045	0.045	0.045	0.045
		Nm s/rad	3.0E-06	3.0E-06	3.0E-06	3.0E-06	3.0E-06	3.0E-06	3.0E-06	3.0E-06
Electrical Time Constant	τ_e	ms	0.69	0.75	0.80	0.85	0.86	0.89	0.89	0.90
Mechanical Time Constant	τ_m	ms	13	12	12	11	11	11	10	10
Thermal Time Constant	τ_{th}	min	13	13	13	13	13	13	13	13
Thermal Resistance	R_{th}	$^{\circ}C/W$	15	15	15	15	15	15	15	15
Max. Winding Temperature	θ_{max}	$^{\circ}C$	155	155	155	155	155	155	155	155
Rotor Inertia	J_r	oz-in-sec ²	7.9E-04	7.9E-04	7.9E-04	7.9E-04	7.9E-04	7.9E-04	7.9E-04	7.9E-04
		kg m ²	5.6E-06	5.6E-06	5.6E-06	5.6E-06	5.6E-06	5.6E-06	5.6E-06	5.6E-06
Motor Weight (Mass)	w_M	oz	12.0	12.0	12.0	12.0	12.0	12.0	12.0	12.0
		g	340	340	340	340	340	340	340	340

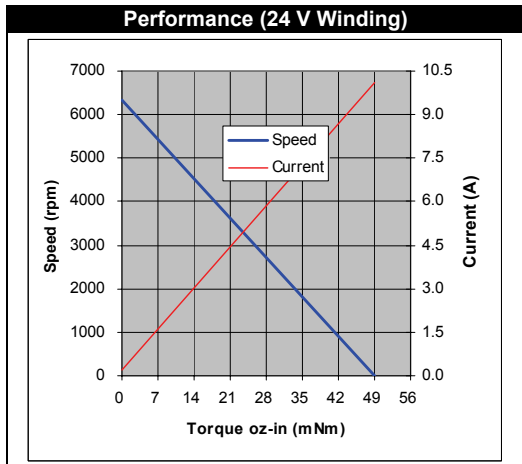

- | Standard Features | |
|----------------------------|-----------------------------|
| • Sintered Bronze Bearings | • Heavy-gauge Steel Housing |
| • 2-pole Stator | • Silicon Steel Laminations |
| • Ceramic Magnets | • Copper-graphite Brushes |
| • 7-slot Armature | • Diamond-Turned Commutator |

- | Complementary Products | |
|--------------------------|------------------------|
| • G42A Planetary Gearbox | • E22A Optical Encoder |
| • G42B Planetary Gearbox | • E30A Optical Encoder |
| • G51A Spur Gearbox | • E30B Optical Encoder |
| | • E35A Optical Encoder |

Notes:
¹ All values specified at 25°C ambient temperature and without heat sink.
² Peak values are theoretical and supplied for reference only.

E30 INCREMENTAL OPTICAL ENCODER

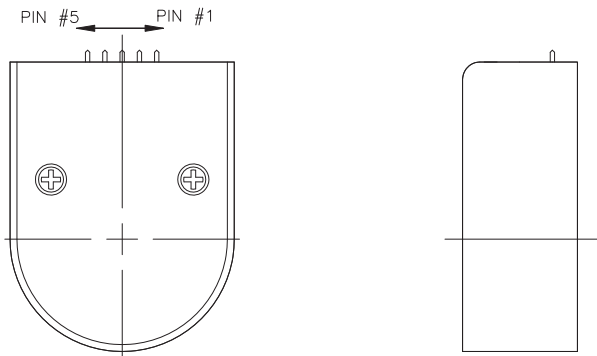

Optional Leadwire Assemblies

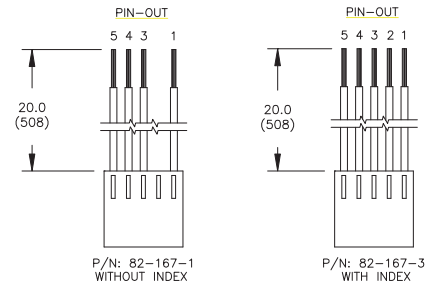

ALL LEADS
24 AWG
UL STYLE
1569

*See individual motor series outline drawings for applicable encoder dimensions

E30A

E30A Encoder Data	Symbol	Units	Value
Available Resolutions	-	-	100, 200, 256, 360, 500, 512, 1000, 1024
Outputs	-	-	2-Channel Quadrature Output
Output Interface	-	-	TTL Compatible
Supply Voltage	V_{cc}	V	4.5 to 5.5
Supply Current	I_{cc}	mA	40 max
High Level Output Voltage	V_{OH}	V	2.4 min
Low Level Output Voltage	V_{OL}	V	0.4 max
Maximum Operating Frequency	f_{max}	kHz	100
Maximum Operating Temperature	θ_{max}	°C	-40 to +100
Encoder Weight (Mass)	w_E	oz g	2.0 57

E30A Connection Chart		
Pin	Color	Function
1	Black	Ground
2	-	No Connection
3	Yellow	Channel A
4	Red	V_{cc}
5	Blue	Channel B

Options	
<ul style="list-style-type: none"> Differential line driver with complementary outputs Alternate leadwire assemblies 	

Notes:

¹ Motor ball bearings are required for optimal performance.

E30B

E30A Encoder Data	Symbol	Units	Value
Available Resolutions	-	-	256, 360, 500, 512
Outputs	-	-	3-Channel Quadrature Output with Index Pulse
Output Interface	-	-	TTL Compatible
Supply Voltage	V_{cc}	V	4.5 to 5.5
Supply Current	I_{cc}	mA	85 max
High Level Output Voltage	V_{OH}	V	2.4 min
Low Level Output Voltage	V_{OL}	V	0.4 max
Maximum Operating Frequency	f_{max}	kHz	100
Maximum Operating Temperature	θ_{max}	°C	-40 to +100
Encoder Weight (Mass)	w_E	oz g	2.0 57

E30B Connection Chart		
Pin	Color	Function
1	Black	Ground
2	Green	Index
3	Yellow	Channel A
4	Red	V_{cc}
5	Blue	Channel B

Options	
<ul style="list-style-type: none"> Differential line driver with complementary outputs Alternate leadwire assemblies 	

Notes:

¹ Motor ball bearings are required for optimal performance.

² 2.7k Ohm pull-up resistors recommended for E30B.

LMD18200

3A, 55V H-Bridge

General Description

The LMD18200 is a 3A H-Bridge designed for motion control applications. The device is built using a multi-technology process which combines bipolar and CMOS control circuitry with DMOS power devices on the same monolithic structure. Ideal for driving DC and stepper motors; the LMD18200 accommodates peak output currents up to 6A. An innovative circuit which facilitates low-loss sensing of the output current has been implemented.

Features

- Delivers up to 3A continuous output
- Operates at supply voltages up to 55V
- Low $R_{DS(ON)}$ typically 0.3Ω per switch
- TTL and CMOS compatible inputs

- No "shoot-through" current
- Thermal warning flag output at 145°C
- Thermal shutdown (outputs off) at 170°C
- Internal clamp diodes
- Shorted load protection
- Internal charge pump with external bootstrap capability

Applications

- DC and stepper motor drives
- Position and velocity servomechanisms
- Factory automation robots
- Numerically controlled machinery
- Computer printers and plotters

Functional Diagram

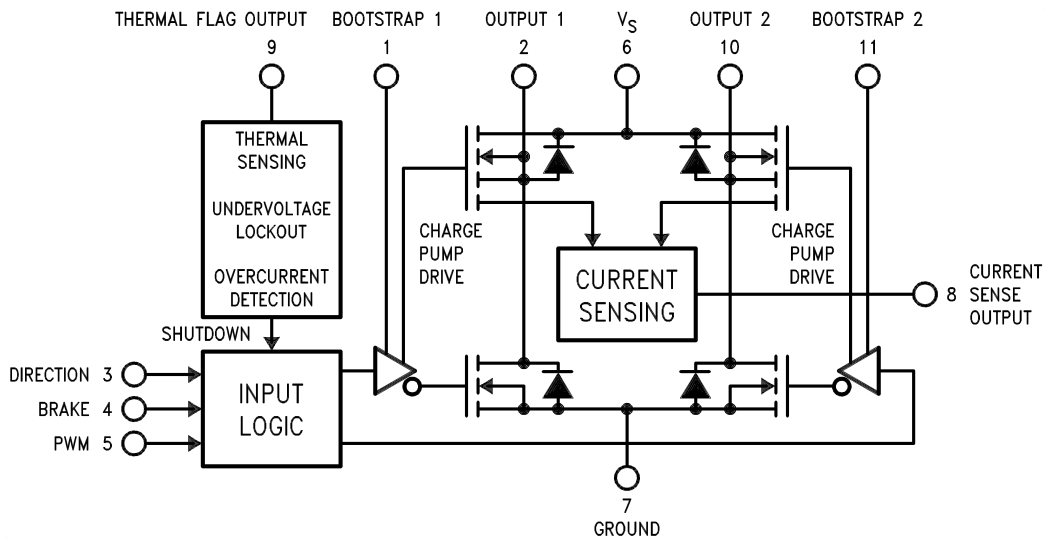

01056801

FIGURE 1. Functional Block Diagram of LMD18200

Connection Diagrams and Ordering Information

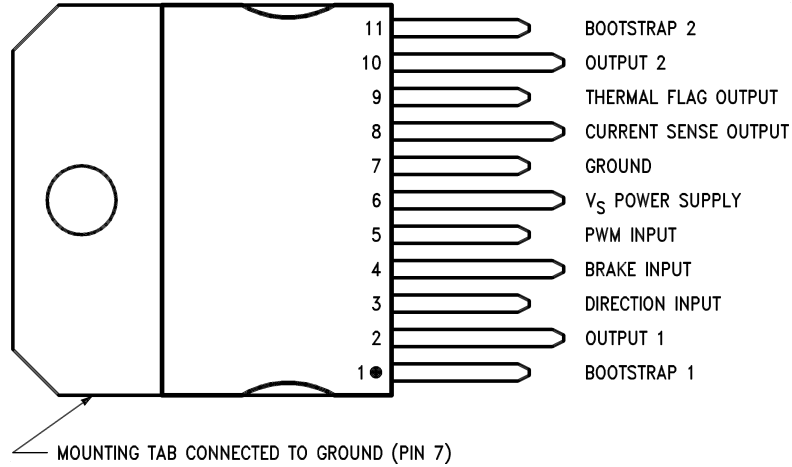

01056802

**11-Lead TO-220 Package
Top View
Order Number LMD18200T
See NS Package TA11B**

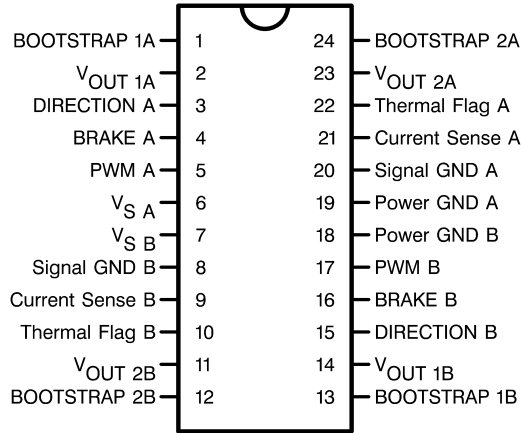

01056825

**24-Lead Dual-in-Line Package
Top View
Order Number LMD18200-2D-QV
5962-9232501VXA
LMD18200-2D/883
5962-9232501MXA
See NS Package DA24B**

Absolute Maximum Ratings (Note 1)

If Military/Aerospace specified devices are required, please contact the National Semiconductor Sales Office/Distributors for availability and specifications.

Total Supply Voltage (V_S , Pin 6)	60V
Voltage at Pins 3, 4, 5, 8 and 9	12V
Voltage at Bootstrap Pins (Pins 1 and 11)	$V_{OUT} + 16V$
Peak Output Current (200 ms)	6A
Continuous Output Current (Note 2)	3A
Power Dissipation (Note 3)	25W

Power Dissipation ($T_A = 25^\circ\text{C}$, Free Air)	3W
Junction Temperature, $T_{J(max)}$	150°C
ESD Susceptibility (Note 4)	1500V
Storage Temperature, T_{STG}	-40°C to +150°C
Lead Temperature (Soldering, 10 sec.)	300°C

Operating Ratings(Note 1)

Junction Temperature, T_J	-40°C to +125°C
V_S Supply Voltage	+12V to +55V

Electrical Characteristics (Note 5)

The following specifications apply for $V_S = 42V$, unless otherwise specified. **Boldface** limits apply over the entire operating temperature range, $-40^\circ\text{C} \leq T_J \leq +125^\circ\text{C}$, all other limits are for $T_A = T_J = 25^\circ\text{C}$.

Symbol	Parameter	Conditions	Typ	Limit	Units
$R_{DS(ON)}$	Switch ON Resistance	Output Current = 3A (Note 6)	0.33	0.4/ 0.6	Ω (max)
$R_{DS(ON)}$	Switch ON Resistance	Output Current = 6A (Note 6)	0.33	0.4/ 0.6	Ω (max)
V_{CLAMP}	Clamp Diode Forward Drop	Clamp Current = 3A (Note 6)	1.2	1.5	V (max)
V_{IL}	Logic Low Input Voltage	Pins 3, 4, 5		-0.1 0.8	V (min) V (max)
I_{IL}	Logic Low Input Current	$V_{IN} = -0.1V$, Pins = 3, 4, 5		-10	μA (max)
V_{IH}	Logic High Input Voltage	Pins 3, 4, 5		2 12	V (min) V (max)
I_{IH}	Logic High Input Current	$V_{IN} = 12V$, Pins = 3, 4, 5		10	μA (max)
	Current Sense Output	$I_{OUT} = 1A$ (Note 8)	377	325/300 425/450	μA (min) μA (max)
	Current Sense Linearity	$1A \leq I_{OUT} \leq 3A$ (Note 7)	± 6	± 9	%
	Undervoltage Lockout	Outputs turn OFF		9 11	V (min) V (max)
T_{JW}	Warning Flag Temperature	Pin 9 $\leq 0.8V$, $I_L = 2\text{ mA}$	145		$^\circ\text{C}$
$V_F(ON)$	Flag Output Saturation Voltage	$T_J = T_{JW}$, $I_L = 2\text{ mA}$	0.15		V
$I_F(OFF)$	Flag Output Leakage	$V_F = 12V$	0.2	10	μA (max)
T_{JSD}	Shutdown Temperature	Outputs Turn OFF	170		$^\circ\text{C}$
I_S	Quiescent Supply Current	All Logic Inputs Low	13	25	mA (max)
t_{Don}	Output Turn-On Delay Time	Sourcing Outputs, $I_{OUT} = 3A$ Sinking Outputs, $I_{OUT} = 3A$	300 300		ns ns
t_{on}	Output Turn-On Switching Time	Bootstrap Capacitor = 10 nF Sourcing Outputs, $I_{OUT} = 3A$ Sinking Outputs, $I_{OUT} = 3A$	100 80		ns ns
t_{Doff}	Output Turn-Off Delay Times	Sourcing Outputs, $I_{OUT} = 3A$ Sinking Outputs, $I_{OUT} = 3A$	200 200		ns ns
t_{off}	Output Turn-Off Switching Times	Bootstrap Capacitor = 10 nF Sourcing Outputs, $I_{OUT} = 3A$ Sinking Outputs, $I_{OUT} = 3A$	75 70		ns ns
t_{pw}	Minimum Input Pulse Width	Pins 3, 4 and 5	1		μs
t_{cpr}	Charge Pump Rise Time	No Bootstrap Capacitor	20		μs

Electrical Characteristics Notes

Note 1: Absolute Maximum Ratings indicate limits beyond which damage to the device may occur. DC and AC electrical specifications do not apply when operating the device beyond its rated operating conditions.

Note 2: See Application Information for details regarding current limiting.

Note 3: The maximum power dissipation must be derated at elevated temperatures and is a function of $T_{J(max)}$, θ_{JA} , and T_A . The maximum allowable power dissipation at any temperature is $P_{D(max)} = (T_{J(max)} - T_A)/\theta_{JA}$, or the number given in the Absolute Ratings, whichever is lower. The typical thermal resistance from junction to case (θ_{JC}) is 1.0°C/W and from junction to ambient (θ_{JA}) is 30°C/W. For guaranteed operation $T_{J(max)} = 125^\circ\text{C}$.

Note 4: Human-body model, 100 pF discharged through a 1.5 kΩ resistor. Except Bootstrap pins (pins 1 and 11) which are protected to 1000V of ESD.

Note 5: All limits are 100% production tested at 25°C. Temperature extreme limits are guaranteed via correlation using accepted SQC (Statistical Quality Control) methods. All limits are used to calculate AOQL, (Average Outgoing Quality Level).

Note 6: Output currents are pulsed ($t_W < 2$ ms, Duty Cycle $< 5\%$).

Note 7: Regulation is calculated relative to the current sense output value with a 1A load.

Note 8: Selections for tighter tolerance are available. Contact factory.

Typical Performance Characteristics

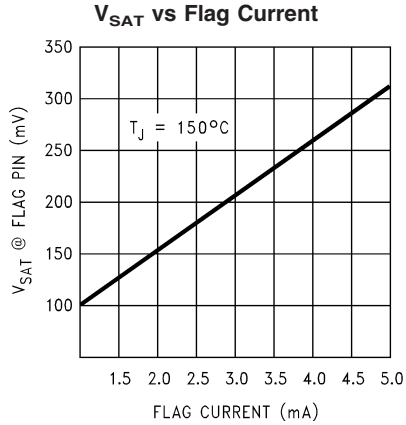

01056816

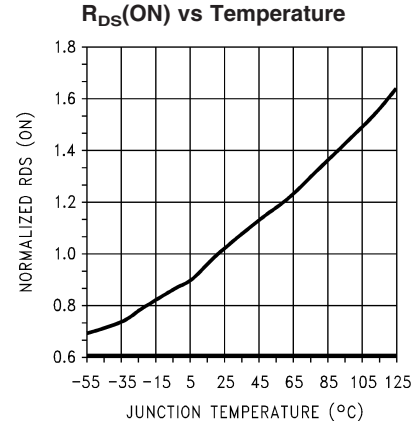

01056817

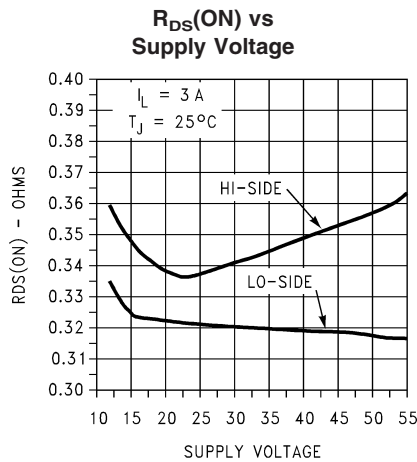

01056818

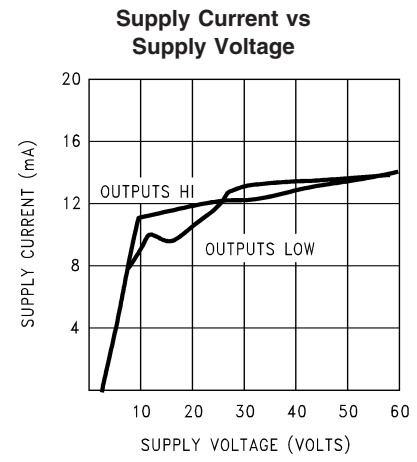

01056819

Typical Performance Characteristics (Continued)

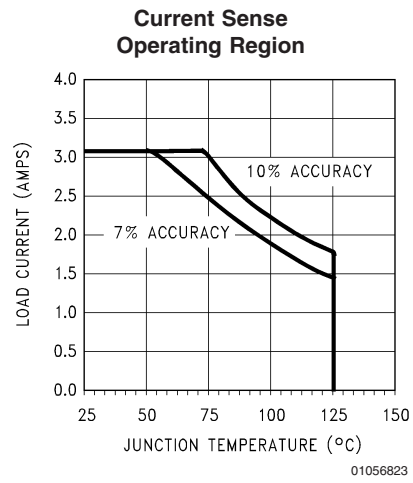
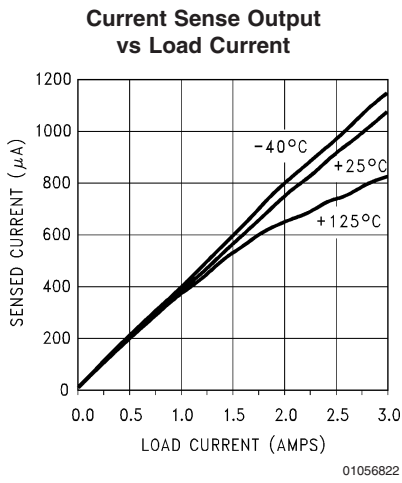
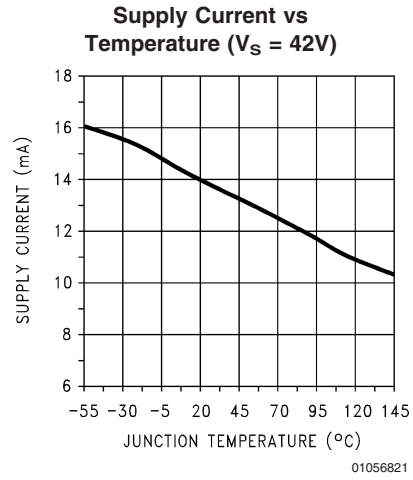
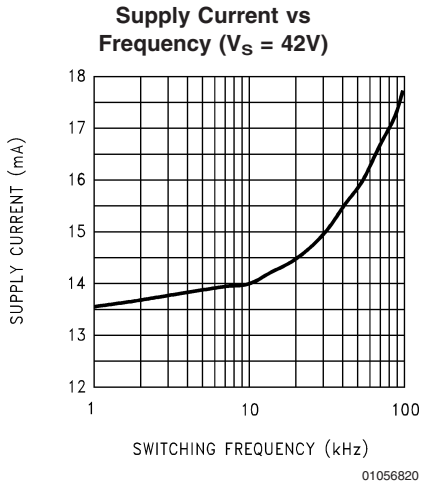

Test Circuit

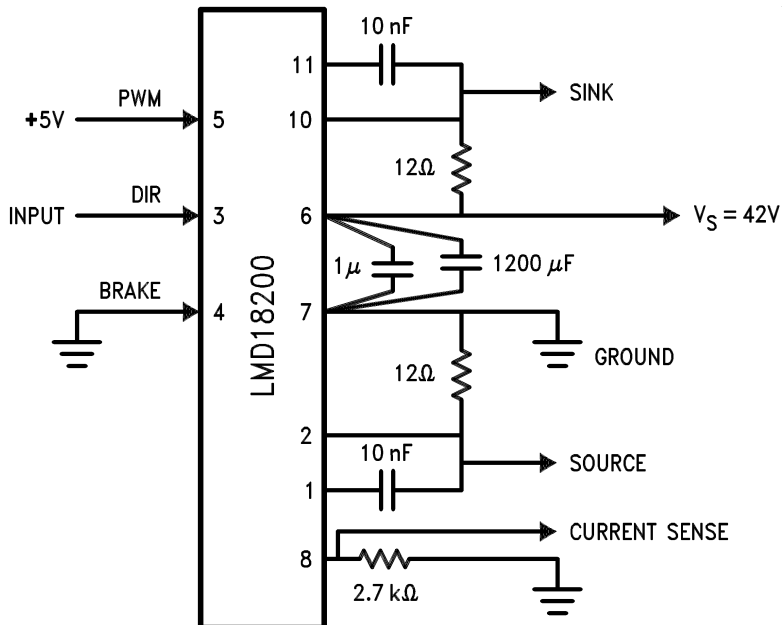

Switching Time Definitions

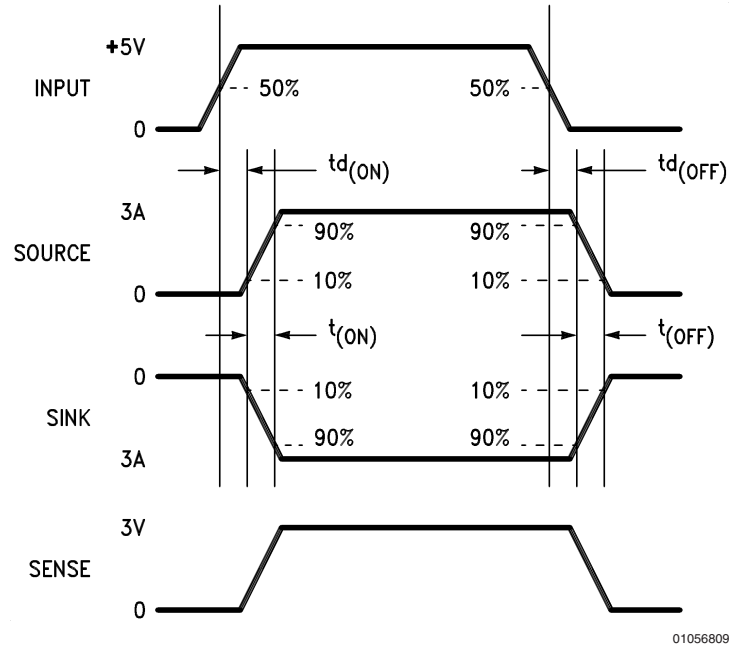

01056809

Pinout Description

(See Connection Diagram)

Pin 1, BOOTSTRAP 1 Input: Bootstrap capacitor pin for half H-bridge number 1. The recommended capacitor (10 nF) is connected between pins 1 and 2.

Pin 2, OUTPUT 1: Half H-bridge number 1 output.

Pin 3, DIRECTION Input: See *Table 1*. This input controls the direction of current flow between OUTPUT 1 and OUTPUT 2 (pins 2 and 10) and, therefore, the direction of rotation of a motor load.

Pin 4, BRAKE Input: See *Table 1*. This input is used to brake a motor by effectively shorting its terminals. When braking is desired, this input is taken to a logic high level and it is also necessary to apply logic high to PWM input, pin 5. The drivers that short the motor are determined by the logic level at the DIRECTION input (Pin 3): with Pin 3 logic high, both current sourcing output transistors are ON; with Pin 3 logic low, both current sinking output transistors are ON. All output transistors can be turned OFF by applying a logic high to Pin 4 and a logic low to PWM input Pin 5; in this case only a small bias current (approximately -1.5 mA) exists at each output pin.

Pin 5, PWM Input: See *Table 1*. How this input (and DIRECTION input, Pin 3) is used is determined by the format of the PWM Signal.

Pin 6, V_S Power Supply

Pin 7, GROUND Connection: This pin is the ground return, and is internally connected to the mounting tab.

Pin 8, CURRENT SENSE Output: This pin provides the sourcing current sensing output signal, which is typically 377 μ A/A.

Pin 9, THERMAL FLAG Output: This pin provides the thermal warning flag output signal. Pin 9 becomes active-low at 145°C (junction temperature). However the chip will not shut itself down until 170°C is reached at the junction.

Pin 10, OUTPUT 2: Half H-bridge number 2 output.

Pin 11, BOOTSTRAP 2 Input: Bootstrap capacitor pin for Half H-bridge number 2. The recommended capacitor (10 nF) is connected between pins 10 and 11.

TABLE 1. Logic Truth Table

PWM	Dir	Brake	Active Output Drivers
H	H	L	Source 1, Sink 2
H	L	L	Sink 1, Source 2
L	X	L	Source 1, Source 2
H	H	H	Source 1, Source 2
H	L	H	Sink 1, Sink 2
L	X	H	NONE

Application Information

TYPES OF PWM SIGNALS

The LMD18200 readily interfaces with different forms of PWM signals. Use of the part with two of the more popular forms of PWM is described in the following paragraphs.

Simple, locked anti-phase PWM consists of a single, variable duty-cycle signal in which is encoded both direction and amplitude information (see *Figure 2*). A 50% duty-cycle PWM signal represents zero drive, since the net value of voltage (integrated over one period) delivered to the load is zero. For the LMD18200, the PWM signal drives the direction input (pin 3) and the PWM input (pin 5) is tied to logic high.

Application Information (Continued)

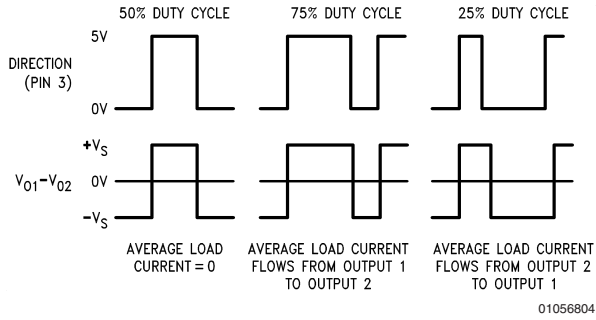

FIGURE 2. Locked Anti-Phase PWM Control

Sign/magnitude PWM consists of separate direction (sign) and amplitude (magnitude) signals (see *Figure 3*). The (absolute) magnitude signal is duty-cycle modulated, and the absence of a pulse signal (a continuous logic low level) represents zero drive. Current delivered to the load is proportional to pulse width. For the LMD18200, the DIRECTION input (pin 3) is driven by the sign signal and the PWM input (pin 5) is driven by the magnitude signal.

SIGNAL TRANSITION REQUIREMENTS

To ensure proper internal logic performance, it is good practice to avoid aligning the falling and rising edges of input signals. A delay of at least 1 μ sec should be incorporated between transitions of the Direction, Brake, and/or PWM input signals. A conservative approach is be sure there is at least 500ns delay between the end of the first transition and the beginning of the second transition. See *Figure 4*.

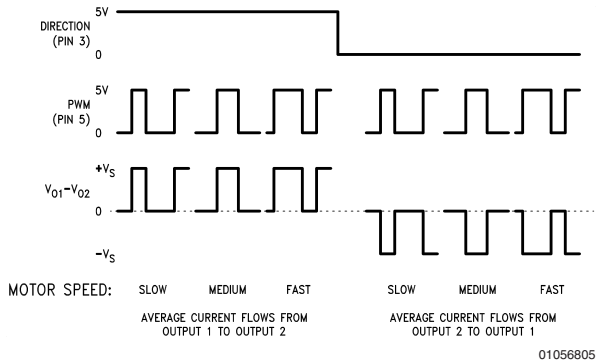

FIGURE 3. Sign/Magnitude PWM Control

Application Information (Continued)

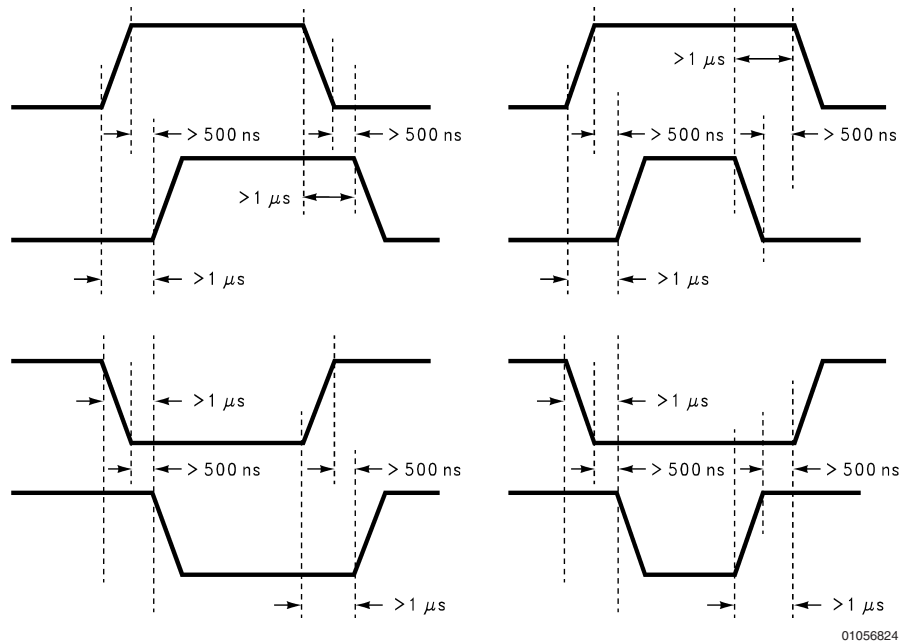

FIGURE 4. Transitions in Brake, Direction, or PWM Must Be Separated By At Least 1 μsec

USING THE CURRENT SENSE OUTPUT

The CURRENT SENSE output (pin 8) has a sensitivity of 377 μA per ampere of output current. For optimal accuracy and linearity of this signal, the value of voltage generating resistor between pin 8 and ground should be chosen to limit the maximum voltage developed at pin 8 to 5V, or less. The maximum voltage compliance is 12V.

It should be noted that the recirculating currents (free wheeling currents) are ignored by the current sense circuitry. Therefore, only the currents in the upper sourcing outputs are sensed.

USING THE THERMAL WARNING FLAG

The THERMAL FLAG output (pin 9) is an open collector transistor. This permits a wired OR connection of thermal warning flag outputs from multiple LMD18200's, and allows the user to set the logic high level of the output signal swing to match system requirements. This output typically drives the interrupt input of a system controller. The interrupt service routine would then be designed to take appropriate steps, such as reducing load currents or initiating an orderly system shutdown. The maximum voltage compliance on the flag pin is 12V.

SUPPLY BYPASSING

During switching transitions the levels of fast current changes experienced may cause troublesome voltage transients across system stray inductance.

It is normally necessary to bypass the supply rail with a high quality capacitor(s) connected as close as possible to the V_S Power Supply (Pin 6) and GROUND (Pin 7). A 1 μF high-frequency ceramic capacitor is recommended. Care should be taken to limit the transients on the supply pin below the Absolute Maximum Rating of the device. When operating the chip at supply voltages above 40V a voltage suppressor

(transorb) such as P6KE62A is recommended from supply to ground. Typically the ceramic capacitor can be eliminated in the presence of the voltage suppressor. Note that when driving high load currents a greater amount of supply bypass capacitance (in general at least 100 μF per Amp of load current) is required to absorb the recirculating currents of the inductive loads.

CURRENT LIMITING

Current limiting protection circuitry has been incorporated into the design of the LMD18200. With any power device it is important to consider the effects of the substantial surge currents through the device that may occur as a result of shorted loads. The protection circuitry monitors this increase in current (the threshold is set to approximately 10 Amps) and shuts off the power device as quickly as possible in the event of an overload condition. In a typical motor driving application the most common overload faults are caused by shorted motor windings and locked rotors. Under these conditions the inductance of the motor (as well as any series inductance in the V_{CC} supply line) serves to reduce the magnitude of a current surge to a safe level for the LMD18200. Once the device is shut down, the control circuitry will periodically try to turn the power device back on. This feature allows the immediate return to normal operation in the event that the fault condition has been removed. While the fault remains however, the device will cycle in and out of thermal shutdown. This can create voltage transients on the V_{CC} supply line and therefore proper supply bypassing techniques are required.

The most severe condition for any power device is a direct, hard-wired ("screwdriver") long term short from an output to ground. This condition can generate a surge of current through the power device on the order of 15 Amps and require the die and package to dissipate up to 500 Watts of power for the short time required for the protection circuitry

Application Information (Continued)

to shut off the power device. This energy can be destructive, particularly at higher operating voltages (>30V) so some precautions are in order. Proper heat sink design is essential and it is normally necessary to heat sink the V_{CC} supply pin (pin 6) with 1 square inch of copper on the PCB.

INTERNAL CHARGE PUMP AND USE OF BOOTSTRAP CAPACITORS

To turn on the high-side (sourcing) DMOS power devices, the gate of each device must be driven approximately 8V more positive than the supply voltage. To achieve this an internal charge pump is used to provide the gate drive voltage. As shown in *Figure 5*, an internal capacitor is alternately switched to ground and charged to about 14V, then switched to V supply thereby providing a gate drive voltage greater than V supply. This switching action is controlled by a continuously running internal 300 kHz oscillator. The rise time of this drive voltage is typically 20 μ s which is suitable for operating frequencies up to 1 kHz.

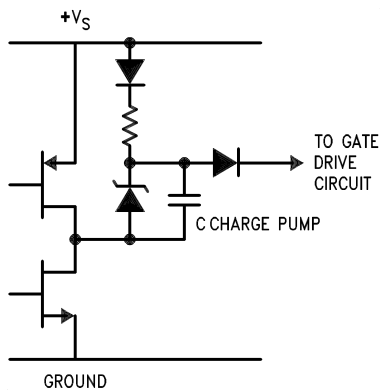

01056806

FIGURE 5. Internal Charge Pump Circuitry

For higher switching frequencies, the LMD18200 provides for the use of external bootstrap capacitors. The bootstrap principle is in essence a second charge pump whereby a large value capacitor is used which has enough energy to quickly charge the parasitic gate input capacitance of the power device resulting in much faster rise times. The switching action is accomplished by the power switches themselves *Figure 6*. External 10 nF capacitors, connected from the outputs to the bootstrap pins of each high-side switch provide typically less than 100 ns rise times allowing switching frequencies up to 500 kHz.

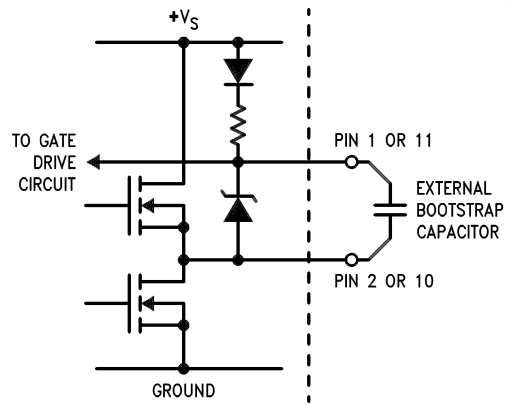

01056807

FIGURE 6. Bootstrap Circuitry

INTERNAL PROTECTION DIODES

A major consideration when switching current through inductive loads is protection of the switching power devices from the large voltage transients that occur. Each of the four switches in the LMD18200 have a built-in protection diode to clamp transient voltages exceeding the positive supply or ground to a safe diode voltage drop across the switch.

The reverse recovery characteristics of these diodes, once the transient has subsided, is important. These diodes must come out of conduction quickly and the power switches must be able to conduct the additional reverse recovery current of the diodes. The reverse recovery time of the diodes protecting the sourcing power devices is typically only 70 ns with a reverse recovery current of 1A when tested with a full 6A of forward current through the diode. For the sinking devices the recovery time is typically 100 ns with 4A of reverse current under the same conditions.

Typical Applications

FIXED OFF-TIME CONTROL

This circuit controls the current through the motor by applying an average voltage equal to zero to the motor terminals for a fixed period of time, whenever the current through the motor exceeds the commanded current. This action causes the motor current to vary slightly about an externally controlled average level. The duration of the Off-period is adjusted by the resistor and capacitor combination of the LM555. In this circuit the Sign/Magnitude mode of operation is implemented (see Types of PWM Signals).

Typical Applications (Continued)

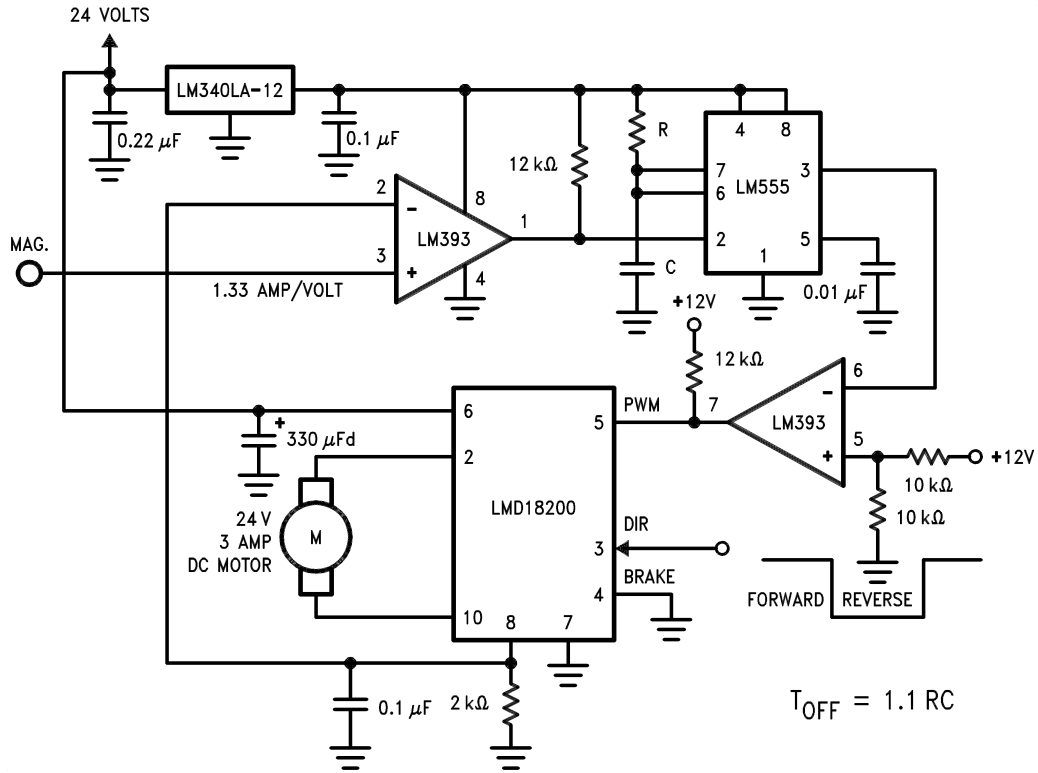

01056810

FIGURE 7. Fixed Off-Time Control

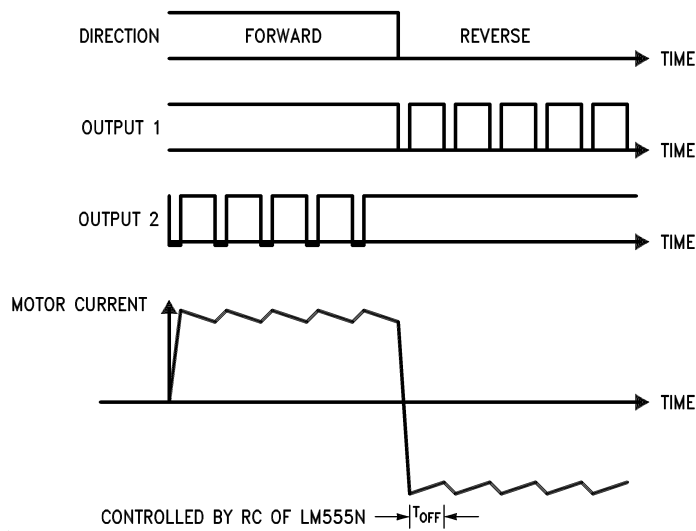

01056811

FIGURE 8. Switching Waveforms

TORQUE REGULATION

Locked Anti-Phase Control of a brushed DC motor. Current sense output of the LMD18200 provides load sensing. The LM3524D is a general purpose PWM controller. The relationship of peak motor current to adjustment voltage is shown in Figure 10.

Typical Applications (Continued)

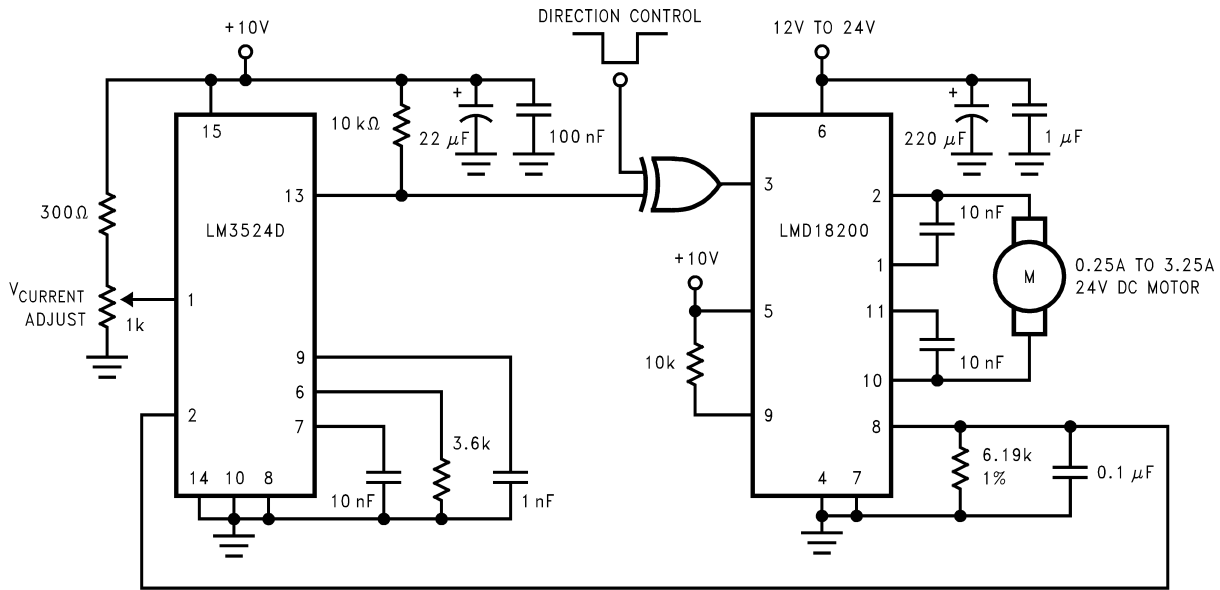

01056812

FIGURE 9. Locked Anti-Phase Control Regulates Torque

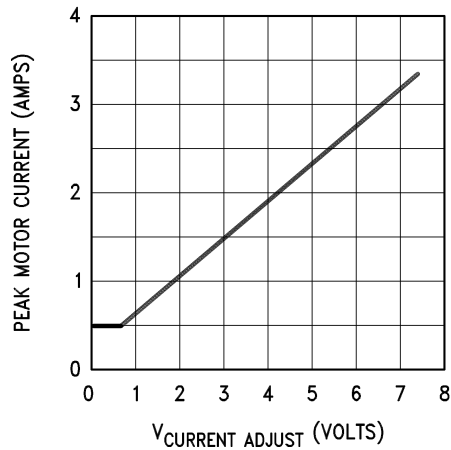

01056813

FIGURE 10. Peak Motor Current vs Adjustment Voltage

VELOCITY REGULATION

Utilizes tachometer output from the motor to sense motor speed for a locked anti-phase control loop. The relationship of motor speed to the speed adjustment control voltage is shown in Figure 12.

Typical Applications (Continued)

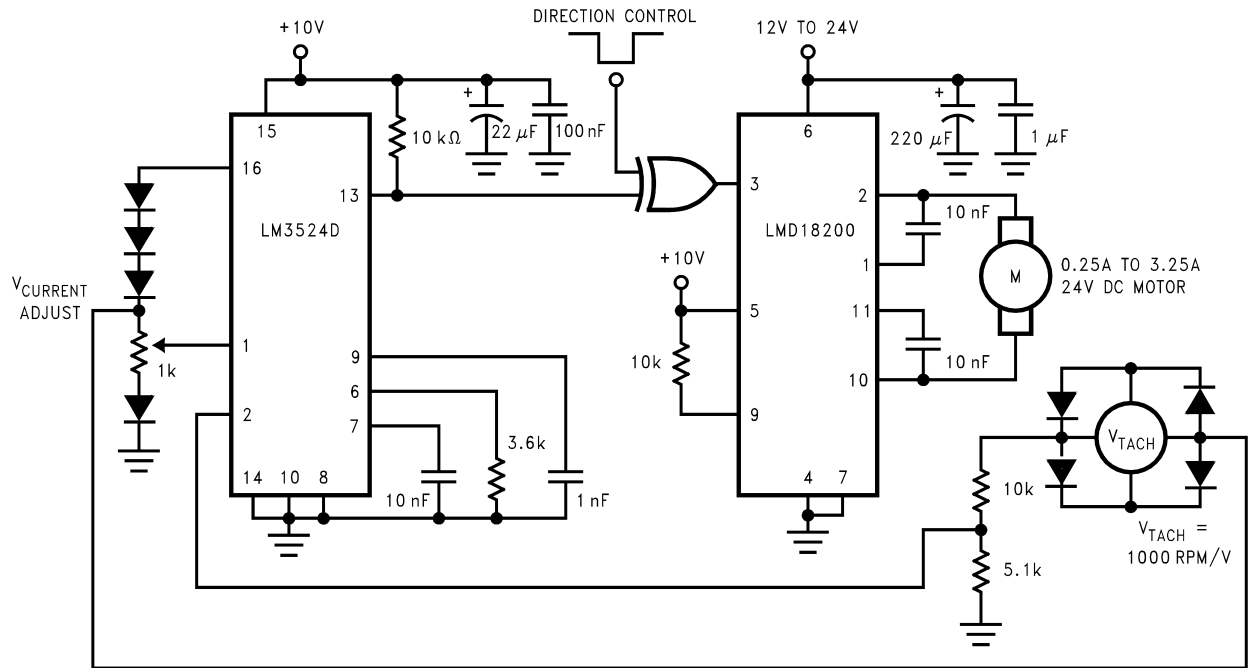

01056814

FIGURE 11. Regulate Velocity with Tachometer Feedback

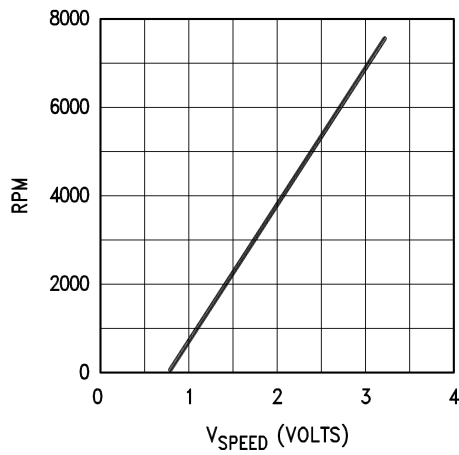

01056815

FIGURE 12. Motor Speed vs Control Voltage

Physical Dimensions inches (millimeters)

unless otherwise noted

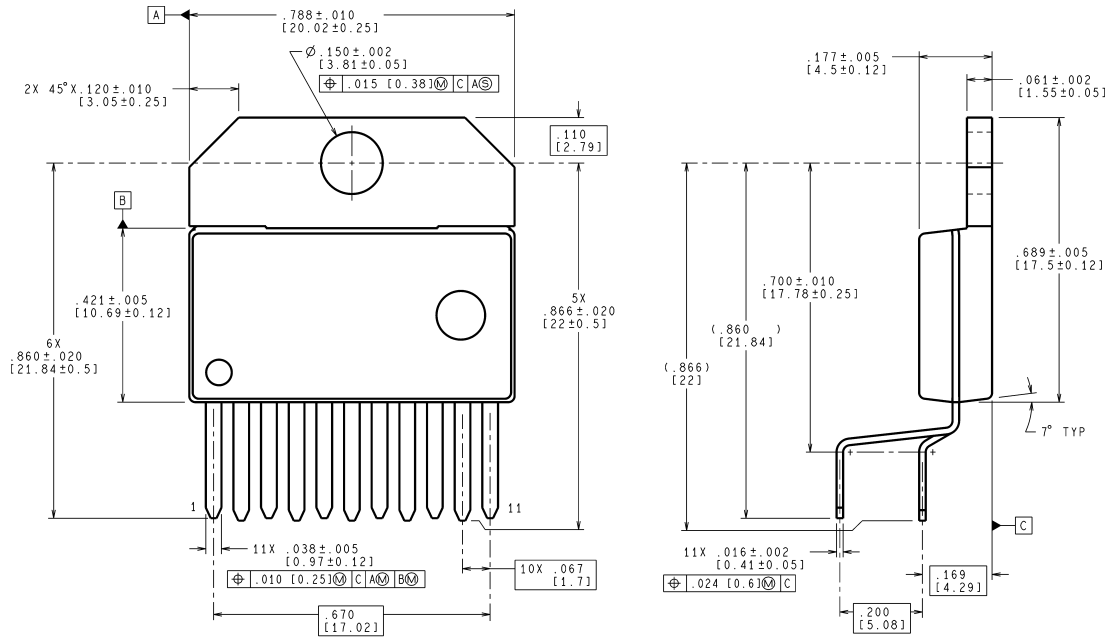

CONTROLLING DIMENSION IS INCH
VALUES IN [] ARE MILLIMETERS

TA11B (Rev B)

11-Lead TO-220 Power Package (T)
Order Number LMD18200T
NS Package Number TA11B

Physical Dimensions inches (millimeters) unless otherwise noted (Continued)

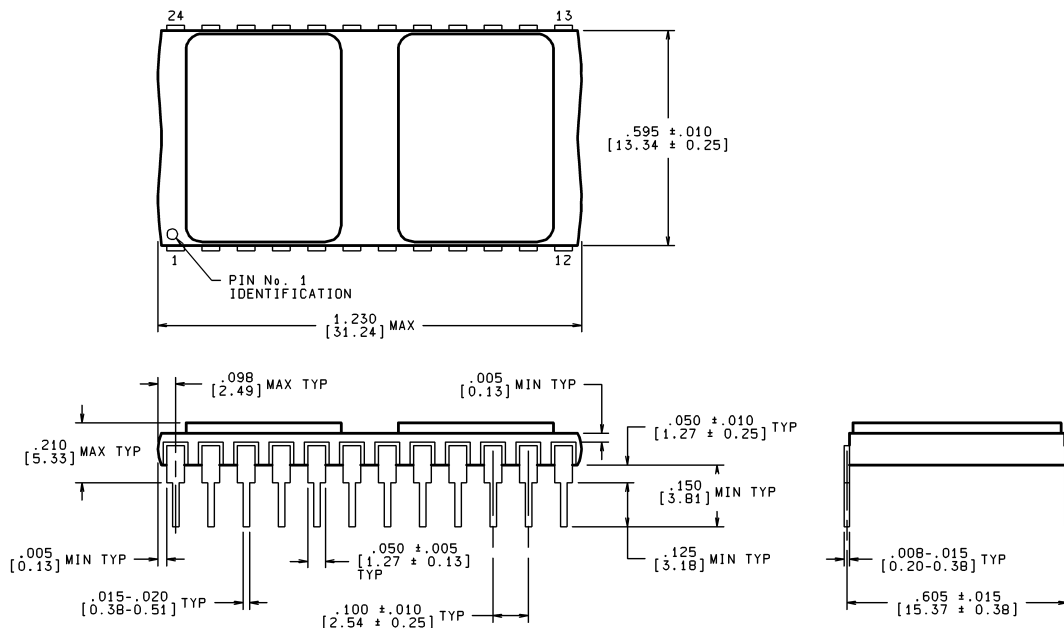

CONTROLLING DIMENSION IS INCH
VALUES IN [] ARE MILLIMETERS

DA24B (Rev A)

24-Lead Dual-in-Line Package
Order Number LMD18200-2D-QV
5962-9232501VXA
LMD18200-2D/883
5962-9232501MXA
NS Package Number DA24B

National does not assume any responsibility for use of any circuitry described, no circuit patent licenses are implied and National reserves the right at any time without notice to change said circuitry and specifications.

For the most current product information visit us at www.national.com.

LIFE SUPPORT POLICY

NATIONAL'S PRODUCTS ARE NOT AUTHORIZED FOR USE AS CRITICAL COMPONENTS IN LIFE SUPPORT DEVICES OR SYSTEMS WITHOUT THE EXPRESS WRITTEN APPROVAL OF THE PRESIDENT AND GENERAL COUNSEL OF NATIONAL SEMICONDUCTOR CORPORATION. As used herein:

1. Life support devices or systems are devices or systems which, (a) are intended for surgical implant into the body, or (b) support or sustain life, and whose failure to perform when properly used in accordance with instructions for use provided in the labeling, can be reasonably expected to result in a significant injury to the user.
2. A critical component is any component of a life support device or system whose failure to perform can be reasonably expected to cause the failure of the life support device or system, or to affect its safety or effectiveness.

BANNED SUBSTANCE COMPLIANCE

National Semiconductor manufactures products and uses packing materials that meet the provisions of the Customer Products Stewardship Specification (CSP-9-111C2) and the Banned Substances and Materials of Interest Specification (CSP-9-111S2) and contain no "Banned Substances" as defined in CSP-9-111S2.

 **National Semiconductor**
Americas Customer
Support Center
 Email: new.feedback@nsc.com
 Tel: 1-800-272-9959

National Semiconductor
Europe Customer Support Center
 Fax: +49 (0) 180-530 85 86
 Email: europa.support@nsc.com
 Deutsch Tel: +49 (0) 69 9508 6208
 English Tel: +44 (0) 870 24 0 2171
 Français Tel: +33 (0) 1 41 91 8790

National Semiconductor
Asia Pacific Customer
Support Center
 Email: ap.support@nsc.com

National Semiconductor
Japan Customer Support Center
 Fax: 81-3-5639-7507
 Email: jpn.feedback@nsc.com
 Tel: 81-3-5639-7560

D-Sub Connectors

Right Angle Female



Dimensional Drawing Pressfit (Clip), Assembly Height 3.6 mm

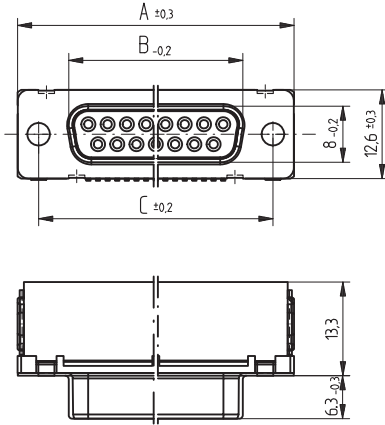

9	31.0	16.4	25.0	10.96	8.22	2.74	1.37
15	39.3	24.75	33.3	19.18	16.44	2.74	1.37
25	53.0	38.5	47.0	33.12	30.36	2.76	1.38
37	69.5	54.95	63.5	49.68	46.92	2.76	1.38
Pohlzahl No. of contacts	A	B	C	D	E	F	G

Metal plating of plated-through hole see drawing 164062
No. 6 + 12

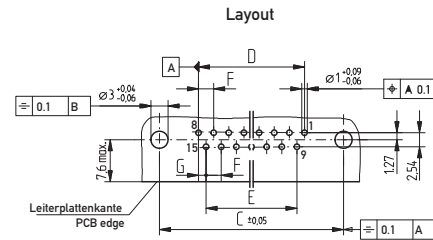
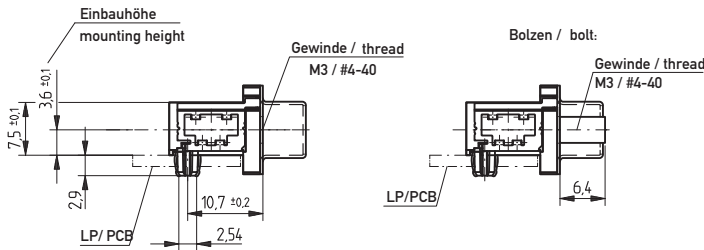

Dimensional Drawing Pressfit (Screw), Assembly Height 7.3 mm

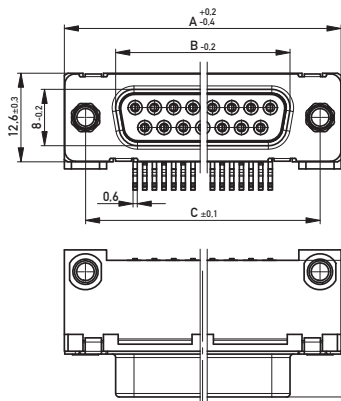

9	31.00	16.40	25.00	10.96	8.22	2.74	1.37
15	39.30	24.75	33.30	19.18	16.44	2.74	1.37
25	53.00	38.50	47.00	33.12	30.36	2.76	1.38
37	69.50	54.95	63.50	49.68	46.92	2.76	1.38
Pohlzahl No. of contacts	A	B	C	D	E	F	G

Metal plating of plated-through hole see drawing 164062
No. 6 + 12

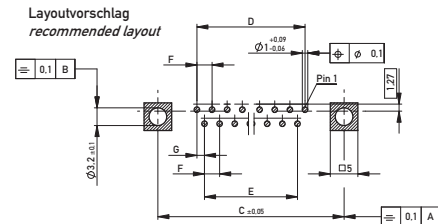
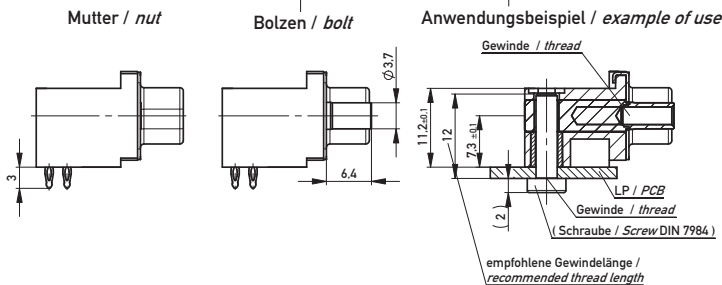

All dimensions in mm

Features

- ◆ Compact metal case with screw terminal block
- ◆ Dual and triple output models with isolated outputs
- ◆ Universal input 85–264 VAC
- ◆ EMI/EMC compliance with EN 61000-6-3 and EN 61000-6-1
- ◆ Compliance to EN 61000-3-2 (PFC)
- ◆ Short circuit and overvoltage protection
- ◆ International safety approvals
- ◆ 3-year product warranty

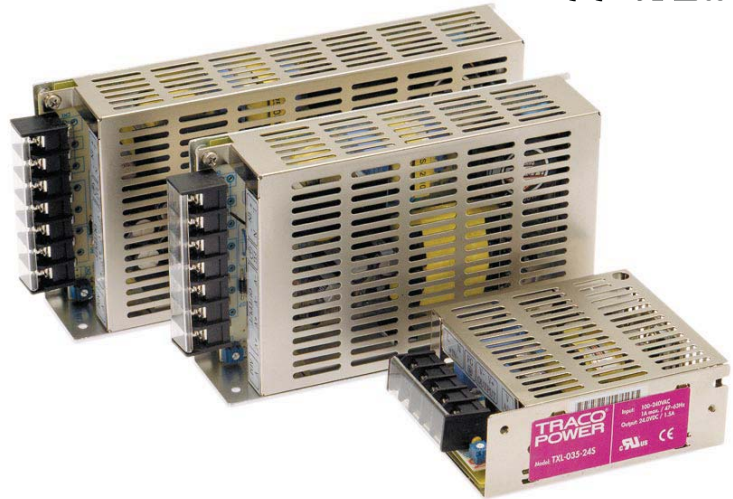

The TRACOPOWER TXL series is a family of enclosed power supplies designed for a wide range of cost critical applications. With a low profile metal case and screw terminal block connection, they are easy to install in any equipment.

There are 59 models in this range with single, dual, and triple output voltages from 3.3 VDC to 48 VDC in 10 power ranges from 25 W to 1000 W. These power supplies have universal input and comply with European EMC standards and the Low Voltage Directive (LVD).

Models with Single Output				
Order Code	Case Type	Output Power max.	Output Voltage nom.	Output Current max.
TXL 025-3.3S	C	25 Watt	3.3 VDC	6.0 A
TXL 025-05S			5 VDC	5.0 A
TXL 025-12S			12 VDC	2.1 A
TXL 025-15S			15 VDC	1.7 A
TXL 025-24S			24 VDC	1.1 A
TXL 025-48S			48 VDC	0.57 A
TXL 035-3.3S	D	35 Watt	3.3 VDC	9.0 A
TXL 035-05S			5 VDC	7.0 A
TXL 035-12S			12 VDC	3.0 A
TXL 035-15S			15 VDC	2.4 A
TXL 035-24S			24 VDC	1.5 A
TXL 035-48S			48 VDC	0.75 A
TXL 050-05S	E	50 / 60 Watt	5 VDC	10.0 A
TXL 060-12S			12 VDC	5.0 A
TXL 060-15S			15 VDC	4.0 A
TXL 060-24S			24 VDC	2.5 A
TXL 060-3.3S	E	60 / 70 Watt	3.3 VDC	15.0 A
TXL 060-05S			5 VDC	12.0 A
TXL 070-12S			12 VDC	6.0 A
TXL 070-15S			15 VDC	4.8 A
TXL 070-24S			24 VDC	3.0 A
TXL 070-48S			48 VDC	1.5 A

Models with Single Output

Order Code	Case Type	Output Power max.	Output Voltage nom.	Output Current max.
TXL 100-3.3S TXL 100-05S TXL 100-12S TXL 100-15S TXL 100-24S TXL 100-48S	J	100 Watt	3.3 VDC 5 VDC 12 VDC 15 VDC 24 VDC 48 VDC	25.0 A 20.0 A 8.5 A 6.8 A 4.5 A 2.1 A
TXL 120-12S TXL 120-15S TXL 120-24S TXL 120-48S	K	120 Watt	12 VDC 15 VDC 24 VDC 48 VDC	10.0 A 8.0 A 5.0 A 2.5 A
TXL 150-05S TXL 150-12S TXL 150-24S TXL 150-48S	L	150 Watt	5 VDC 12 VDC 24 VDC 48 VDC	30.0 A 12.5 A 6.3 A 3.2 A
TXL 220-12S TXL 220-24S TXL 220-48S	N	220 Watt	12 VDC 24 VDC 48 VDC	18.4 A 9.2 A 4.6 A
TXL 300-24S TXL 300-48S	O	300 Watt	24 VDC 48 VDC	12.5 A 6.5 A
TXL 600-24S TXL 600-48S	P	600 Watt	24 VDC 48 VDC	25.0 A 12.5 A
NEW TXL 1000-24S* TXL 1000-48S*	Q	1000 Watt	24 VDC 48 VDC	40.0 A 20.0 A

* Specifications to be advised

Models with Multiple Output

Order Code	Case Type	Output Power max.	* Output 1 (Main Output)	* Output 2	* Output 3
TXL 035-0512D TXL 035-0524D TXL 035-1212D TXL 035-1515D	D	35 Watt	+5 VDC/ 4.0 A +5 VDC/ 4.0 A +12 VDC/ 1.5 A +15 VDC/ 1.3 A	+12 VDC/ 1.5 A +24 VDC/ 1.3 A -12 VDC/ 1.5 A -15 VDC/ 1.3 A	
TXL 060-0512DI TXL 060-0524DI TXL 060-0521TI TXL 060-0522TI TXL 060-0533TI TXL 060-0534TI	E	60 Watt	+5 VDC/ 8.0 A +5 VDC/ 6.0 A +5 VDC/ 8.0 A +5 VDC/ 7.0 A +5 VDC/ 7.0 A +5 VDC/ 6.0 A	+12 VDC/ 4.0 A +24 VDC/ 2.2 A +12 VDC/ 3.5 A +12 VDC/ 3.5 A +15 VDC/ 3.0 A +12 VDC/ 1.5 A	-5 VDC/ 1.0 A -12 VDC/ 1.0 A -15 VDC/ 1.0 A +24 VDC/ 1.2 A
TXL 100-0512DI TXL 100-0524DI TXL 100-0521TI TXL 100-0522TI TXL 100-0533TI TXL 100-0534TI	J	100 Watt	+5 VDC/ 12.0 A +5 VDC/ 10.0 A +5 VDC/ 12.0 A +5 VDC/ 12.0 A +5 VDC/ 12.0 A +5 VDC/ 12.0 A	+12 VDC/ 6.0 A +24 VDC/ 4.0 A +12 VDC/ 5.0 A +12 VDC/ 5.0 A +15 VDC/ 3.0 A +12 VDC/ 3.0 A	-5 VDC/ 1.5 A -12 VDC/ 1.5 A -15 VDC/ 1.5 A +24 VDC/ 2.0 A

* Total power must not exceed specified max. output power

Input Specifications

Input voltage range		85–264 VAC	
		88–264 VAC (TXL 100 & TXL 300 models)	
Input frequency		47–63 Hz	
Input current (at full load)		$V_{in} = 115 \text{ VAC}$	$V_{in} = 230 \text{ VAC}$
	TXL 025 models	0.54 A typ.	0.22 A typ.
	TXL 035 models	0.70 A typ.	0.42 A typ.
	TXL 060/ 070 models	1.00 A typ.	0.60 A typ.
	TXL 100 models	1.65 A typ.	0.95 A typ.
	TXL 120 models	1.30 A typ.	0.65 A typ.
	TXL 150 models	2.10 A typ.	1.10 A typ.
	TXL 220 models	3.00 A typ.	1.60 A typ.
	TXL 300 models	3.30 A typ.	1.70 A typ.
	TXL 600 models	6.30 A typ.	3.10 A typ.
Input current (at no load)		$V_{in} = 115 \text{ VAC}$	$V_{in} = 230 \text{ VAC}$
	TXL 025 models	10 mA typ.	17 mA typ.
	TXL 035 models	50 mA typ.	55 mA typ.
	TXL 120 models	135 mA typ.	125 mA typ.
	TXL 220/300 models	115 mA typ.	140 mA typ.
	TXL 600 models	210 mA typ.	220 mA typ.
	other models	100 mA typ.	80 mA typ.
Recommended circuit breaker (characteristic C) or slow blow fuse	TXL 025/035/060/070 models	5 A	
	TXL 100/120/150/220 models	10 A	
	TXL 300 models	15 A	
	TXL 600 models	20 A	

Output Specifications

Output voltage adjustment range		$\pm 10 \%$
		– 35 Watt dual output models: range V_{out} 1-2
		– other multi output models: V_{out} 1
Regulation	– Input variation	1 % max.
	– Load variation (10–100%)	single output models: 2 % max.
		multiple output models: 4 % max. for main output
		6 % max. for output 2/3 (20–100 % load)
	– Minimum load on main output of multiple output models (to provide the regulation on the auxiliary outputs)	0.3 A for TXL 035 1.0 A for TXL 060 1.5 A for TXL 100
Ripple and noise (20 MHz bandwidth)	3.3VDC output	< 50mV
	Output 3 (on triple output models)	< 1.5% of V_{out}
	all other output voltages	< 1.0% of V_{out} nom.
Output current limitation		105 %–150 % of I_{out} max.
Overload protection mode		Fold back, automatic recovery
Over voltage protection (only output 1)		115 %–140 % of V_{out} nom. (depending on model)
Capacitive load, max.	3.3 VDC–12 VDC output models	10'000 μF
	TXL 070: 24 VDC & 48VDC output models	10'000 μF
	TXL 100/150: 24 VDC & 48VDC output models	4'700 μF
	TXL 035/ 120: 24 VDC & 48VDC output models	1'000 μF
	TXL 025/ TXL 220: models	5'000 μF
	TXL 300 models	17'000 μF
	TXL 600 models	44'000 μF

General Specifications

Temperature ranges	– Operating – Load derating above 45°C – Storage (non operating)	– 10 °C to +70 °C 2% /°K (2.5%/°K for TXL 120/220) – 10 °C to +75 °C
Temperature coefficient		0.02 %/°C
Efficiency		70–84 % (depending on model)
Humidity (non condensing)		85 % rel max. (non condensing)
Switching frequency		50 kHz typ. (pulse width modulation)
Hold-up time		20 ms min.
Isolation voltage (60sec)	– Input/Output – Input/Case – Output/Case – Output/Output	3'000 VAC 1'500 VAC 500 VAC
	60-100 Watt multiple output models: 35 Watt dual output models:	500 VAC (for all outputs of triple output models!) outputs not isolated
Reliability /calculated MTBF (MIL-HDBK-217F)		>250'000 h @ 25 °C typ.
Electromagnetic compatibility (EMC), Emissions	– Conducted input RI suppression – Harmonic current emissions – Flicker	EN 55022, class B, FCC part 15, level B IEC/EN 61000-3-2, class D (TXL 120/150/220) IEC/EN 61000-3-2, class A (others) IEC/EN 61000-3-3
Electromagnetic compatibility (EMC), Immunity	– Electrostatic discharge ESD – RF field immunity – Electrical fast transients/burst immunity – Surge – Conducted RF – Magnetic field – Voltage dip	IEC/EN 61000-4-2 4 kV / 8 kV IEC/EN 61000-4-3 3 V/m IEC/EN 61000-4-4 1 kV IEC/EN 61000-4-5 1 kV / 2 kV IEC/EN 61000-4-6 3 V/m IEC/EN 61000-4-8 3 A/m IEC/EN 61000-4-11
Safety standards		UL 60950-1, IEC 60950-1, EN 60950-1
Safety approval		cUL/UL File E188913
Case material	TXL 025/035 TXL 50/60/70/100 others	nickel plated steel (chassis & cover) aluminium (chassis), nickel plated steel (cover) aluminium (chassis & cover)

All specifications valid at nominal input voltage, full load and +25°C after warm-up time unless otherwise stated.

Case Dimensions

Case K

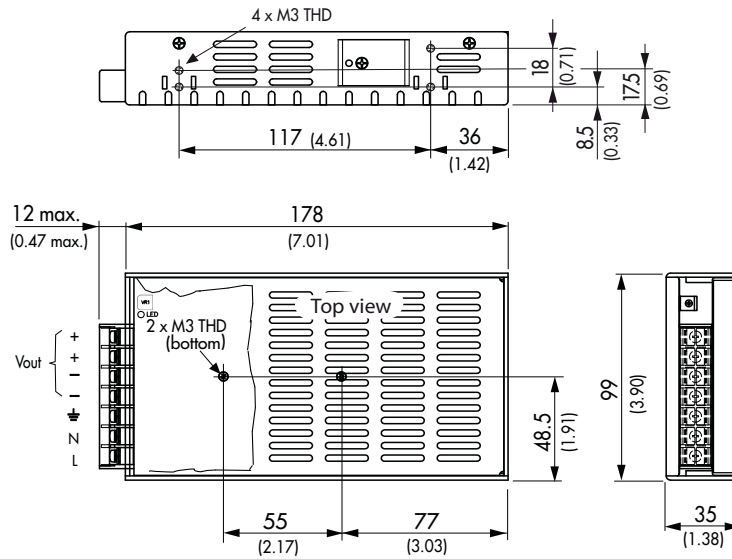

Weight: 0.82 kg (29 oz)

Case L

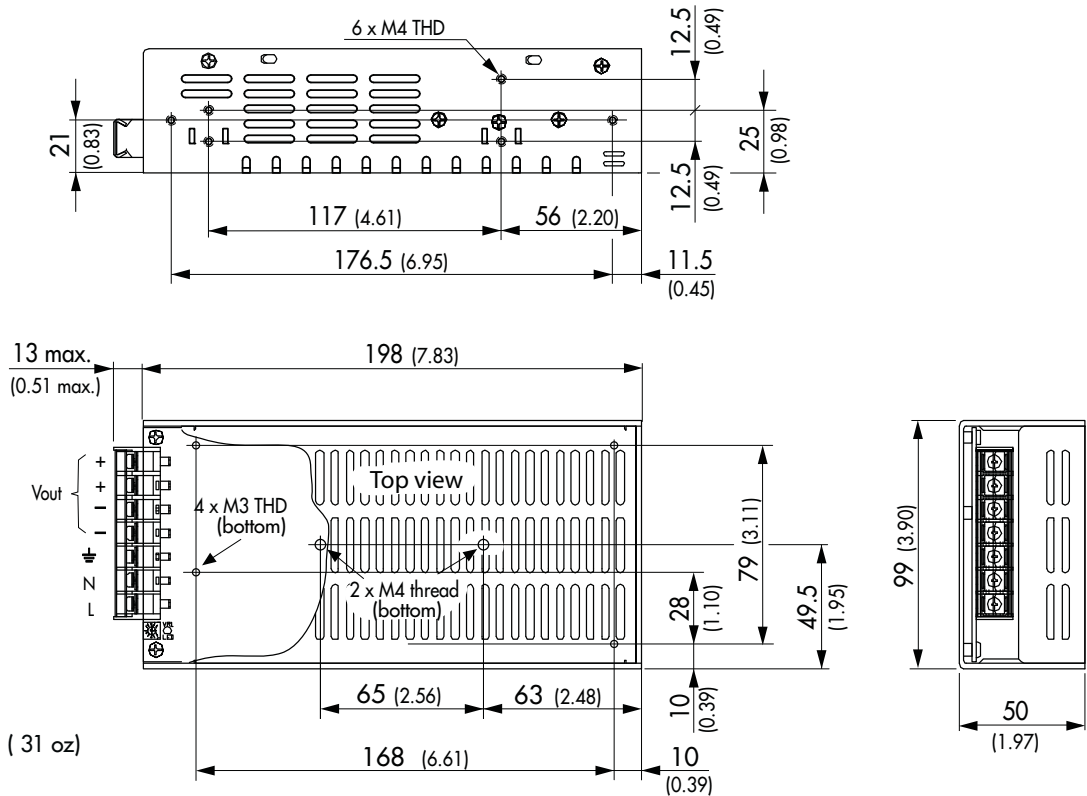

Weight: 0.89 kg (31 oz)

Tolerances and max. screw penetration see page 9

SPECIFICATION

Feature: light option and inrush current capability
 Rating: 5A 250VAC, 10A 125VAC (UL)
 7A 250VAC, 10A 125VAC (CSA);
 6A 250VAC~µT85 (D, S, N, FI, VDE)
 Inrush Current: 50A peak at 250VAC for 4ms
 Contact Resistance: 20 milliohms max. @ initial
 Insulation Resistance: 500 megaohms min. @ 500VDC
 Dielectric Strength: 2,000VAC for 1 minute
 Life Cycle: 10,000
 Operating Force: 500-800g
 Safety Standard Approval: CSA, DEMKO, FIMKO, NEMKO, SEMKO, UL, VDE
 RoHS Compliant: yes

MATERIAL

Actuator: nylon 66
 Housing: nylon 66
 Contact: silver plated copper alloy
 Moving Contact: silver plated phosphor bronze
 Center Terminal: tin plated copper
 Stationary Contact Terminal: tin plated copper
 Lamp: 110 or 220VAC neon; 12VDC incandescent

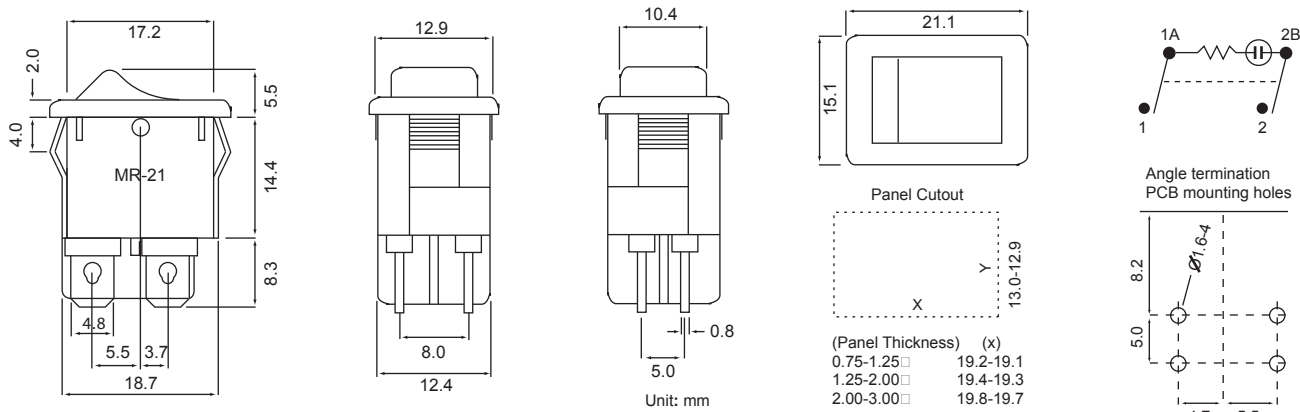

PART NUMBERING FORMAT

MR - 21 [Function] - [Label] [Housing Color] [Actuator Color] - [Terminal] [Housing] [Light] Ex: MR-21L-2BV-F2A

Function	Label	Housing Color	Actuator Color	Light (resistor value)
M: on-off (no light, SP)	1: none	B: black	B: black	None: No light
N: on-off (no light, DP)	2: - o	W: white	W: white	E: neon (47K)
C: on-off (light, SP)	3: l o	H: grey	H: grey	C: neon (100K)
L: on-off (light, DP)	4: o	M: misty grey	M: misty grey	A: neon (120K)
	B: -	L: light grey	L: light grey	B: neon (150K)
	8: ON OFF	K: slate grey	K: slate grey	D: incandescent-12VDC
		N: carbon grey	N: carbon grey	
		F: buff	F: buff	
		P: light purple	P: light purple	
		D: dark red	D: dark red	
		Z: light ivory	Z: light ivory	
			X: purple	
			R: red	
			J: amber (light)	
			V: red (light)	
			U: green (light)	
			E: ivory (light)	

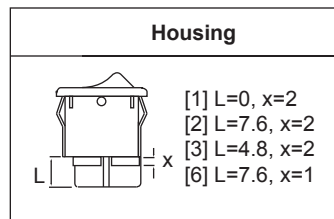
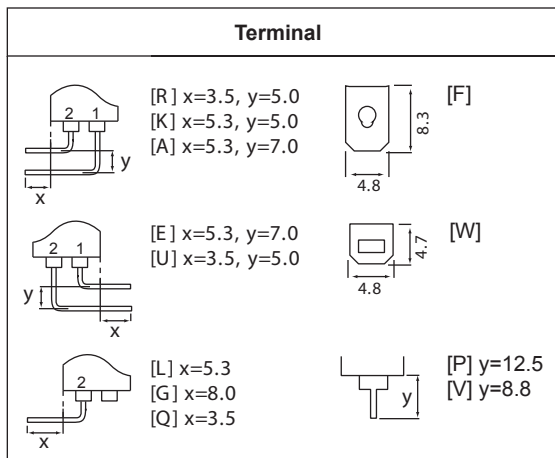

SDPSI**Antivibration Flexible Couplings – Compact**

Stock Drive Products/Sterling Instrument ■ Phone: 516-328-3300 ■ Fax: 516-326-8827

■ ABSORBS VIBRATION

■ EXCELLENT ELECTRICAL INSULATION

■ ZERO BACKLASH

■ HIGH RESPONSE

■ HIGH TORQUE

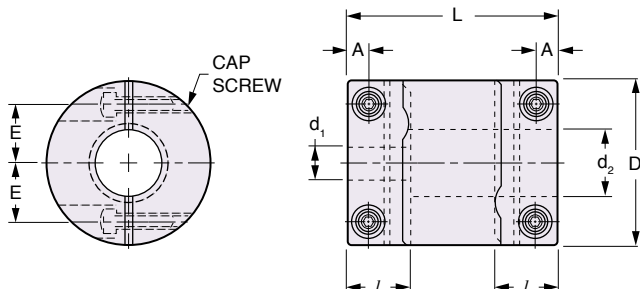

Continued on the next page

The projections shown are per ISO convention.

MISALIGNMENT COMPENSATION

Max. Angular Offset – 1.5°

Max. Lateral Offset – 0.15

Max. Axial Motion – ±0.2

MATERIAL: Hubs – Aluminum

Center – Molded Rubber

Cap Screws – Steel, Black Oxide

OPERATING TEMPERATURE: -20°C to +80°C**APPLICATIONS:**

Outstanding performance when used with servomotors or stepping motors for the following reasons:

- Eliminates Resonance
- Absorbs Vibration
- High Speed & Precise Positioning
- Increases Gain

Catalog Number	D	d ₁ * Bore	d ₂ * Bore	L	l	A	E	Cap Screw	Max. Bore
S50XGSMA15H0305	15	3	5	18	6.5	2.15	5	M1.6	6
S50XGSMA15H0404		4	4						
S50XGSMA15H0406		4	6						
S50XGSMA19H0606	19	6	6	20	7.7	2.65	6.5	M2	8
S50XGSMA19H06E6		6	6.35						
S50XGSMA19H0608		6	8						
S50XGSMA19H08E6		6.35	8						
S50XGSMA25H08E6	25	6.35	8	27	9.5	3.25	9	M2.5	12
S50XGSMA25H0808		8	8						
S50XGSMA25H0810		8	10						
S50XGSMA25H0811		8	11						

*Shaft Tolerance (h7): 3 to 6 mm -0.012
 6.35 & 10 mm -0.015
 11 mm -0.018

SPECIFICATIONS

Coupling Series (Ref. only)	Rated Torque N·m	Max. rpm	Moment of Inertia ^Δ kg·m ²	Static Torsional Stiffness N·m/rad	Weight ^Δ grams
S50XGSMA15H...	0.5	42000	2 × 10 ⁻⁷	25	7
S50XGSMA19H...	0.8	33000	6.2 × 10 ⁻⁷	63	12
S50XGSMA25H...	2.3	25000	2.3 × 10 ⁻⁶	125	25

^ΔBased on max. bore dimension.

■ ABSORBS VIBRATION

■ EXCELLENT ELECTRICAL INSULATION

■ ZERO BACKLASH

■ HIGH RESPONSE

■ HIGH TORQUE

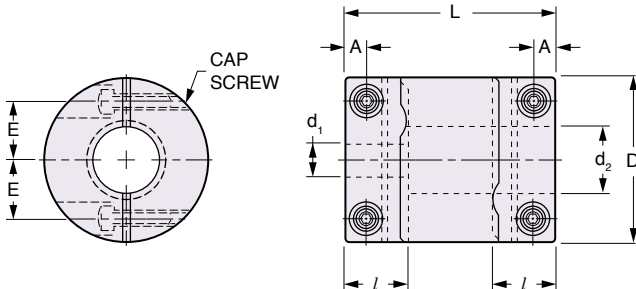

Continued from the previous page

The projections shown are per ISO convention.

MISALIGNMENT COMPENSATION

Max. Angular Offset – 1.5°

Max. Lateral Offset – 0.2

Max. Axial Motion – ±0.3

MATERIAL: Hubs – Aluminum

Center – Molded Rubber

Cap Screws – Steel, Black Oxide

OPERATING TEMPERATURE: -20°C to +80°C**APPLICATIONS:**

Outstanding performance when used with servomotors or stepping motors for the following reasons:

- Eliminates Resonance
- Absorbs Vibration
- High Speed & Precise Positioning
- Increases Gain

Catalog Number	D	d ₁ * Bore	d ₂ * Bore	L	l	A	E	Cap Screw	Max. Bore
S50XGMA30H0812	30	8	12	30	11	4	11	M3	15
S50XGMA30H1010		10	10						
S50XGMA30H1212		12	12						
S50XGMA34H1012	34	10	12	35	12	4	12.25	M3	16
S50XGMA34H1111		11	11						
S50XGMA39H1212	39	12	12	40	15.5	4.5	14.5	M4	20
S50XGMA39H1216		12	16						

*Shaft Tolerance (h7): 8 & 10 mm -0.015
11 to 16 mm -0.018

SPECIFICATIONS

Coupling Series (Ref. only)	Rated Torque N·m	Max. rpm	Moment of Inertia ^Δ kg·m ²	Static Torsional Stiffness N·m/rad	Weight ^Δ grams
S50XGMA30H...	3.3	21000	5.5 x 10 ⁻⁶	160	39
S50XGMA34H...	5.5	18000	1 x 10 ⁻⁵	350	62
S50XGMA39H...	7	16000	2.1 x 10 ⁻⁵	440	85

^ΔBased on max. bore dimension.

MagLev Motor AC Fan

40 / 41 CFM



Model	P/N	Bearing ● VAPO ⊙ 2BALL	Rating Voltage (VAC)	Freq. (Hz)	Power Current (AMP)	Power Consumption (WATTS)	Speed (RPM)	Air Flow (CFM)	Static Pressure (Inch-HzO)	Noise (dBA)	Weight (g)
MA1082-HVL	GN	●	115	50/60	0.112/0.116	3.6/3.6	3200/3300	40/41	0.14/0.15	32/33	102.2
MA2082-HVL	GN	●	230	50/60	0.102/0.101	4.6/4.6	3200/3300	40/41	0.14/0.15	32/33	102.2

Frame : PBT Plastic

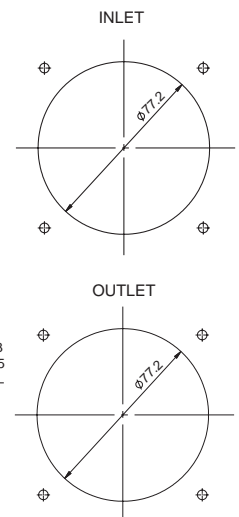
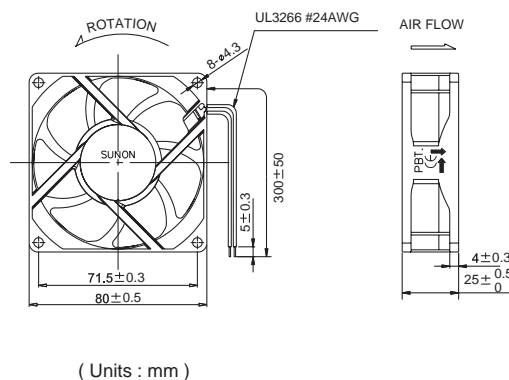
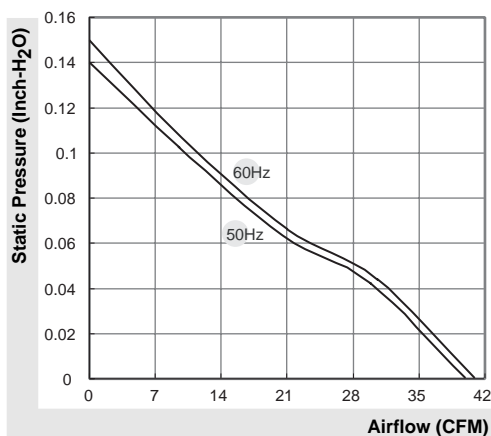

*The rated current is TRUE RMS current measured by BASE-450 (Autoranging Digital V-A-W METER).

*All model could be customized on voltage or any other requirements to fit your need.

*Specifications subject to change without notice. Please Visit SUNON web site at <http://www.sunon.com> for update information.

BULGIN Power Inlets and Outlets



IEC 320-1 FUSED POWER INLETS

5x20MM Single Fuse 10A 250VAC

• Room for spare fuse

• Fuses sold Separately



RoHS Compliant

For quantities of 250 and up, call for quote.

MOUSER STOCK NO.	Bulgin Part No.	Fig.	Description	Price Each			
				1	25	50	100
161-PF0001/28	PF0001/28	A	Chassis mount 2.8mm solder tab				
161-PF0001/63	PF0001/63	A	Chassis mount 6.3mm faston tab				
161-PF0011/10/28	PF0011/10/28	B	Snap-in fit, 2.8mm solder tabs, 1mm panel thickness				
161-PF0011/15/28	PF0011/15/28	B	Snap-in fit, 2.8mm solder tabs, 1.5mm panel thickness				
161-PF0011/10/63	PF0011/10/63	B	Snap-in fit, 6.3mm faston tabs, 1mm panel thickness				
161-PF0011/15/63	PF0011/15/63	B	Snap-in fit, 6.3mm faston tabs, 1.5mm panel thickness				

Twin Fused 10A 250VAC

For quantities of 250 and up, call for quote.

MOUSER STOCK NO.	Bulgin Part No.	Fig.	Description	Price Each			
				1	25	50	100
161-PF0030/28	PF0030/28	C	Chassis mount, 2.8mm solder tabs				
161-PF0030/63	PF0030/63	C	Chassis mount, 6.3mm faston tabs				
161-PF0033/15/28	PF0033/15/28	D	Snap-in fit, 2.8mm solder tabs, 1.5mm panel thickness				
161-PF0033/15/63	PF0033/15/63	D	Snap-in fit, 6.3mm faston tabs, 1.5mm panel thickness				

IEC 320-1 POWER INLETS

15A, 250VAC, UL and CSA



RoHS Compliant

For quantities of 250 and up, call for quote.

MOUSER STOCK NO.	Bulgin Part No.	Fig.	Description	Price Each			
				1	25	50	100
161-PX0575/10/28	PX0575/10/28	E	Snap-in fit, 2.8mm solder tabs, 1mm panel thickness				
161-PX0575/15/28	PX0575/15/28	E	Snap-in fit, 2.8mm solder tabs, 1.5mm panel thickness				
161-PX0575/10/63	PX0575/10/63	E	Snap-in fit, 6.3mm faston tabs, 1mm panel thickness				
161-PX0575/15/63	PX0575/15/63	E	Snap-in fit, 6.3mm faston tabs, 1.5mm panel thickness				
161-PX0580/28	PX0580/28	F	Chassis mount, 2.8mm solder tabs				
161-PX0580/63	PX0580/63	F	Chassis mount, 6.3mm faston tabs				
161-PX0580/PC	PX0580/PC	G	PC mount				

IEC 320-1 C20 POWER INLETS

20A, 250VAC, UL and CSA



RoHS Compliant

For quantities of 250 and up, call for quote.

MOUSER STOCK NO.	Bulgin Part No.	Fig.	Description	Price Each			
				1	25	50	100
161-PX0596/63	PX0596/63	H	C20 Chassis mount, 6.3mm faston				
161-PX0598/15/63	PX0598/15/63	I	C20 Snap-in fit, 6.3mm faston, 1.5mm panel thickness				

IEC 320-2-2 POWER OUTLETS

15A, 250VAC, UL and CSA



RoHS Compliant

For quantities of 250 and up, call for quote.

MOUSER STOCK NO.	Bulgin Part No.	Fig.	Description	Price Each			
				1	25	50	100
161-PX0675/28	PX0675/28	J	Chassis mount, 2.8mm solder tabs				
161-PX0675/63	PX0675/63	J	Chassis mount, 6.3mm faston tabs				
161-PX0675/PC	PX0675/PC	K	PC mount				
161-PX0675/PC/12599	PC0675/PC/12600	K	PC mount with rear cover				

IEC 320-2-2 POWER OUTLETS

15A, 250VAC, UL and CSA



RoHS Compliant

For quantities of 250 and up, call for quote.

MOUSER STOCK NO.	Bulgin Part No.	Fig.	Description	Price Each			
				1	25	50	100
161-PX0695/15/28	PX0695/15/28	L	Snap-in fit, 2.8mm solder tabs, 1.5mm panel thickness				
161-PX0695/15/63	PX0695/15/63	L	Snap-in fit, 6.3mm faston tabs, 1.5mm panel thickness				

C14 IEC 320-1 FUSED INLETS

• Fuses sold Separately



RoHS Compliant

For quantities of 250 and up, call for quote.

MOUSER STOCK NO.	Bulgin Part No.	Fig.	Description	Price Each			
				1	25	50	100
161-BZV01/Z0000/01	BZV01/Z0000/01	M	Snap-in fit, SP switch, 6.3mm faston tabs				
161-BZV01/Z0000/02	BZV01/Z0000/02	M	Snap-in fit, SP red neon switch, 6.3mm faston tabs				
161-BZV01/Z0000/10	BZV01/Z0000/10	M	Snap-in fit, DP switch, 6.3mm faston tabs				
161-BZV01/Z0000/11	BZV01/Z0000/11	M	Snap-in fit, DP red neon switch, 6.3mm faston tabs				

Retaining Clip Kit



RoHS Compliant

For quantities of 250 and up, call for quote.

MOUSER STOCK NO.	Bulgin Part No.	Fig.	Description	Price Each			
				1	25	50	100
161-KT0006	KT0006	N	Fits Bulgin PX0580, PX0590, PX0675, PX0690, PX0793, & PX0739/1				
161-KT0012	KT0012	N	Fits Bulgin PX0596				

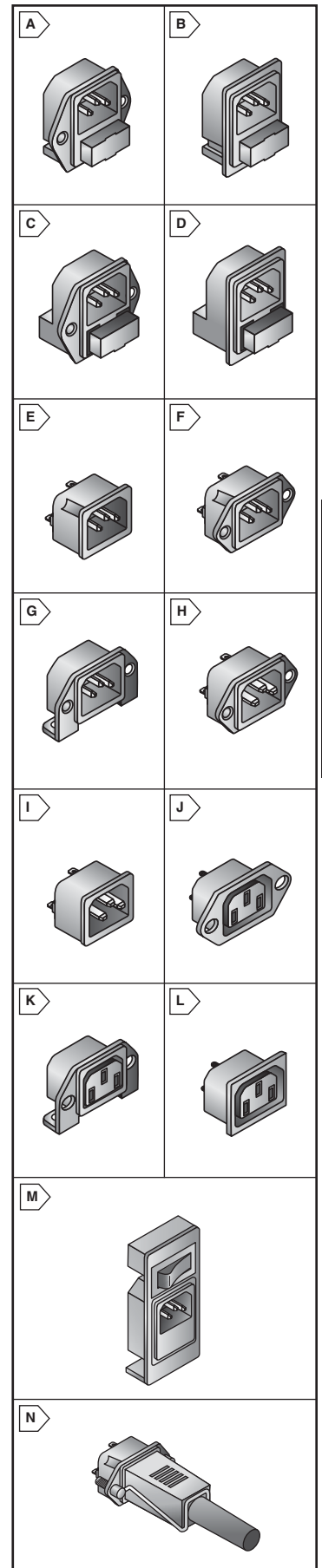

AC Power Connectors
Bulgin